

QUICK REFERENCE HAND BOOK

A319/A320/A321

QATAR AIRWAYS القطرية 

 **AIRBUS**[®]

IMPORTANT**SCOPE**

The QRH contains some specific procedures which are not displayed on the ECAM.

As a general rule, the procedures displayed on the ECAM are not provided in the QRH (refer to FCOM 3.02).

TASKSHARING FOR ABN/EMER PROC

For all abnormal/emergency procedures, the tasksharing is as follows :

- R PF – Pilot flying – Responsible for the :
- Thrust levers
 - Flight path and airspeed control
 - Aircraft configuration (request configuration change)
 - Navigation
 - Communications
- R PNF – Pilot non flying – Responsible for the :
- Monitoring and reading aloud the ECAM and checklists
 - Performing required actions or actions requested by the PF, if applicable
 - Using engine master switches, IR and guarded switches with PF's confirmation.
- R
- R
- R
- R
- R

ECAM CLEAR

DO NOT CLEAR ECAM WITHOUT CROSS-CONFIRMATION OF BOTH PILOTS.

ABN/EMER PROC INITIATION

Procedures are initiated on pilot flying command.

No action will be taken (apart from audio warning cancel through MASTER WARN light) until :

- The appropriate flight path is established, and
- The aircraft is at least 400 feet above the runway, if a failure occurs during takeoff, approach, or go-around. (In some emergency cases, provided the appropriate flight path is established, the pilot flying may initiate actions before this height).

NORMAL CHECKLIST

Normal C/L are initiated by the PF and read by the PNF.

The PF shall respond after having checked the existing configuration. When both pilots have to respond, "BOTH" is indicated.

USE OF SUMMARIES**GENERAL**

In case of an electrical emergency configuration, or a dual hydraulic failure :

The ECAM should be applied first.

This includes both the procedure, and the STATUS section.

Only after announcing "ECAM ACTIONS COMPLETED", should the PNF refer to the corresponding QRH summary.

When the failure occurs, and after performing the ECAM actions, the PNF should refer to the "CRUISE" portion of the summary, in order to determine the landing distance coefficient.

Since normal landing distances are also given on this page, the PNF will be able to compute the landing distance taking failure(s) into account, in order for the pilot to decide whether to divert or not.

APPROACH PREPARATION

As always, approach preparation includes a review of the ECAM STATUS.

After reviewing the STATUS, the PNF should refer to the "CRUISE" portion of the summary, to determine the VREF correction, and **compute the VAPP**.

A VREF table is provided in the summary, for failure cases leading to the loss of the MCDU.

The LANDING and GO-AROUND portions of the summary should be used for the **approach briefing**.

APPROACH

The APPR PROC actions should be performed by reading the APPROACH portion of the summary.

The PNF should then review the ECAM STATUS, and check that all the APPR PROC actions have been completed.

CODE	DESIGNATION
0002	Mod : 20268 = (20268+25800)
0005	Mod : (20268+28342) = (20268+28342+31106)
0006	Mod : (20268+24946+26965) = (20268+24946+27773) = (20268+25951+26965) = (20268+25951+27773) = (20268+26760+26965) = (20268+26760+27773) = (20268+26965+32150) = (20268+26965+32238) = (20268+26965+32239) = (20268+26965+32311) = (20268+27773+32150) = (20268+27773+32238) = (20268+27773+32239) = (20268+27773+32311) = (20268+31106+32238) = (20139+20268+22129+24946+27773+31106)
0007	Mod: (20268+25647+26965) = (20268+25647+31106) = (ACA + 20268+25647+31106)
R 0008	Mod : (20059+20343) = (20059+31276) = (31276+35236) = (20059+20343+31276)
0014	Mod: (20268) = (20268+20139+22129)
0015	Mod : (24105+24215+24588+24794+28238) = (24105+24215+24588+24794+28238+32090)
0016	Mod : (20268 + 28342) = (20268 + 28342 + 27773)
0019	Mod : 20268 = (20268+25800)
0020	Mod : (20268+25530) = (20268+25530+25800) = (20268+25800+27727) = (20268+25530+25800+27727)
0021	Mod : (20268+24404) = (20268+24404+25800) = (20268+25800+27727) = (20268+24404+25800+27727)
0022	Mod : 20268 = (20268+25800) = (20268+24404+25502) = (20268+24404+25502+25800)
0023	Mod : (20268+24405) = (20268+24405+25800) = (20268+25800+27727) = (20268+24405+25800+27727)
0024	Mod : 20268 = (20268+25800) = (20268+24405+25501) = (20268+24405+25501+25800)
0025	Mod: (20268+25647+26965) = (20268+25647+31106) = (20268+25647+31106+32311)
0027	Mod: 20268 = (20268+21678+25404+26965) = (20268+21678+25404+31106)
0029	Mod : 20268 = (20268+25647+ACA)
0031	Mod: (20268+21678) = (20268+21678+20139+22129)
0032	Mod: (20268+24946+26965) = (20268+24946+27773) = (20268+25951+26965) = (20268+25951+27773) = (20268+26760+26965) = (20268+26760+27773) = (20268+26965+32150) = (20268+26965+32238) = (20268+26965+32239) = (20268+26965+32311) = (20268+27773+32150) = (20268+27773+32238) = (20268+27773+32239) = (20268+27773+32311) = (20268+24946+31106)
0033	Mod : (20268+21678+24946+27773) = (20268+21678+27773+32238) = (20268+21678+25951+31106) = (20268+21678+31106+32311) = (20268+21678+24946+31106)
0034	Mod: (20268+21678+24946+26965) = (20268+21678+24946+27773) = (20268+21678+25951+26965) = (20268+21678+25951+27773) = (20268+21678+26760+26965) = (20268+21678+26760+27773) = (20268+21678+26965+32150) = (20268+21678+26965+32238) = (20268+21678+26965+32239) = (20268+21678+26965+32311) = (20268+21678+27773+32150) = (20268+21678+27773+32238) = (20268+21678+27773+32239) = (20268+21678+27773+32311) = (20268+21678+31106+32238) = (20139+20268+21678+22129+24946+27773+31106)
0035	Mod : (20268+28238) = (20268+25800+28238)
0036	Mod : 20268 = (20268+25225+28399)+IAE V2500 = V2527 = V2527E

CODE	DESIGNATION
0038	Mod : (20268+21678+24946+25404+27773) = (20268+21678+24946+25404+31106) = (20268+21678+25404+25951+31106) = (20268+21678+25404+31106+32311) = (20268+21678+25404+31106+32238) = (20268+21678+24946+25404+27773+28160+28917)
R 0040	Mod : (20063+22562+31495) = (20063+31495+35864) = (20063+22562+31495+35864)
R 0041	Mod : (20151+22562+31495) = (22562+23092+31495) = (22562+31112+31495) = (20063+20151+22562+31495) = (20063+22562+31112+31495) = (20063+20151+31495+35864) = (20063+31112+31495+35864) = (20063+22562+31112+31495+35864) = (20063+20151+31495+22562+35864)
0042	Mod : (20268+21678+25404+26760+27773) = (20268+21678+24946+25404+27773) = (20268+21678+25404+31106+32238) = (20268+21678+25404+31106+32239) = (20268+21678+25404+31106+32311) = (20268+21678+24946+25404+27773+28160+28917)
0045	Mod : 20268+21678+24946+25404+27773 = (20268+21678+25404+31106+32239) = (20268+21678+25404+31106+32311) = (20268+21678+25404+28160+28917+31106+32311)
R 0046	Mod : (20151+22013+22562+31495) = (22013+22562+23092+31495) = (22013+22562+31112+31495) = (20063+20151+22013+22562+31495) = (20063+20151+22013+31495+35864) = (20063+20151+22013+22562+31495+35864) = (20063+20151+22013+31112+31495+35864)
0047	Mod : (20268+21678+24946+25404+27773+28160) = (20268+21678+25404+28160+31106+32239) = (20268+21678+25404+28160+31106+32311) = (20268+21678+24946+25404+26965+27773+28160) = (20268+21678+25404+26965+27773+28160+32311)
R 0050	Mod : (34637+35353) = (26526+34637+35353)
0057	Mod : 20268 = (20268+25225+28399)
0059	Mod : (32090+35218) = (28160+28917+32090+35218)
0060	Mod : (25534+32090+35218) = (24215+24588+32090+35218) = (24215+24588+25534+32090+35218) = (24215+24588+28160+28917+32090+35218)
0061	Mod : (22013+24215+24588+32090+35218) = (22013+24215+24588+32090+35219) = (24105+24215+24588+32090+35218) = (24105+24215+24588+32090+35219) = (24215+24588+28160+32090+35218) = (24215+24588+28160+32090+35219)
0064	Mod : (24105+25529+30020) = (24105+26270+30020) = (24105+25819+30020) = (24105+26117+30020) = (24105+25819+26270+30020)
R 0068	Mod : (25205+26526) = (26111+26526) = (26485+26526) = (26526+26999) = (26526+28382) = (26526+30241) = (26526+30631) = (26526+30635) = (26526+26999+26728) = (26526+26728+26999+31283+34864)

CODE	DESIGNATION
R 0070	Mod : (CFM 56-5-B4+25205+20268) = (CFM 56-5-B4+23885+20268) = (CFM 56-5-B4+26999+20268) = (CFM 56-5-B4+28382+20268) = (CFM 56-5-B4+30241+20268) = (CFM 56-5-B4+26485+20268) = (CFM 56-5-B4+30631+20268) = (CFM 56-5-B4+26999+28382+28495+20268) = (CFM 56-5-B4+25205+26999+28495+20268) = (CFM 56-5-B6+25205+20268+36311) = (CFM 56-5-B6+23885+20268+36311) = (CFM 56-5-B6+26999+20268+36311) = (CFM 56-5-B6+28382+20268+36311) = (CFM 56-5-B6+30241+20268+36311) = (CFM 56-5-B6+26485+20268+36311) = (CFM 56-5-B6+30631+20268+36311) = (CFM 56-5-B6+26999+28382+28495+20268+36311) = (CFM 56-5-B6+25205+26999+28495+20268+36311)
0071	Mod : (25205+28916) = (26111+28916) = (26485+28916) = (26999+28916) = (28382+28916) = (30241+28916) = (30631+28916) = (30635+28916) = (26999+28479) = (26999+28702) = (28382+28479) = (28382+28702)
R 0072	Mod : (20268+CFM 56-5-B4) = (20268+36311+CFM 56-5-B6)
R 0073	Mod : (25205+35871) = (23885+35871) = (26999+35871) = (28382+35871) = (30241+35871) = (26485+35871) = (30631+35871) = (26999+28382+28495+35871) = (25205+28495+26999+35871) = (25205+20268+35871) = (23885+20268+35871) = (26999+20268+35871) = (28382+20268+35871) = (28382+20268+35871) = (30241+20268+35871) = (26485+20268+35871) = (30631+20268+35871) = (26999+28382+28495+20268+35871) = (25205+26999+28495+20268+35871) = (20268+31701+25205+35871) = (20268+31701+23885+35871) = (20268+31701+26999+35871) = (20268+31701+28382+35871) = (20268+31701+30241+35871) = (20268+31701+30631+35871) = (20268+31701+26999+28382+28495+35871) = (20268+31701+25205+26999+28495+35871) = (20268+34818+25205+35871) = (20268+34818+23885+35871) = (20268+34818+26999+35871) = (20268+34818+28382+35871) = (20268+34818+30241+35871) = (20268+34818+26485+35871) = (20268+34818+30631+35871) = (20268+34818+26999+28382+28495+35871) = (20268+34818+25205+26999+28495+35871)
R 0074	Mod : 35871 = (35871+30020) = ((35871+24105+30020)
R 0075	Mod : 35871 = (31105+35220+35871) = (31070+35220+35871) = (30020+31070+35220+35871) = (30020+31105+35220+35871) = (31105+34041+35220+35871) = (31070+34041+35220+35871) = (21105+31070+35220+35871) = (24105+31105+35220+35871) = (30020+24105+31070+35220+35871) = (24105+30020+31105+35220+35871)
R 0076	Mod : (30020+31070+35220) = (30020+31105+35220) = (30020+24105+31070+35220) = (24105+30020+31105+35220)
R 0079	Mod : (21678+26485+26925) = (21678+26999+26925) = (21678+27646+26925) = (21678+30631+26925) = (21678+30635+26925) = (21678+26999+33497+26925) = (21678+26925+26999+27646) = (21678+26999+27620+33497+26925) = (21678+26999+27646+33497+26925)
R 0080	Mod : (21678+26999+27620+26925) = (21678+26925+26999+27620+27646)
R 0081	Mod : (21678+26999+27531+26925) = (21678+27531+27646+26925) = (21678+27531+30631+26925) = (21678+27531+30635+26925) = (21678+26485+27531+26925) = (21678+26999+27531+27620+33497+26925)
R 0083	Mod : (20268+36311) = (20268+25800+36311) = (20268+25530+26505+36311) = (20268+25800+25530+26505+36311)

CODE	DESIGNATION
R 0084	Mod : (25205+35871) = (23885+35871) = (26999+35871) = (28382+35871) = (30241+35871) = (26485+35871) = (30631+35871) = (26999+28382+28495+35871) = (25205+26999+28495+35871)
R 0085	Mod : (20268+36311) = (20268+24946+26965+36311) = (20268+24946+27773+36311) = (20268+25951+26965+36311) = (20268+25951+27773+36311) = (20268+26760+26965+36311) = (20268+26760+27773+36311) = (20268+26965+32150+36311) = (20268+26965+32238+36311) = (20268+26965+32239+36311) = (20268+26965+32311+36311) = (20268+27773+32150+36311) = (20268+27773+32238+36311) = (20268+27773+32239+36311) = (20268+27773+32311+36311) = (20268+26965+35040+36311) = (20268+27773+35040+36311)
R 0086	Mod : 35871 = (20268+35871) = (20268+31701+35871) = (20268+34818+35871)
R 0087	Mod : (32090+32499) = (28160+28917+32090+32499)
R 0088	Mod : (20268+21678+25404+26925+28160+36311+24946) = (20268+21678+25404+27773+28160+36311+24946) = (20268+21678+25404+31106+28160+36311+24946) = (20268+21678+24946+25404+26965+27773+28160+31106+ 36311)
R 0089	Mod : (20268+21678+25404+26925+28160+36311+24946) = (20268+21678+25404+27773+28160+36311+24946) = (20268+21678+25404+31106+28160+36311+24946)
R 0090	Mod : (20268+26965+36311+24946) = (20268+27773+36311+24946) = (20268+31106+36311+24946) = (20268+24946+26965+27773+31106+36311)
R 0092	Mod : (20268+26925+26965+36311+24946) = (20268+26925+27773+36311+24946) = (20268+26925+31106+36311+24946) = (20268+24946+26925+26965+27773+31106+36311)
R 0094	Mod : 33100 = 33300 = (33100+32650+32651) = (33300+32650+32651)
R 0095	STD = Mod : (33100+34856) = (33100+34898) = (33100+34997) = (32650+32651) = (33100+34856+32650+32651) = (33100+34898+32650+32651) = (33100+34997+32650+32651)
R 0096	Mod : 32650 = (33100+32650+34856) = (33100+32650+34898) = (33100+32650+34997)
R 0097	Mod : 31896 = 31897 = (31896+32332) = (31897+32333) = (31897+32401+35651)
R 0098	Mod: 31897 = 32929 = ((31897+35651)+V2527A5) = (31897+32333+32929)
R 0099	Mod: (20268+26925+26965) = (20268+27773+31106+35040) = (20268+27773+31106+32311+35040) = (20268+24946+27773+31106+35040) = (20268+24946+27773+31106+32150+35040) = (20268+24946+27773+31106+32311+35040) = (20268+26925+26965+27773+31106+32311+35040)
R 0101	Mod : (20268+24946+26965) = (20268+24946+27773) = (20268+25951+26965) = (20268+25951+27773) = (20268+26760+26965) = (20268+26760+27773) = (20268+26965+32150) = (20268+26965+32238) = (20268+26965+32239) = (20268+26965+32311) = (20268+27773+32150) = (20268+27773+32238) = (20268+27773+32239) = (20268+27773+32311) = (20268+26965+35040) = (20268+27773+35040) = (20268+27773+31106+35040+MXA) = (20268+24946+27773+31106+35040+MXA) = (20268+24946+27773+31106+35040+MXA) = (20268+24946+27773+31106+32311+35040+MXA)
R 0103	Mod : (20268+26925+31106) = (20268+26925+26965) = (20268+26925+26965+27773+31106+32311+35040)
R 0104	Mod : (20268+26965) = (20268+31106) = (20268+26925+27773+31106+32311+35040)

CODE	DESIGNATION
R 0105	Mod : (20268+24946+26965) = (20268+24946+27773) = (20268+25951+26965) = (20268+25951+27773) = (20268+26760+26965) = (20268+26760+27773) = (20268+26965+32150) = (20268+26965+32238) = (20268+26965+32239) = (20268+26965+32311) = (20268+27773+32150) = (20268+27773+32238) = (20268+27773+32239) = (20268+27773+32311) = (20268+26965+35040) = (20268+27773+35040) = (20268+26965+27773+31106+32311+35040)
R 0106	Mod: (20268+24946+26925+26965) = (20268+24946+26925+27773) = (20268+25951+26925+26965) = (20268+25951+26925+27773) = (20268+26760+26925+26965) = (20268+26760+26925+27773) = (20268+26925+26965+32150) = (20268+26925+26965+32238) = (20268+26925+26965+32239) = (20268+26925+26965+32311) = (20268+26925+27773+32150) = (20268+26925+27773+32238) = (20268+26925+27773+32239) = (20268+26925+27773+32311) = (20268+26925+26965+27773+31106+32311+35040)
R 0107	Mod: (20268+26965) = (20268+31106) = (20268+26965+27773+31106+32311+35040)
R 0108	Mod: (20268+26925+26965) = (20268+26925+26965+27773+31106+32311+35040)
R 0109	Mod: (20268+26925+26965) = (20268+26925+26965+27773+31106+32311+35040)
R 0110	Mod : (20268+26925+26965+28342) = (20268+24946+26925+28342+31106) = (20268+26925+26965+27773+28342+31106+32311+35040)
R 0111	(20268+31106+25647) = (20268+31106+ACA) = (20268+31106+MXA) = (20268+25647+26965) = (20268+26965+ACA) = (20268+26965+MXA) = (20268+24946+25647+27773+31106+32150+35040+MXA) = (20268+24946+25647+27773+31106+35040+MXA) = (20268+24946+27773+31106+MXA) = (20268+24946+27773+31106+35040+MXA) = (20268+27773+31106+32311+35040+MXA)
R 0112	Mod: (20268+26925+26965) = (20268+26925+26965+27773+31106+32311+35040)
R 0114	Mod: (20268+21678+25404+26965) = (20268+21678+25404+31106) = (20268+21678+25404+26965+27773+31106+32311+35040)
R 0115	Mod : (20268+21678+24946+31106+MXA) = (20268+21678+31106+32311+MXA) = (20268+21678+27773+31106+35040+MXA) = (20268+21678+24946+27773+31106+35040+MXA) = (20268+21678+24946+27773+31106+32150+35040+MXA) = (20268+21678+24946+27773+31106+32311+35040+MXA)
R 0117	Mod : 20268+21678+25404+28160+27773+24946 = (20268+21678+24946+25404+28160+31106) = (20268+21678+25404+25951+28160+31106) = (20268+21678+25404+28160+31106+32311) = (20268+21678+25404+28160+31106+32238) = (20268+21678+25404+26965+27773+31106+32311+35040)
R 0118	Mod : (20268+21678+24946+25404+27773+28160) = (20268+21678+25404+28160+31106+32311) = (20268+21678+24946+25404+26965+27773+28160) = (20268+21678+25404+26965+27773+31106+32311+35040)
R 0119	Mod : (20268+21678+25404) = (20268+21678+25404+26965+27773+28160+31106+32311+35040)
R 0121	Mod : (20268+21678+24044+25404) = (20268+26925+26965+27773+31106+32311+35040)

CODE	DESIGNATION
R 0122	Mod : (20268+24946+26965) = (20268+24946+27773) = (20268+25951+26965) = (20268+25951+27773) = (20268+26760+26965) = (20268+26760+27773) = (20268+26965+32150) = (20268+26965+32238) = (20268+26965+32239) = (20268+26965+32311) = (20268+27773+32150) = (20268+27773+32238) = (20268+27773+32239) = (20268+27773+32311) = (20268+26965+35040) = (20268+27773+35040) = (20268+26965+27773+31106+32311+35040)
R 0125	Mod : (20268+24946+26965) = (20268+24946+27773) = (20268+25951+26965) = (20268+25951+27773) = (20268+26760+26965) = (20268+26760+27773) = (20268+26965+32150) = (20268+26965+32238) = (20268+26965+32239) = (20268+26965+32311) = (20268+27773+32150) = (20268+27773+32238) = (20268+27773+32239) = (20268+27773+32311) = (20268+26965+35040) = (20268+27773+35040) = (20268+26965+27773+31106+32311+35040)
R 0126	Mod: (20268+26965) = (20268+31106) = (20268+26965+27773+31106+32311+35040)
R 0127	Mod: (20268+28342+31106) = (20268+28342+26965) = (20268+26965+27773+28342+31106+32311+35040)
R 0128	Mod: (20268+31106+25647) = (20268+31106+ACA) = (20268+31106+MXA) = (20268+25647+26965) = (20268+26965+ACA) = (20268+26965+MXA) = (20268+24946+27773+31106+35040+MXA) = (20268+27773+31106+32311+35040+MXA) = (20268+24946+25647+27773+31106+35040+MXA) = (20268+24946+25647+27773+31106+32150+35040+MXA) =
R 0130	Mod : (26485+28916+34637) = (26526+26728+26999+28479+31283+34637) = (26526+26728+26999+28382+28479+31283+34637) = (26526+26999+28479+34637)
R 0131	Mod : (25205+26526+28916) = (26111+26526+28916) = (26526+26999+28479) = (26526+26999+28702) = (26526+28382+28916) = (26526+28916+30631) = (26526+28916+30635) = (26526+26999+28916) = (26526+26999+28382+28479) = (26526+26999+28382+28702) = (26526+26728+26999+28479)
0132	Mod : 20268 = (20268+25800) = (20268+24404+35404) = (20268+27727+35404) = (20268+24404+27727+35404) = (20268+24404+25800+35404) = (20268+25800+27727+35404) = (20268+24404+25800+27727+35404)
R 0133	Mod : (20268+26965) = (20268+31106) = (20268+26965+27773+31106+32311+35040)
R 0134	Mod : (20268+24946+26965) = (20268+24946+27773) = (20268+25951+26965) = (20268+25951+27773) = (20268+26760+26965) = (20268+26760+27773) = (20268+26965+32150) = (20268+26965+32238) = (20268+26965+32239) = (20268+26965+32311) = (20268+27773+32150) = (20268+27773+32238) = (20268+27773+32239) = (20268+27773+32311) = (20268+26965+35040) = (20268+27773+35040) = (20268+26965+27773+31106+32311+35040)
R 0135	Mod : (20268+25647) = (MXA+20268+26965+27773+31106+32311+35040)
R 0136	Mod : 20268 = (20268+26965+27773+31106+32311+35040)
R 0137	Mod: (20268+31106+25647) = (20268+31106+ACA) = (20268+31106+MXA) = (20268+25647+26965) = (20268+26965+ACA) = (20268+26965+MXA) = (20268+27773+31106+32311+35040+MXA) = (20268+26965+27773+31106+32311+35040+MXA) = (20268+24946+27773+31106+32311+35040+MXA) = (20268+24946+25647+27773+31106+32311+35040+MXA)
R 0138	Mod: (20268+28342+31106) = (20268+28342+26965) = (20268+26965+27773+28342+31106+32311+35040)

CODE	DESIGNATION
R 0139	Mod : (20268+24946+26965) = (20268+24946+27773) = (20268+25951+26965) = (20268+25951+27773) = (20268+26760+26965) = (20268+26760+27773) = (20268+26965+32150) = (20268+26965+32238) = (20268+26965+32239) = (20268+26965+32311) = (20268+27773+32150) = (20268+27773+32238) = (20268+27773+32239) = (20268+27773+32311) = (20268+26965+35040) = (20268+27773+35040) = (20268+26965+27773+31106+32311+35040)
R 0141	Mod : (21678+22536+27522+33100) = (21678+22536+27522+33300) = (21678+23529+27522+33100) = (21678+23529+27522+33300) = (21678+23227+27522+33100) = (21678+23227+27522+33300)
R 0142	Mod : (21678+22536+27522) = (21678+23227+27522) = (21678+23529+27522) = (21678+22536+27522+33100+34856) = (21678+22536+27522+33100+34898) = (21678+22536+27522+33100+34997) = (21678+23227+27522+33100+34856) = (21678+23227+27522+33100+34898) = (21678+23227+27522+33100+34997) = (21678+23529+27522+33100+34856) = (21678+23529+27522+33100+34898) = (21678+23227+27522+33100+34898)
0143	Mod : (20268+V2533) = (20268+31607+V2530)
0144	Mod : (20268+21678+25404) = (20268+21678+25404+28160+28917)
0148	Mod : (20268+21678+24044+25647) = (20268+21678+24044+25404+ACA)
0150	Mod : (20268+21678+25404+25647) = (20268+21678+25404+MXA)
R 0152	Mod : (28258+30020+26526) = (30470+30020+26526) = (26438+30020+26526) = (27624+30020+26526) = (23888+30020+26526) = (26526+27624+30020+31276) = (26526+27498+30020+30470+31276) = (26526+27498+27624+30020+31276) = (26526+27498+30020+31276+34330) = (26526+27498+30020+31276+34637+35436)
R 0153	Mod : (28258+20343+26526) = (28258+31276+26526) = (30470+20343+26526) = (30470+31276+26526) = (26438+20343+26526) = (27624+20343+26526) = (23888+20343+26526) = (23888+31276+26526) = (26438+31276+26526) = (27624+31276+26526) = (28258+20343+27498+26526) = (30470+20343+27498+26526) = (26438+20343+27498+26526) = (27624+20343+27498+26526) = (23888+20343+27498+26526) = (28258+31276+27498+26526) = (30470+31276+27498+26526) = (26438+31276+27498+26526) = (27624+31276+27498+26526) = (23888+31276+27498+26526) = (26526+27498+31276+34330) = (26526+27498+31276+34331) = (26526+27498+31276+34332) = (26526+27498+31276+34333) = (26526+27498+31276+34334) = (26526+27498+31276+35436) = (26526+27498+31276+34331+34637) = (26526+27498+31276+34333+34637) = (26526+27498+31276+34332+34637) = (26526+27498+31276+34637+35436)
R 0154	Mod : 22562 = (20063+22562) = (20151+22562) = (20063+20151+22562) = (22562+31495+35270) = (20063+22562+31495+35270) = (20063+20151+31495+35270+35864) = (20063+22562+31495+35270+35864) = (20063+31495+35270+35864)
0155	Mod : (24215+24588+24794) = (24215+24588+24794+32090)
0156	Mod : (24105+24215+24588+24794) = (24215+24588+24794+28160) = (24105+24215+24588+24794+32090) = (24215+24588+24794+28160+32090)
0158	Mod : (22013+24794+28652) = (22013+24215+24588+24794+28652)
0159	Mod : 32090 = (22013+24215+24588+24794+32090)

CODE	DESIGNATION
R 0160	Mod: (24215+24588+24794+26925+35871+32090) = (24215+24588+24794+26925+35220+32090)
0161	Mod : 24215 = 24588 = 25534 = (24215+24588) = (24215+25534) = (24215+24588+25534) = (24215+24588+28917) = (24215+28160+28917) = (24588+28160+28917) = (25534+28160+28917) = (24215+24588+28160+28917)
0162	Mod : (22013+24215) = (22013+24588) = (22013+25534) = (24105+24215) = (24105+24588) = (24105+25534) = (24215+28160) = (24588+28160) = (25534+28160) = (22013+24215+24588) = (24105+24215+24588) = (24215+24588+28160)
R 0163	Mod : (24215+24588+24794+24215+35871+32090) = (22013+24215+24588+24794+35871+32090) = (24105+24215+24588+24794+35871+32090)
0164	Mod : (22013+24215+32090) = (22013+24588+32090) = (22013+25534+32090) = (24105+24215+32090) = (24105+24588+32090) = (24105+25534+32090) = (28160+24215+32090) = (28160+24588+32090) = (28160+25534+32090) = (22013+24215+24588+32090) = (24105+24215+24588+32090) = (24215+24588+28160+32090)
R 0166	Mod: (21678+27522+35227) = (21678+27522+35865)
R 0167	Mod : (20268+24946+26965+34041) = (20268+24946+31106+34041) = (20268+24946+27773+34041) = (20268+27773+31106+32238+34041) = (20268+24946+26965+27773+31106+34041)
R 0170	Mod : (20268+26925+26965+27773+31106+32311+35040) = (20268+24946+26965+26925+27773+31106)
0171	Mod : (20268+24946+26965) = (20268+24946+27773) = (20268+25951+26965) = (20268+25951+27773) = (20268+26760+26965) = (20268+26760+27773) = (20268+26965+32150) = (20268+26965+32238) = (20268+26965+32239) = (20268+26965+32311) = (20268+27773+32150) = (20268+27773+32238) = (20268+27773+32239) = (20268+27773+32311) = (20268+26965+35040) = (20268+27773+35040)
0172	Mod : (20268+25647) = (20268+ACA) = (20268+MXA)
0173	Mod : (20268+25647) = (20268+ACA)
0174	Mod : (20268+24044+25647) = (20268+24044+ACA)
R 0176	Mod: (20268+24946+26925+26965) = (20268+24946+26925+27773) = (20268+25951+26925+26965) = (20268+25951+26925+27773) = (20268+26760+26925+26965) = (20268+26760+26925+27773) = (20268+26925+26965+32150) = (20268+26925+26965+32238) = (20268+26925+26965+32239) = (20268+26925+26965+32311) = (20268+26925+27773+32150) = (20268+26925+27773+32238) = (20268+26925+27773+32239) = (20268+26925+27773+32311) = (20268+26965+26925+27773+31106+32311+35040)
R 0177	Mod : (20268+24946+31106+34041) = (20268+27773+31106+32238+34041)
R 0178	Mod : (20268+24044+26925) = (20268+24044+26925+27773+31106)
R 0179	Mod : (22013+32456) = (22013+27846+28479+28721) = (22013+27846+28479+28960) = (22013+27846+28721+28916) = (22013+27846+28916+28960) = (22013+27846+28479+32011) = (22013+27846+28916+32011) = (22013+28479+28960+30439) = (22013+28479+28721+30439) = (22013+28479+30439+32011)
R 0181	Mod : (MXA+20268+27773+31106+35040) = (MXA+20268+27773+31106+32311+35040) = (MXA+20268+24946+27773+31106+32150+35040) = (MXA+20268+24946+27773+31106+32311+35040)
0182	Mod : (20268+31106+25647) = (20268+31106+ACA) = (20268+31106+MXA) = (20268+26965+25647) = (20268+26965+ACA) = (20268+26965+MXA)

CODE	DESIGNATION
R 0186	Mod : $56-5-B4 = (56-5-B6+36311) = (56-5-B4+28160+28917) = (56-5-B6+36311+28160+28917)$
0187	Mod : $(20268+26965) = (20268+31106)$
0188	Mod : $(24105+24215+24588+24794+28238+32635) = (24105+24215+24588+24794+28238+32090+32635)$
R 0189	Mod : $(STD = (28160+28917))/(56-5-A1/A3/V2500/V2527/V2527EA5)$
R 0191	Mod : $(20268+25647+26965) = (20268+25647+27773) = (20268+24946+25647+26965) = (20268+24946+25647+27773) = (20268+25647+25951+26965) = (20268+25647+25951+27773) = (20268+25647+26760+26965) = (20268+25647+26760+27773) = (20268+25647+26965+32150) = (20268+25647+26965+32238) = (20268+25647+26965+32239) = (20268+25647+26965+32311) = (20268+25647+27773+32150) = (20268+25647+27773+32238) = (20268+25647+27773+32239) = (20268+25647+27773+32311) = (20268+25647+26965+35040) = (20268+25647+27773+35040) = (24946+26965+ACA) = (24946+27773+ACA) = (25951+26965+ACA) = (25951+27773+ACA) = (26760+26965+ACA) = (26760+27773+ACA) = (26965+32150+ACA) = (26965+32238+ACA) = (26965+32239+ACA) = (26965+32311+ACA) = (27773+32150+ACA) = (27773+32238+ACA) = (27773+32239+ACA) = (27773+32311+ACA) = (26965+35040+ACA) = (27773+35040+ACA) = (20268+25647+26965+ACA) = (20268+25647+27773+ACA) = (20268+24946+25647+26965+ACA) = (20268+24946+25647+27773+ACA) = (20268+25647+25951+26965+ACA) = (20268+25647+25951+27773+ACA) = (20268+25647+26760+26965+ACA) = (20268+25647+26760+27773+ACA) = (20268+25647+26965+32150+ACA) = (20268+25647+26965+32238+ACA) = (20268+25647+26965+32239+ACA) = (20268+25647+26965+32311+ACA) = (20268+25647+27773+32150+ACA) = (20268+25647+27773+32238+ACA) = (20268+25647+27773+32239+ACA) = (20268+25647+27773+32311+ACA) = (20268+25647+26965+35040+ACA) = (20268+25647+27773+35040+ACA)$

CODE	DESIGNATION
R 0192	Mod : $(20268+24946+25647+26965) = (20268+24946+25647+27773) =$ $(20268+25647+25951+26965) = (20268+25647+25951+27773) =$ $(20268+25647+26760+26965) = (20268+25647+26760+27773) =$ $(20268+25647+26965+32150) = (20268+25647+26965+32238) =$ $(20268+25647+26965+32239) = (20268+25647+26965+32311) =$ $(20268+25647+27773+32150) = (20268+25647+27773+32238) =$ $(20268+25647+27773+32239) = (20268+25647+27773+32311) =$ $(20268+25647+26965+35040) = (20268+25647+27773+35040) =$ $(24946+26965+ACA) = (24946+27773+ACA) =$ $(25951+26965+ACA) = (25951+27773+ACA) =$ $(26760+26965+ACA) = (26760+27773+ACA) =$ $(26965+32150+ACA) = (26965+32238+ACA) =$ $(26965+32239+ACA) = (26965+32311+ACA) =$ $(27773+32150+ACA) = (27773+32238+ACA) =$ $(27773+32239+ACA) = (27773+32311+ACA) =$ $(26965+35040+ACA) = (27773+35040+ACA) =$ $(20268+24946+25647+26965+ACA) =$ $(20268+24946+25647+27773+ACA) =$ $(20268+25647+25951+26965+ACA) =$ $(20268+25647+25951+27773+ACA) =$ $(20268+25647+26760+26965+ACA) =$ $(20268+25647+26760+27773+ACA) =$ $(20268+25647+26965+32150+ACA) =$ $(20268+25647+26965+32238+ACA) =$ $(20268+25647+26965+32239+ACA) =$ $(20268+25647+26965+32311+ACA) =$ $(20268+25647+27773+32150+ACA) =$ $(20268+25647+27773+32238+ACA) =$ $(20268+25647+27773+32239+ACA) =$ $(20268+25647+27773+32311+ACA) =$ $(20268+25647+26965+35040+ACA) =$ $(20268+25647+27773+35040+ACA)$
R 0195	Mod : $(20343+56-5-A4/A5/B5/B6/B7) = (20343+V2522/V2524/2527MA5) =$ $(31276+27498+56-5-A4/A5/B5/B6/B7) =$ $(31276+27498+V2522/V2524/2527MA5)$
0196	Mod : $(21678+26999+27531) = (21678+27531+27646) =$ $(21678+27531+30631) = (21678+27531+30635) =$ $(21678+26485+27531) = (21678+26999+27531+27620+33497)$
0197	Mod : $(21678+26485) = (21678+26999) = (21678+27646) =$ $(21678+30631) = (21678+30635) = (21678+26999+33497) =$ $(21678+26999+27620+33497) = (21678+26999+27646+33497)$
R 0198	Mod : $(V2522/V2524/2527MA5+20343) = (56-5-A4/A5/B5/B6/B7+20343) =$ $(V2522/V2524/2527MA5+31276) = (56-5-A4/A5/B5/B6/B7+31276) =$ $(V2522/V2524/2527MA5+20343+27498) =$ $(56-5-A4/A5/B5/B6/B7+20343+27498) =$ $(V2522/V2524/2527MA5+31276+27498) =$ $(56-5-A4/A5/B5/B6/B7+31276+27498)$
0199	Mod : $31896 = 31897 = 32401 = 32402 = 32475 = 32929 =$ $(31896+32332+32475) = (31897+32333+32929)$
0200	Mod : $(20268+25647+26965) = (20268+25647+31106)$
0202	Mod : $20268 = (20268+25800)/(T=L)$
0203	Mod : $20268 = (20268+25800)+56-5-B8+L)$
0205	Mod : $(20268+31106) = (20268+26965)$
R 0206	Mod : $(20343+V2500/V2527/V2527E) =$ $(27498+31276+V2500/V2527/V2527E)$
0208	Mod : $(20268+24946+26965) = (20268+24946+27773) =$ $(20268+26760+26965) = (20268+26760+27773) =$ $(20268+26965+32150) = (20268+26965+32238) =$ $(20268+26965+32239) = (20268+26965+32311) =$ $(20268+27773+32150) = (20268+27773+32238) =$ $(20268+27773+32239) = (20268+27773+32311)$
0209	Mod : $(21678+21706+21768) = (21678+21706+21768+21858+26347)$
R 0210	Mod : $((20343 + 31276)/V2500/V2527/V2527E) = ((20343+27498) =$ $(27498+31276)/V2500/V2527/V2527E)$

CODE	DESIGNATION
R 0212	Mod : 20268 = (20268+36311)
0213	Mod : (24794+32090) = (22013+24215+24588+24794+28652+32090) = (22013+24215+24588+24794+28652+30422+32090)
R 0215	Mod : 20343 = 31276 = (20343+27498) = (31276+27498)
R 0219	Mod : (20343+22013/V2530/V2533) = (31276+22013/V2530/V2533) = (20343+27498+22013/V2530/V2533) = (31276+27498+22013/V2530/V2533) = (20343+22013/B1/B2/B3) = (31276+22013/B1/B2/B3) = (20343+27498+22013/B1/B2/B3) = (31276+27498+22013/B1/B2/B3)
R 0223	Mod : (25534+32090+32499+35218) = (24215+24588+32090+32499+35218)
R 0224	Mod : (22013+24215+24588+32090+32499+35219) = (24105+24215+24588+32090+32499+35218) = (24105+24215+24588+32090+32499+35219) = (24215+24588+28160+32090+32499+35219) = (22013+24215+24588+32090+32499+35218) = (24215+24588+28160+32090+32499+35218)
R 0225	Mod : (56-5-A1/A3/B4) = (36311+56-5-B6)
R 0226	Mod : (20343+56-5-A1/A3/B4) = (27498+31276+56-5-A1/A3/B4) = (20343+36311+56-5-B6) = (27498+31276+36311+56-5-B6)
R 0227	Mod : (20343+56-5-A1/A3/B4) = (31276+56-5-A1/A3/B4) = (27498+31276+56-5-A1/A3/B4) = (20343+27498+56-5-A1/A3/B4) = (20343+36311+56-5-B6) = (31276+36311+56-5-B6) = (27498+31276+36311+56-5-B6) = (20343+27498+36311+56-5-B6)
R 0228	Mod : (27498+56-5-A1/A3/B4) = (27498+36311+56-5-B6)
R 0229	Mod : 24105 = (24105+26999+28495)
R 0230	Mod : (23885+24105) = (25205+24105) = (26485+24105) = (26999+24105) = (28382+24105) = (30241+24105) = (30631+24105) = (25205+26999+28495+24105) = (26999+28382+28495+24105)
R 0231	Mod : 34041 = (34041+26999+28945)
R 0233	Mod : 20139 = (20139+26999+28495)
R 0234	Mod : (23885+20139) = (25205+20139) = (26485+20139) = (26999+20139) = (28382+20139) = (30241+20139) = (30631+20139) = (25205+26999+28495+20139) = (26999+28382+28495+20139)
R 0235	Mod : STD = (31283+34864) = (31283+34861) = (31283+34862) = (30660+31283+34862)
0236	Mod: (24645+26925+30020+31283) = (24105+24645+26925+30020+31283)
0237	Mod: (20268+24946+26965+25647) = (20268+24946+27773+25647) = (20268+25951+26965+25647) = (20268+25951+27773+25647) = (20268+26760+26965+25647) = (20268+26760+27773+25647) = (20268+26965+32150+25647) = (20268+26965+32238+25647) = (20268+26965+32239+25647) = (20268+26965+32311+25647) = (20268+27773+32150+25647) = (20268+27773+32238+25647) = (20268+27773+32239+25647) = (20268+27773+32311+25647) = (20268+26965+25647+35040) = (20268+27773+25647+35040)
0238	Mod: (20268+28342+31106) = (20268+28342+26965)
R 0241	Mod : STD = 30020 = (26999+28495) = (24105+30020) = (26999+28495+30020) = (26999+28495+24105+30020)

CODE	DESIGNATION
R 0246	Mod : 25205 = 23885 = 26999 = 28382 = 30241 = 26485 = 30631 = (23885+30020) = (25205+30020) = 26485+30020) = (26999+30020) = (28382+30020) = (30241+30020) = (30631+30020) = (26999+28382+28495) = (25205+26999+28495) = (23885+24105+30020) = (25205+24105+30020) = (26485+24105+30020) = (26999+24105+30020) = (28382+24105+30020) = (30241+24105+30020) = (30631+24105+30020) = (25205+26999+28495+30020) = (26999+28382+28495+30020) = (25205+26999+28495+24105+30020) = (26999+28382+28495+24105+30020)
0248	Mod: 20268 = (20268+25800) = (20268+25530+26505) = (20268+25800+25530+26505)
0249	Mod: 32475 = 32929 = (31897+32929) = (31896+32475) = (31896+32402) = (31897+31401) = (31896+32332+32475) = (31897+32333+32929)
0250	Mod: (20268+24946+26925+26965) = (20268+24946+26925+27773) = (20268+25951+26925+26965) = (20268+25951+26925+27773) = (20268+26760+26925+26965) = (20268+26760+26925+27773) = (20268+26925+26965+32150) = (20268+26925+26965+32238) = (20268+26925+26965+32239) = (20268+26925+26965+32311) = (20268+26925+27773+32150) = (20268+26925+27773+32238) = (20268+26925+27773+32239) = (20268+26925+27773+32311)
0251	Mod: 31896 = 32475 = (31896+32332+32475) = (31896+25530+26505) = (32475+25530+26505) = (31896+32332+32475+25530+26505)
0252	Mod: (31896+25530) = (32475+25530) = (31896+32332+32475+25530) = (31896+25530+27727) = (32475+25530+27727) = (31896+32332+32475+25530+27727) = (31896+27727) = (31896+32332+32475+27727)
0253	Mod: (20268+21678+24946+26965) = (20268+21678+24946+27773) = (20268+21678+25951+26965) = (20268+21678+25951+27773) = (20268+21678+26760+26965) = (20268+21678+26760+27773) = (20268+21678+26965+32150) = (20268+21678+26965+32238) = (20268+21678+26965+32239) = (20268+21678+26965+32311) = (20268+21678+27773+32150) = (20268+21678+27773+32238) = (20268+21678+27773+32239) = (20268+21678+27773+32311)
0255	Mod: 31896 = 32475 = (31896+32332+32475)
0256	Mod: 25800 = (25800+31896+32332)
0257	Mod: (20268+24946+26965) = (20268+24946+27773) = (20268+25951+26965) = (20268+25951+27773) = (20268+26760+26965) = (20268+26760+27773) = (20268+26965+32150) = (20268+26965+32238) = (20268+26965+32239) = (20268+26965+32311) = (20268+27773+32150) = (20268+27773+32238) = (20268+27773+32239) = (20268+27773+32311)
0258	Mod: (31896+32332) = (25800+31896) = (25800+32475) = (25800+31896+32332+32475)
0259	Mod: (31896=32475) = (31896+32332+32475)
R 0260	Mod : (20268+21678+25404+27773+31106+32311)
R 0261	Mod: (20268+21678+25404+27773+28160+31106+32238) = (20268+21678+25404+26965+27773+28160+31106+32311+35040)
0262	Mod : (CFM 56-5-b4+28160) = (CFM 56-5-b5/b6/b7/b8)
0266	Mod : (56-5-A4/A5) = (56-5-A4/A5+31896+32332)
0267	STD = Mod : (31897+32333)
0268	Mod : (56-5-B5/B6/B7) = (56-5-B5/B6/B7+31896+32332)
R 0273	Mod : (V2522/V2524/2527MA5+20343) = (56-5-A1/A3/A4/A5/B4/B5/B6/B7+20343) = (V2522/V2524/2527MA5+31276) = (56-5-A1/A3/A4/A5/B4/B5/B6/B7+31276) = (V2522/V2524/2527MA5+20343+27498) = (56-5-A1/A3/A4/A5/B4/B5/B6/B7+20343+27498) = (V2522/V2524/2527MA5+31276+27498) = (56-5-A1/A3/A4/A5/B4/B5/B6/B7+31276+27498)

CODE	DESIGNATION
R 0274	Mod : $20343 = 31276 = (20343 + 31276) = (20343 + 27498) = (31276 + 27498)$
R 0276	Mod : $(20343 + 22013/V2530/V2533) = (31276 + 22013/V2530/V2533) = (20343 + 27498 + 22013/V2530/V2533) = (31276 + 27498 + 22013/V2530/V2533) = (20343 + 22013/B1/B2/B3) = (31276 + 22013/B1/B2/B3) = (20343 + 27498 + 22013/B1/B2/B3) = (31276 + 27498 + 22013/B1/B2/B3)$
R 0277	Mod : $(27498 + 22013/V2530/V2533) = (27498 + 22013//B1/B2/B3)$
0278	Mod : $(22013 + 24215) = (22013 + 24588) = (22013 + 25534) = (22013 + 24215 + 24588) = (22013 + 24588 + 32090) = (24215 + 24588 + 28160) = (22013 + 24215 + 24588 + 32090)$
R 0279	Mod : $(20268 + 24946 + 26965 + 34041) = (20268 + 24946 + 31106 + 32238 + 34041) = (20268 + 24946 + 26965 + 27773 + 31106 + 34041)$
R 0280	Mod : $(20268 + 26965 + 36311 + 24946) = (20268 + 27773 + 36311 + 24946) = (20268 + 24946 + 26965 + 27773 + 36311)$
0283	Mod : $(22013 + 24215 + 24588 + 24794 + 31283 + 32090) = (24105 + 24215 + 24588 + 24794 + 31283 + 32090) = (24215 + 24588 + 24794 + 28160 + 31283 + 32090)$
R 0284	Mod : $(20268 + 21678 + 27773 + 31106 + 32311) = (20268 + 21678 + 24646 + 27773 + 31106 + 32150)$
R 0286	Mod : $(20268 + 21678 + 24044 + 25404 + 34818) = (20268 + 21678 + 24044 + 25404 + 27773 + 31106 + 31701)$
R 0287	Mod : $(20268 + 21678 + 25404 + 25647) = (20268 + 21678 + 25404 + 27773 + 31106 + 32311 + 35040) = (20268 + 21678 + 25404 + 26965 + 27773 + 31106 + 32311 + 35040) = (20268 + 21678 + 24946 + 25404 + 27773 + 31106 + 25040) = (20268 + 21678 + 24946 + 25647 + 27773 + 31106 + 35040 + 25404) = (20268 + 21678 + 24946 + 25647 + 27773 + 31106 + 32150 + 35040 + 25404)$
R 0288	Mod : $(20268 + 21678 + 24946 + 25404 + 27773 + 28160 + 31106 + 34041) = (20268 + 21678 + 25404 + 27773 + 28160 + 31106 + 32238 + 34041) = (20268 + 21678 + 24946 + 25404 + 26965 + 27773 + 28160 + 31106 + 34041)$
R 0292	Mod : $(20268 + 21678 + 24946 + 25404 + 28160 + 31106) = (20268 + 21678 + 25404 + 28160 + 31106 + 32311) = (20268 + 21678 + 24946 + 25404 + 26965 + 27773 + 28160 + 31106) = (20268 + 21678 + 25404 + 26965 + 27773 + 28160 + 31106 + 32311)$
0296	Mod : $20343 = 31276 = (20343 + 27498) = (31276 + 27498)$
0297	Mod : $(28258 + 20343) = (30470 + 20343) = (26438 + 20343) = (27624 + 20343) = (23888 + 20343) = (28258 + 31276) = (30470 + 31276) = (26438 + 31276) = (27624 + 32176) = (23888 + 31276) = (28258 + 20343 + 27498) = (30470 + 20343 + 27498) = (26438 + 20343 + 27498) = (27624 + 20343 + 27498) = (23888 + 30343 + 27498) = (28258 + 31276 + 27498) = (30470 + 31276 + 27498) = (26438 + 31276 + 27498) = (27624 + 31276 + 27498) = (23888 + 32176 + 27498)$
0316	Mod : $(20268 + 56-5-B3) = (20268 + 31701 + 56-5-B1) = (20268 + 34818 + 56-5-B1)$
0325	Mod : $25529 = 25819 = 26117 = 26270 = (25529 + 25819) = (26117 + 26270)$
0326	Mod : $(22013 + 25529) = (22013 + 26117) = (22013 + 26270) = (22013 + 25819) = (22013 + 26117 + 26270)$
0327	Mod : $(24105 + 25529) = (24105 + 25819) = (24105 + 26117) = (24105 + 26270) = (24105 + 26117 + 26270) = (24105 + 25529 + 25819)$
0329	Mod : $(20268 + 28342) = (20268 + 26965 + 28342) = (20268 + 28342 + 31106)$
0330	Mod : $20268 = (20268 + 25800) = (20268 + 24404) = (20268 + 24404 + 25502) = (20268 + 24404 + 25800) = (20268 + 25800 + 27727) = (20268 + 24404 + 25502 + 25800) = (20268 + 24404 + 25800 + 27727)$

CODE	DESIGNATION
0331	Mod : (20268+24946+26965+34041) = (20268+24946+27773+34041) = (20268+25951+26965+34041) = (20268+25951+27773+34041) = (20268+26760+26965+34041) = (20268+26760+27773+34041) = (20268+26965+32150+34041) = (20268+26965+32238+34041) = (20268+26965+32239+34041) = (20268+26965+32311+34041) = (20268+27773+32150+34041) = (20268+27773+32238+34041) = (20268+27773+32239+34041) = (20268+27773+32311+34041) = (20268+26965+34041+35040) = (20268+27773+34041+35040)
0344	Mod : (24946+26965) = (24946+27773) = (25951+26965) = (25951+27773) = (26760+26965) = (26760+27773) = (26965+32150) = (26965+32238) = (26965+32239) = (26965+32311) = (27773+32150) = (27773+32238) = (27773+32239) = (27773+32311) = (26965+35040) = (27773+35040)
0347	Mod : (20268+21678+24946+25404+27773+31106) = (20268+21678+25404+26965+27773+28160+28917+31106+ 32311)
0350	Mod : (20268+21678+24946+25404+27773+31106) = (20268+21678+24946+25404+27773+28160+28917+31106)
0352	Mod : (26526+30020) = (26526+30020+31276) = (26526+27498+30020+31276)
0357	Mod : (20268+24946+27773+31106) = (20268+27773+31106+32311) = (20268+26965+27773+31106+32311)
0358	Mod : (20268+27773+31106) = (20268+24946+27773+31106) = (20268+27773+31106+32238)
0360	Mod : (20268+24946+27773) = (20268+27773+32311) = (20268+26965+27773+32311)
0362	Mod : (20268+24946+26965) = (20268+24946+27773) = (20268+26760+26965) = (20268+26760+27773) = (20268+26965+32150) = (20268+26965+32238) = (20268+26965+32239) = (20268+26965+32311) = (20268+27773+32150) = (20268+27773+32238) = (20268+27773+32239) = (20268+27773+32311) = (20268+26965+27773+32311)
0365	Mod : (20268+21678+25404+27773+31106+32311) = (20268+21678+25404+27773+28160+28917+31106+32311) = (20268+21678+25404+26965+27773+28160+28917+31106+ 32311)
0367	Mod : STD = 20151 = (31495+35270) = (20063+20151) = (20063+23092) = (20063+31112) = (20063+20151+31495+35270)
0370	Mod : (20268+27773+31106+32311) = (20268+24946+27773+31106+32150) = (20268+26965+27773+31106+32311)
0372	Mod : (20268+27773+32311) = (20268+24946+27773+32150) = (20268+26965+27773+32311)
0374	Mod : 22013 = (22013+31495+35270) = (20063+20151+22013+31495+35270) = (20063+22013) = (22013+23092) = (20063+20151+2013) = (20063+22013+23092)
0375	Mod : (22013+22562) = (22013+22562+31495+35270) = (20063+22013+22562+31495+35270) = (20063+22013+22562) = (20151+22013+22562) = (20063+20151+22013+22562)
0376	Mod : (20151+31495) = (31112+31495) = (31495+23062) = (20063+20151+31495) = (20063+31112+31495)
0378	Mod : (22151+22013+31495) = (22013+31112+31495) = (22013+23092+31495) = (20063+20151+22013+31495) = (20063+22013+31112+31495)
0380	Mod : (22013+25419) = (24105+25419) = (24701+25419) = (22013+25419+27620) = (24105+25419+27620) = (24701+25419+27620)
0381	Mod : (22013+25419+26925) = (24105+25419+26925) = (24701+25419+26925) = (22013+25419+26925+27620) = (24105+25419+26925+27620) = (24701+25419+26925+27620)

CODE	DESIGNATION
0382	Mod : STD = 27620 = (26358+30980)
0383	Mod : (26358+28238) = (26358+27620+28238)
0385	Mod : (20343+26526) = (26526+31276) = (20343+26526+27498) = (26526+27498+31276) = ((26526+27498+31276+34637)
0387	Mod : (26111+34637) = (26111+26526+34637)
0389	Mod : 34637 = (26526+34637) = (26526+27046+31375+34637)
0394	Mod : 34041 = (20268+34041)
R 0398	Mod : (21678+22536+27522+35227) = (21678+23227+27522+35227) = (21678+23529+27522+35227) = (21678+22536+27522+35865) = (21678+23227+27522+35865) = (21678+23529+27522+35865)
R 0399	Mod : (21678+22536+27522+33100+35227) = (21678+22536+27522+33300+35227) = (21678+23529+27522+33100+35227) = (21678+23529+27522+33300+35227) = (21678+22536+27522+33100+35865) = (21678+22536+27522+33300+35865) = (21678+23529+27522+33100+35865) = (21678+23529+27522+33300+35865)
0400	Mod : (22013+34313) = (22013+34809) = (20024+22013+34313) = (20024+22013+34809)
0401	Mod : 20024 = (20024+31283+34861) = (20024+31283+34862) = (20024+31283+34864)
0402	Mod : 22013 = (22013+20024) = (20024+22013+31283+34861) = (20024+22013+31283+34862) = (20024+22013+31283+34864)
0403	Mod : (22013+31283) = (20024+22013+31283)
0404	Mod : STD = (31283+34864) = (31283+34861) = (31283+34862)
0407	Mod : (30020+26925) = (24105+30020+26925)
0408	Mod : 20268 = (20268+26999+28495)
0409	Mod : (25205+20268) = (23885+20268) = (26999+20268) = (28382+20268) = (30241+20268) = (26485+20268) = (30631+20268) = (26999+28382+28495+20268) = (25205+26999+28495+20268)
0410	Mod : 25205 = 23885 = 26999 = 28382 = 30241 = 26485 = 30631 = (26999+28382+28495) = (25205+26999+28495)
0411	(CFM Eng. 56-5-B1+20268+31701+25205) = (CFM Eng. 56-5-B1+20268+31701+23885) = (CFM Eng. 56-5-B1+20268+31701+26999) = (CFM Eng. 56-5-B1+20268+31701+28382) = (CFM Eng. 56-5-B1+20268+31701+30241) = (CFM Eng. 56-5-B1+20268+31701+26485) = (CFM Eng. 56-5-B1+20268+31701+30631) = (CFM Eng. 56-5-B1+20268+31701+26999+28382+28495) = (CFM Eng. 56-5-B1+20268+31701+25205+26999+28495) = (CFM Eng. 56-5-B1+20268+34818+25205) = (CFM Eng. 56-5-B1+20268+34818+23885) = (CFM Eng. 56-5-B1+20268+34818+26999) = (CFM Eng. 56-5-B1+20268+34818+28382) = (CFM Eng. 56-5-B1+20268+34818+30241) = (CFM Eng. 56-5-B1+20268+34818+26485) = (CFM Eng. 56-5-B1+20268+34818+30631) = (CFM Eng. 56-5-B1+20268+34818+26999+28382+28495) = (CFM Eng. 56-5-B1+20268+34818+25205+26999+28495) = (CFM Eng. 56-5-B3+20268+25205) = (CFM Eng. 56-5-B3+20268+23885) = (CFM Eng. 56-5-B3+20268+26999) = (CFM Eng. 56-5-B3+20268+28382) = (CFM Eng. 56-5-B3+20268+30241) = (CFM Eng. 56-5-B3+20268+26485) = (CFM Eng. 56-5-B3+20268+30631) = (CFM Eng. 56-5-B3+20268+26999+28382+28495) = (CFM Eng. 56-5-B3+20268+25205+26999+28495)
0412	(CFM Eng. 56-5-B3+20268) = (CFM Eng. 56-5-B1+20268+31701) = (CFM Eng. 56-5-B1+20268+34818) = (CFM Eng. 56-5-B3+20268+26999+28495) = (CFM Eng. 56-5-B1+(20268+31701+26999+28495)=(20268+34818+26999+28495))

CODE	DESIGNATION
0413	Mod : (20343+26526) = (26526+31276) = (20343+26526+27498) = (26526+27498+31276) = (26526+27498+31276+34637)
0419	Mod : (24215+32090) = (24588+32090) = (25534+32090) = (24215+24588+32090) = (24588+25534+32090) (24215+24588+25534+32090) = (24215+28160+28917+32090) = (24588+28160+28917+32090) = (25534+28160+28917+32090) = (24215+24588+28917+32090) = (24215+24588+28160+28917+32090)
0420	Mod : (24215+32090+32499) = (24588+32090+32499) = (25534+32090+32499) = (24215+24588+32090+32499) = (24215+25534+32090+32499) = (24215+24588+25534+32090+32499) = (24215+28160+28917+32090+32499) = (24588+28160+28917+32090+32499) = (25534+28160+28917+32090+32499)
0421	Mod : (22013+24215+32090+32499) = (22013+24588+32090+32499) = (22013+25534+32090+32499) = (24105+24215+32090+32499) = (24105+24588+32090+32499) = (24105+25534+32090+32499) = (28160+24215+32090+32499) = (28160+24588+32090+32499) = (28160+25534+32090+32499) = (22013+24215+24588+32090+32499) = (24105+24215+24588+32090+32499) = (24215+24588+28160+32090+32499)
0422	Mod : STD = (31283+34864) = (31283+34861) = (31283+34862) = (30368+35270) = (30368+35270+31283+34862)
0423	Mod : 30368 = (30368+31283+34861) = (30368+31283+34862) = (30368+31283+34864)
0424	Mod : (24645+28479) = (24645+28702) = (24645+28916) = (24645+31283+34862) = (24645+31283+34861)
0428	Mod : 24771 = (24771+33100+34856) = (24771+33100+34898)
0440	Mod : (20268+21678+25404+28342) = (20268+21678+25404+28342+31106)
0441	Mod : (20268+21678+24946+25404+25647+31106) = (20268+21678+24946+25404+25647+28160+28917+31106)
0445	Mod : (24215+24588+24794) = (24215+24588+24794+32090) = (24215+24588+24794+28160+28917) = (24215+24588+24794+28160+28917+32090) = (24215+24588+24794+28160+28917+32090+31283+34864)
0446	Mod : (22013+24215+24794) = (22013+24215+24588+24794) = (24105+24215+24588+24794) = (24215+24588+24794+28160) = (22013+24215+24588+24794+32090) = (24105+24215+24588+24794+32090) = (24215+24588+24794+28160+32090) = (24215+24588+24794+28160+32090+31283+34861) = (24215+24588+24794+28160+32090+31283+34862) = (22013+24215+24588+24794+32090+31283+34864) = (24105+24215+24588+24794+32090+31283+34862)
0447	Mod : (24215+24588+24794+28378) = (24215+24588+24794+32090+34456) = (24215+24588+24794+28378+32090)
0448	Mod : (22013+24215+24588+24794+30422) = (24215+24588+24794+28160+32090+34456) = (22013+24215+24588+24794+30422+32090) = (24215+24588+24794+28160+28378+32090)
0450	Mod : (22013+24215+24588+24794+26925+31283+32090) = (24105+24215+24588+24794+26965+31283+32090) = (24215+24588+24794+26935+28160+31283+32090)
0454	Mod : (24215+24588+24794+28160+31283) = (24215+24588+24794+28160+31283+32090)

CODE	DESIGNATION
0456	Mod : (20268+24946+26965) = (20268+24946+27773) = (20268+26760+26965) = (20268+26760+27773) = (20268+26965+32150) = (20268+26965+32238) = (20268+26965+32239) = (20268+26965+32311) = (20268+27773+32150) = (20268+27773+32238) = (20268+27773+32239) = (20268+27773+32311) = (20268+26965+27773)
0457	Mod : (20268+24946+26965) = (20268+24946+27773) = (20268+26760+26965) = (20268+26760+27773) = (20268+26965+32150) = (20268+26965+32238) = (20268+26965+32239) = (20268+26965+32311) = (20268+27773+32150) = (20268+27773+32238) = (20268+27773+32239) = (20268+27773+32311)
0458	Mod : (20268+24946+26965) = (20268+24946+27773) = (20268+26760+26965) = (20268+26760+27773) = (20268+26965+32150) = (20268+26965+32238) = (20268+26965+32239) = (20268+26965+32311) = (20268+27773+32150) = (20268+27773+32238) = (20268+27773+32239) = (20268+27773+32311) = (20268+26965+27773+32311)
0459	Mod : 20059 = (20059+31276+32013)
0460	Mod : (20057+20059) = (20057+20059+31276+32013)
0461	Mod : (20057+20343) = (20057+31276) = (20057+20343+31276)
0463	Mod : (20057+20059+20343) = (20057+20059+31276) = (20057+20059+20343+31276)
0466	Mod : 20057 = (20057+31276+32013)

CONTENTS**■ ELEC**

- . ELEC EMER CONFIG-SYS REMAINING 1.01
- . ELEC EMER CONFIG Summary 1.05

■ FIRE

- . SMOKE/FUMES REMOVAL 1.06
- . SMOKE/FUMES/AVNCS SMOKE 1.07

■ HYDRAULIC

- . HYD B+Y SYS LO PR Summary 1.10
- . HYD G+B SYS LO PR Summary 1.11
- . HYD G+Y SYS LO PR Summary 1.12

■ LANDING GEAR

- . LOSS OF BRAKING 1.13

■ NAVIGATION

- . GPWS ALERTS/EGPWS ALERTS ◀ 1.14
- . TCAS WARNINGS ◀ 1.15

■ POWER PLANT

- . ENG DUAL FAILURE – FUEL REMAINING 1.16
- . ENG DUAL FAILURE – NO FUEL REMAINING 1.20

■ MISCELLANEOUS

- . DITCHING 1.23
- . EMER DESCENT 1.25
- . FORCED LANDING 1.24

- R . EMERGENCY EVACUATION 7.00

ELEC EMER CONFIG SYS REMAINING		EMER GEN RUNNING	BAT ONLY	
			IN FLIGHT	ON THE GROUND
AIR COND PRESS	PRESS AUTO SYS 1	Norm	Norm	Norm
	MAN PRESS CTL	Inop	Inop	Inop (1)
	RAM AIR	Norm	Norm	Norm
	PACK VALVE 1	Norm	Closure inop	Closure inop
	PACK VALVE 2	Closure Inop	Closure Inop	Closure Inop (1)
	AVIONIC VENT	Norm	Norm	Partial
APU	ECB – STARTER	Norm (3)	Inop	Inop (1)
	FUEL LP VALVE	Norm	Norm	Norm
	FUEL PUMP	Norm	Norm	Norm
COM	VHF 1	Norm	Norm	Norm
	HF 1	Norm	Inop	Inop
	RMP 1	Norm	Norm	Norm
	ACP (Capt., F / O)	Norm	Norm	Norm
	CIDS	Norm	Norm	Norm
	INTERPHONE	Norm	Norm	Norm
	CVR	Norm	Inop	Inop
	LOUDSPEAKER 1	Norm	Norm	Norm
EIS	PFD 1	Norm	Norm	Norm (2)
	ND 1	Norm	Inop	Inop
	ECAM upper disp.	Norm	Norm	Norm (2)
	DMC 1 or 3	Norm	Norm	Norm (2)
	SDAC 1, FWC 1	Norm	Norm	Norm (2)
	ECAM cont. panel	Norm	Norm	Norm

- (1) Restored, when speed is below 100 knots.
(2) Lost, when speed is below 50 knots.
(3) For APU start only.



CONT'D

ELEC EMER CONFIG SYS REMAINING		EMER GEN RUNNING	BAT ONLY	
			IN FLIGHT	ON THE GROUND
EMER EQPT	CREW OXY	Norm	Norm (4)	Norm (4)
	PAX OXY mask release (auto + man)	Norm	Inop	Inop
	SLIDES ARM/WARN	Norm	Norm	Norm
FLT INS	CLOCKS	Norm	Norm	Norm
FIRE	ENG 1 LOOP	A only	A only	A only
	ENG 2 LOOP	B only	B only	B only
	APU LOOP	Inop	Inop	Inop (1)
	CARGO SMOKE DET	Channel 1	Inop	Inop
	ENG FIRE EXT.	Bottle 1 only	Bottle 1 only	Bottle 1 only
	APU FIRE EXT.	Squib A only	Squib A only	Squib A only
	CARGO FIRE EXT.	Inop	Inop	Inop (1)
	APU AUTO EXT.	Inop	Inop	Inop (1)
FLT CTL	ELAC	N° 1 only	N° 1 + N° 2	N° 1 + N° 2 (3)
	SEC	N° 1 only	N° 1	N° 1 (3)
	FCDC	N° 1 only	Inop	Inop
	SFCC	N° 1 only	N° 1 only	N° 1 only
	Flaps pos ind	Norm	Norm	Norm (2)
FMGS	FMGC (NAV FUNCTION)	N° 1 only	Inop	Inop
	MCDU	N° 1 only	Inop	Inop
	FAC	N° 1 only	Inop	Inop
	FCU	ch 1 only	ch 1 only	ch 1 only
FUEL	LP VALVE	Norm	Norm	Norm
	FQI channel 1	Norm	Inop	Inop
	X FEED VALVE	Norm	Inop	Inop
	TRANSFER VALVE	Norm	Inop	Inop

- (1) Restored, when speed is below 100 knots.
- (2) Lost, when speed is below 50 knots.
- (3) Lost 30 seconds after last engine shutdown.
- (4) Crew oxygen valve control inoperative.



CONT'D

ELEC EMER CONFIG SYS REMAINING		EMER GEN RUNNING	BAT ONLY	
			IN FLIGHT	ON THE GROUND
AIR COND PRESS	PRESS AUTO SYS 1	Norm	Norm	Norm
	MAN PRESS CTL	Inop	Inop	Inop (1)
	RAM AIR	Norm	Norm	Norm
	PACK VALVE 1	Norm	Closure inop	Closure inop
	PACK VALVE 2	Closure Inop	Closure Inop	Closure Inop (1)
	AVIONIC VENT	Norm	Norm	Partial
	AFT CRG VENT VALVES	Norm	Inop	Inop
	AFT CRG HEAT	Norm	Inop	Inop
APU	ECB – STARTER	Norm (3)	Inop	Inop (1)
	FUEL LP VALVE	Norm	Norm	Norm
	FUEL PUMP	Norm	Norm	Norm
COM	VHF 1	Norm	Norm	Norm
	HF 1	Norm	Inop	Inop
	RMP 1	Norm	Norm	Norm
	ACP (Capt., F/O)	Norm	Norm	Norm
	CIDS	Norm	Norm	Norm
	INTERPHONE	Norm	Norm	Norm
	CVR	Norm	Inop	Inop
	LOUDSPEAKER 1	Norm	Norm	Norm
EIS	PFD 1	Norm	Norm	Norm (2)
	ND 1	Norm	Inop	Inop
	ECAM upper disp.	Norm	Norm	Norm (2)
	DMC 1 or 3	Norm	Norm	Norm (2)
	SDAC 1, FWC 1	Norm	Norm	Norm (2)
	ECAM cont. panel	Norm	Norm	Norm

- (1) Restored, when speed is below 100 knots.
(2) Lost, when speed is below 50 knots.
(3) For APU start only.



CONT'D

ELEC EMER CONFIG SYS REMAINING		EMER GEN RUNNING	BAT ONLY	
			IN FLIGHT	ON THE GROUND
EMER EQPT	CREW OXY	Norm	Norm (4)	Norm (4)
	PAX OXY mask release (auto + man)	Norm	Inop	Inop
	SLIDES ARM/WARN	Norm	Norm	Norm
FLT INS	CLOCKS	Norm	Norm	Norm
FIRE	ENG 1 LOOP	A only	A only	A only
	ENG 2 LOOP	B only	B only	B only
	APU LOOP	Inop	Inop	Inop (1)
	CARGO SMOKE DET	Channel 1	Inop	Inop
	ENG FIRE EXT.	Bottle 1 only	Bottle 1 only	Bottle 1 only
	APU FIRE EXT.	Squib A only	Squib A only	Squib A only
	CARGO FIRE EXT.	Inop	Inop	Inop (1)
	APU AUTO EXT.	Inop	Inop	Inop (1)
FLT CTL	ELAC	N° 1 only	N° 1 + N° 2	N° 1 + N° 2 (3)
	SEC	N° 1 only	N° 1	N° 1 (3)
	FCDC	N° 1 only	Inop	Inop
	SFCC	N° 1 only	N° 1 only	N° 1 only
	Flaps pos ind	Norm	Norm	Norm (2)
FMGS	FMGC (NAV FUNCTION)	N° 1 only	Inop	Inop
	MCDU	N° 1 only	Inop	Inop
	FAC	N° 1 only	Inop	Inop
	FCU	ch 1 only	ch 1 only	ch 1 only
FUEL	LP VALVE	Norm	Norm	Norm
	FQI channel 1	Norm	Inop	Inop
	X FEED VALVE	Norm	Inop	Inop
	TRANSFER VALVE	Norm	Inop	Inop

- (1) Restored, when speed is below 100 knots.
- (2) Lost, when speed is below 50 knots.
- (3) Lost 30 seconds after last engine shutdown.
- (4) Crew oxygen valve control inoperative.



CONT'D

ELEC EMER CONFIG SYS REMAINING		EMER GEN RUNNING	BAT ONLY	
			IN FLIGHT	ON THE GROUND
HYD	FIRE VALVES	Norm	Norm	Norm
ICE – RAIN	WING A.ICE	Norm	Inop	Inop
	ENG A.ICE VALVE	Open	Open	Open
	CAPT PITOT	Norm	Norm	Norm (1)
	CAPT AOA	Norm	Inop	Inop
	RAIN REPELLENT (Capt)	Norm	Norm	Norm
L/G	LGCIU SYS 1	Norm	Norm	Norm
	BRK PRESS IND	Norm	Norm	Norm
	PARK BRK	Norm	Norm	Norm
LIGHTS	EMER CKPT	Norm	Norm	Norm
	EMER CAB	Norm	Norm	Norm
NAV	IR	N° 1 only (2)	N° 1 only (2)	N° 1 only (2)
	ADR	N° 1 only	N° 1 only	N° 1 only
	ADF	N° 1 only	Inop	Inop
	VOR-MMR	N° 1 only	N° 1 only	N° 1 only (1)
	DME	N° 1 only	Inop	Inop
	VOR/DDRMI	Norm	Norm	Norm (1)
	ATC	N° 1 only	Inop	Inop
	STBY HORIZON	Norm	Norm	Norm
	STBY COMP (LT)	Norm	Norm	Norm
	STBY ALTI (VIB)	Norm	Inop	Inop

R

- (1) Lost, when speed is below 50 knots.
(2) IR2 and IR3 are lost 5 minutes after failure of the main generators.
But, if IR3 replaces IR1 (ATT-HDG selector at CAPT3), IR3 remains supplied.



CONT'D

ELEC EMER CONFIG SYS REMAINING		EMER GEN RUNNING	BAT ONLY	
			IN FLIGHT	ON THE GROUND
PNEU	ENG 1 BLEED	Norm	BMC 1 inop	BMC 1 inop
	ENG 2 BLEED	BMC 2 inop	BMC 2 inop	BMC 2 inop
	APU BLEED	Inop	Inop	Inop (1)
	X BLEED (man ctl)	Norm	Inop	Inop
PWR	FADEC	A + B (2)	A + B (2)	A + B (2)
	IGNITION	A only	A only	A only
PLT	HP FUEL VALVE closure	Norm	Norm	Norm
MISC	MECH HORN	Norm	Norm	Norm

- (1) Restored, when speed is below 100 knots.
- (2) Channels A and B are self-powered above 10 % N2. If N2 is below 10 %, only Channel A is powered.

ELEC EMER CONFIG SYS REMAINING		EMER GEN RUNNING	BAT ONLY	
			IN FLIGHT	ON THE GROUND
HYD	FIRE VALVES	Norm	Norm	Norm
ICE – RAIN	WING A.ICE	Norm	Inop	Inop
	ENG A.ICE VALVE	Open	Open	Open
	CAPT PITOT	Norm	Norm	Norm (1)
	CAPT AOA	Norm	Inop	Inop
	RAIN REPELLENT (Capt)	Norm	Norm	Norm
L/G	LGCIU SYS 1	Norm	Norm	Norm
	BRK PRESS IND	Norm	Norm	Norm
	PARK BRK	Norm	Norm	Norm
LIGHTS	EMER CKPT	Norm	Norm	Norm
	EMER CAB	Norm	Norm	Norm
NAV	IR	N° 1 only (2)	N° 1 only (2)	N° 1 only (2)
	ADR	N° 1 only	N° 1 only	N° 1 only
	ADF	N° 1 only	Inop	Inop
	VOR-MMR	N° 1 only	N° 1 only	N° 1 only (1)
	DME	N° 1 only	Inop	Inop
	VOR/DDRMI	Norm	Norm	Norm (1)
	ATC	N° 1 only	Inop	Inop
	ISIS	Norm	Norm	Norm

(1) Lost, when speed is below 50 knots.

(2) IR2 and IR3 are lost 5 minutes after failure of the main generators.
But, if IR3 replaces IR1 (ATT-HDG selector at CAPT3), IR3 remains supplied.



CONT'D

ELEC EMER CONFIG SYS REMAINING		EMER GEN RUNNING	BAT ONLY	
			IN FLIGHT	ON THE GROUND
PNEU	ENG 1 BLEED	Norm	BMC 1 inop	BMC 1 inop
	ENG 2 BLEED	BMC 2 inop	BMC 2 inop	BMC 2 inop
	APU BLEED	Inop	Inop	Inop (1)
	X BLEED (man ctl)	Norm	Inop	Inop
PWR	FADEC	A + B (2)	A + B (2)	A + B (2)
	IGNITION	A only	A only	A only
PLT	HP FUEL VALVE closure	Norm	Norm	Norm
MISC	MECH HORN	Norm	Norm	Norm

- (1) Restored, when speed is below 100 knots.
- (2) Channels A and B are self-powered above 10 % N2. If N2 is below 10 %, only Channel A is powered.

ELEC EMER CONFIG SYS REMAINING		EMER GEN RUNNING	BAT ONLY	
			IN FLIGHT	ON THE GROUND
HYD	FIRE VALVES	Norm	Norm	Norm
ICE – RAIN	WING A.ICE	Norm	Inop	Inop
	ENG A.ICE VALVE	Open	Open	Open
	CAPT PITOT	Norm	Norm	Norm (1)
	CAPT AOA	Norm	Inop	Inop
	RAIN REPELLENT (Capt)	Norm	Norm	Norm
L/G	LGCIU SYS 1	Norm	Norm	Norm
	ABCU	Norm	Norm	Norm
	BRK PRESS IND	Norm	Norm	Norm
	PARK BRK	Norm	Norm	Norm
LIGHTS	EMER CKPT	Norm	Norm	Norm
	EMER CAB	Norm	Norm	Norm
NAV	IR	N° 1 only (2)	N° 1 only (2)	N° 1 only (2)
	ADR	N° 1 only	N° 1 only	N° 1 only
	ADF	N° 1 only	Inop	Inop
	VOR-MMR	N° 1 only	N° 1 only	N° 1 only (1)
	DME	N° 1 only	Inop	Inop
	VOR/DDRMI	Norm	Norm	Norm (1)
	ATC	N° 1 only	Inop	Inop
ISIS	Norm	Norm	Norm	

- (1) Lost, when speed is below 50 knots.
(2) IR2 and IR3 are lost 5 minutes after failure of the main generators.
But, if IR3 replaces IR1 (ATT-HDG selector at CAPT3), IR3 remains supplied.



CONT'D

ELEC EMER CONFIG SYS REMAINING		EMER GEN RUNNING	BAT ONLY	
			IN FLIGHT	ON THE GROUND
PNEU	ENG 1 BLEED	Norm	BMC 1 inop	BMC 1 inop
	ENG 2 BLEED	BMC 2 inop	BMC 2 inop	BMC 2 inop
	APU BLEED	Inop	Inop	Inop (1)
	X BLEED (man ctl)	Norm	Inop	Inop
PWR	FADEC	A + B (2)	A + B (2)	A + B (2)
	IGNITION	A only	A only	A only
PLT	HP FUEL VALVE closure	Norm	Norm	Norm
MISC	MECH HORN	Norm	Norm	Norm

- (1) Restored, when speed is below 100 knots.
- (2) Channels A and B are self-powered above 10 % N2. If N2 is below 10 %, only Channel A is powered.

ELEC EMER CONFIG Summary

C R U I S E	MAX SPD 320 KT	
	ALTN LAW : PROT LOST	
	ONLY CAPT PITOT AND AOA HEATED	
	FUEL : CTR TK USABLE BY GRAVITY (2T UNUSABLE).	
	COM : VHF1, ATC1, RMP1 only	
NAV : ILS1, VOR1, GPS1 (if MMR is installed) only		

R R	LANDING CONF	APPROACH SPEED
	Use FLAP 3	VAPP = VREF + 10 KT/140 KT

W(1000 KG)	52	56	60	64	68	72	76	80	84	88	92	94
VREF=VLS CONF FULL	116	121	125	129	133	137	141	144	148	151	155	157

A P P R	CAT 1 ONLY	
	MINIMUM RAT SPEED 140 KT	
	SLATS FLAPS SLOW	
	<ul style="list-style-type: none"> • When L/G down : USE MAN PITCH TRIM. 	

L A N D I N G	FLARE : Only 2 spoilers per wing. Direct law	
	SPOILERS : Only 2 per wing	NO REVERSER
	BRAKING : ALTERNATE without antiskid MAX BRK PR 1000 PSI	
	NO NOSEWHEEL STEERING	

G A	NIL
--------	-----

R R R R R R	ACTUAL LANDING DISTANCES (m) WITH FAILURE										
	WEIGHT (1000 KG)	58	62	66	70	74	78	82	86	90	94
	DRY runway	2010	2090	2190	2280	2380	2500	2650	3170	3390	3610
	WET runway	2160	2280	2410	2550	2680	2820	2970	3190	3400	3570
	CONTA runway	Refer to 4.03 and apply LDG DIST COEF = 2.10									

CORRECTIONS	+ 1000 ft above SL	+ 10 kt tailwind
DRY runway	+ 3 %	+ 16 %
WET runway	+ 4 %	+ 21 %

The method for approach speed computation is given in the QRH 2.31.

SMOKE/FUMES REMOVAL

R

- EMER EXIT LIGHT ON
- If fuel vapors :
 - CAB FANS ON
 - PACK 1+2 OFF
- If no fuel vapors :
 - CAB FANS OFF
 - ECON FLOW OFF
- LDG ELEV 10000 FT/MEA
- DESCENT (FL 100, or MEA, or minimum obstacle clearance altitude) INITIATE
- ATC NOTIFY
- SMOKE/FUMES/
AVNCS SMOKE PROC CONTINUE

While descending, continue applying the appropriate steps of the SMOKE/FUMES/AVNCS SMOKE procedure depending on the suspected smoke source.

- At FL100 or MEA :
 - PACK 1+2 OFF
 - MODE SEL MAN
 - MAN V/S CTL FULL UP
 - RAM AIR ON
- If smoke persists, cockpit window opening :
 - MAX SPEED 200 KT
 - COCKPIT DOOR OPEN
 - HEADSETS ON
 - PNF COCKPIT WINDOW OPEN
- When window is open :
 - NON-AFFECTED PACK(s) ON
 - VISUAL WARNINGS
(noisy CKPT) MONITOR
 - SMOKE/FUMES/
AVNCS SMOKE PROC ... CONTINUE

ELEC EMER CONFIG Summary

C R U I S E	MAX SPD 320 KT	
	ALTN LAW : PROT LOST	
	ONLY CAPT PITOT AND AOA HEATED	
	FUEL : CTR TK UNUSABLE.	
COM : VHF1, ATC1, RMP1 only		
NAV : ILS1, VOR1, GPS1 (if MMR is installed) only		
R	LANDING CONF	APPROACH SPEED
R	Use FLAP 3	VAPP = VREF + 10 KT/140 KT

W(1000 KG)	44	48	52	56	60	64	68	72	76
VREF=VLS CONF FULL	109	112	117	121	125	129	133	137	141

A P P R	CAT 1 ONLY	
	MINIMUM RAT SPEED 140 KT	
	SLATS FLAPS SLOW	
<ul style="list-style-type: none"> • When L/G down : USE MAN PITCH TRIM. 		

L A N D I N G	FLARE : Only 2 spoilers per wing. Direct law	
	SPOILERS : Only 2 per wing	NO REVERSER
	BRAKING : ALTERNATE without antiskid MAX BRK PR 1000 PSI	
	NO NOSEWHEEL STEERING	

G A	NIL
--------	-----

ACTUAL LANDING DISTANCES (m) WITH FAILURE										
WEIGHT (1000 KG)	40	44	48	52	56	60	64	68	72	76
DRY runway	1910	1910	1970	2060	2170	2260	2370	2480	2680	2880
WET runway	1860	1910	1970	2100	2250	2380	2530	2660	2770	2840
CONTA runway	Refer to 4.03 and apply LDG DIST COEF = 2.25									

CORRECTIONS	+ 1000 ft above SL	+ 10 kt tailwind
DRY runway	+ 3 %	+ 19 %
WET runway	+ 4 %	+ 22 %

The method for approach speed computation is given in the QRH 2.31.

SMOKE/FUMES REMOVAL

R

– EMER EXIT LIGHT ON

● If fuel vapors :

– CAB FANS ON

– PACK 1+2 OFF

● If no fuel vapors :

– CAB FANS OFF

– PACK FLOW HI

– LDG ELEV 10000 FT/MEA

– DESCENT (FL 100, or MEA, or minimum obstacle clearance altitude) INITIATE

– ATC NOTIFY

– SMOKE/FUMES/
AVNCS SMOKE PROC CONTINUE

While descending, continue applying the appropriate steps of the SMOKE/FUMES/AVNCS SMOKE procedure depending on the suspected smoke source.

● At FL100 or MEA :

– PACK 1+2 OFF

– MODE SEL MAN

– MAN V/S CTL FULL UP

– RAM AIR ON

● If smoke persists, cockpit window opening :

MAX SPEED 200 KT

– COCKPIT DOOR OPEN

– HEADSETS ON

– PNF COCKPIT WINDOW OPEN

● When window is open :

– NON-AFFECTED PACK(s) ON

– VISUAL WARNINGS

(noisy CKPT) MONITOR

– SMOKE/FUMES/

AVNCS SMOKE PROC ... CONTINUE

ELEC EMER CONFIG Summary

C R U I S E	MAX SPD 320 KT	
	ALTN LAW : PROT LOST	
ONLY CAPT PITOT AND AOA HEATED		
FUEL : CTR TK UNUSABLE.		
COM : VHF1, ATC1, RMP1 only		
NAV : ILS1, VOR1, GPS1 (if MMR is installed) only		
R R	LANDING CONF	APPROACH SPEED
	Use FLAP 3	VAPP = VREF + 10 KT/140 KT

W(1000 KG)	40	44	48	52	56	60	64	68	72	76	78
VREF=VLS CONF FULL	106	111	116	121	125	129	134	138	142	146	147

A P P R	CAT 1 ONLY	
	MINIMUM RAT SPEED 140 KT	
	SLATS FLAPS SLOW	
	AT 1000 FT AGL : LG DOWN	
<ul style="list-style-type: none"> • When L/G down : BATTERIES ONLY. USE MAN PITCH TRIM. 		

L A N D I N G	FLARE : Only 2 spoilers per wing. Direct law	
	SPOILERS : Only 2 per wing	NO REVERSER
	BRAKING : ALTERNATE without antiskid MAX BRK PR 1000 PSI	
	NO NOSEWHEEL STEERING	

R R	G	• When L/G uplocked :
	A	EMER ELEC PWR MAN ON

ACTUAL LANDING DISTANCES (m) WITH FAILURE									
WEIGHT (1000 KG)	46	50	54	58	62	66	70	74	78
DRY runway	1830	1940	2020	2100	2200	2360	2600	2840	3050
WET runway	1830	1950	2070	2220	2360	2500	2650	2790	2910
CONTA runway	Refer to 4.03 and apply LDG DIST COEF = 2.15								

CORRECTIONS	+ 1000 ft above SL	+ 10 kt tailwind
DRY runway	+ 3 %	+ 18 %
WET runway	+ 4 %	+ 21 %

The method for approach speed computation is given in the QRH 2.31.

SMOKE/FUMES REMOVAL

R

– EMER EXIT LIGHT ON

● If fuel vapors :

– CAB FANS ON

– PACK 1+2 OFF

● If no fuel vapors :

– CAB FANS OFF

– PACK FLOW HI

– LDG ELEV 10000 FT/MEA

– DESCENT (FL 100, or MEA, or minimum obstacle clearance altitude) INITIATE

– ATC NOTIFY

– SMOKE/FUMES/
AVNCS SMOKE PROC CONTINUE

While descending, continue applying the appropriate steps of the SMOKE/FUMES/AVNCS SMOKE procedure depending on the suspected smoke source.

● At FL100 or MEA :

– PACK 1+2 OFF

– MODE SEL MAN

– MAN V/S CTL FULL UP

– RAM AIR ON

● If smoke persists, cockpit window opening :

MAX SPEED 200 KT

– COCKPIT DOOR OPEN

– HEADSETS ON

– PNF COCKPIT WINDOW OPEN

● When window is open :

– NON-AFFECTED PACK(s) ON

– VISUAL WARNINGS

(noisy CKPT) MONITOR

– SMOKE/FUMES/
AVNCS SMOKE PROC ... CONTINUE

ELEC EMER CONFIG Summary

C R U I S E	MAX SPD 320 KT	
	ALTN LAW : PROT LOST	
	ONLY CAPT PITOT AND AOA HEATED	
FUEL : CTR TK UNUSABLE.		
COM : VHF1, ATC1, RMP1 only		
NAV : ILS1, VOR1, GPS1 (if MMR is installed) only		
R R	LANDING CONF	APPROACH SPEED
	Use FLAP 3	VAPP = VREF + 10 KT/140 KT

W(1000Kg)	40	44	48	52	56	60	64	68	72	76	78
VREF=VLS CONF FULL	106	111	116	121	125	129	134	138	142	146	147

A P P R	CAT 1 ONLY										
	MINIMUM RAT SPEED 140 KT										
	SLATS FLAPS SLOW										
<ul style="list-style-type: none"> When L/G down : USE MAN PITCH TRIM. 											

L A N D I N G	FLARE : Only 2 spoilers per wing. Direct law										
	SPOILERS : Only 2 per wing					NO REVERSER					
	BRAKING : ALTERNATE without antiskid MAX BRK PR 1000 PSI										
	NO NOSEWHEEL STEERING										

G A	NIL										
--------	-----	--	--	--	--	--	--	--	--	--	--

R R R R R R	ACTUAL LANDING DISTANCES (m) WITH FAILURE										
	WEIGHT (1000 KG)	46	50	54	58	62	66	70	74	78	
	DRY runway	1830	1940	2020	2100	2200	2360	2600	2840	3050	
	WET runway	1830	1950	2070	2220	2360	2500	2650	2790	2910	
	CONTA runway	Refer to 4.03 and apply LDG DIST COEF = 2.15									

CORRECTIONS	+ 1000 ft above SL	+ 10 kt tailwind
DRY runway	+ 3 %	+ 18 %
WET runway	+ 4 %	+ 21 %

The method for approach speed computation is given in the QRH 2.31.

SMOKE/FUMES REMOVAL

R

- EMER EXIT LIGHT ON
- If fuel vapors :
 - CAB FANS ON
 - PACK 1+2 OFF
- If no fuel vapors :
 - CAB FANS OFF
 - PACK FLOW HI
 - LDG ELEV 10000 FT/MEA
 - DESCENT (FL 100, or MEA, or minimum obstacle clearance altitude) INITIATE
 - ATC NOTIFY
 - SMOKE/FUMES/
AVNCS SMOKE PROC CONTINUE

While descending, continue applying the appropriate steps of the SMOKE/FUMES/AVNCS SMOKE procedure depending on the suspected smoke source.
- At FL100 or MEA :
 - PACK 1+2 OFF
 - MODE SEL MAN
 - MAN V/S CTL FULL UP
 - RAM AIR ON
- If smoke persists, cockpit window opening :
 - MAX SPEED 200 KT
 - COCKPIT DOOR OPEN
 - HEADSETS ON
 - PNF COCKPIT WINDOW OPEN
- When window is open :
 - NON-AFFECTED PACK(s) ON
 - VISUAL WARNINGS
(noisy CKPT) MONITOR
 - SMOKE/FUMES/
AVNCS SMOKE PROC ... CONTINUE

SMOKE/FUMES/AVNCS SMOKE**LAND ASAP****IF PERCEPTIBLE SMOKE APPLY IMMEDIATELY :**

- BLOWER OVRD
- EXTRACT OVRD
- CAB FANS OFF
- GALLEY OFF
- SIGNS ON
- CKPT/CABIN COM ESTABLISH

● IF REQUIRED :

- CREW OXY MASKS .. ON/100%/EMERG

● IF SMOKE SOURCE IMMEDIATELY OBVIOUS, ACCESSIBLE, AND EXTINGUISHABLE :

- FAULTY EQPT ISOLATE

● IF SMOKE SOURCE NOT IMMEDIATELY ISOLATED :

- DIVERSION INITIATE
- DESCENT (FL 100 or MEA, or minimum obstacle clearance altitude) INITIATE

● AT ANY TIME of the procedure, if SMOKE/FUMES becomes the GREATEST THREAT :

- SMOKE/FUMES REMOVAL ... CONSIDER
- ELEC EMER CONFIG CONSIDER
Refer to the end of the procedure to set ELEC EMER CONFIG

● At ANY TIME of the procedure, if situation becomes UNMANAGEABLE :

- IMMEDIATE LANDING CONSIDER



SMOKE/FUMES/AVNCS SMOKE (CONT'D)

R

● **IF AIR COND SMOKE SUSPECTED :**

- APU BLEED OFF
- BLOWER AUTO
- EXTRACT AUTO
- PACK 1 OFF

● **If smoke continues :**

- PACK 1 ON
- PACK 2 OFF
- CRG AFT ISOL VALVE OFF

● **If smoke still continues :**

- PACK 2 ON
- BLOWER OVRD
- EXTRACT OVRD
- SMOKE/FUMES REMOVAL . CONSIDER

R

● **IF CAB EQUIPMENT SMOKE SUSPECTED:**● **If smoke continues :**

- EMER EXIT LIGHT ON
- BUS TIE OFF
- GEN 2 OFF
- SMOKE DISSIPATION CHECK
- FAULTY EQPT SEARCH/ISOLATE

● **If smoke still continues or if faulty equipment confirmed isolated :**

- GEN 2 ON
- BUS TIE AUTO

● **If faulty equipment not confirmed isolated, before L/G extension :**

- GEN 2 ON
- BUS TIE AUTO
- SMOKE/FUMES REMOVAL . CONSIDER



SMOKE/FUMES/AVNCS SMOKE**LAND ASAP****IF PERCEPTIBLE SMOKE APPLY IMMEDIATELY :**

- BLOWER OVRD
- EXTRACT OVRD
- CAB FANS OFF
- GALY & CAB OFF
- SIGNS ON
- CKPT/CAB COM ESTABLISH

● IF REQUIRED :

- CREW OXY MASKS .. ON/100%/EMERG

● IF SMOKE SOURCE IMMEDIATELY OBVIOUS, ACCESSIBLE, AND EXTINGUISHABLE :

- FAULTY EQPT ISOLATE

● IF SMOKE SOURCE NOT IMMEDIATELY ISOLATED :

- DIVERSION INITIATE
- DESCENT (FL 100, or MEA, or minimum obstacle clearance altitude) INITIATE

● AT ANY TIME of the procedure, if SMOKE/FUMES becomes the GREATEST THREAT :

- SMOKE/FUMES REMOVAL ... CONSIDER
- ELEC EMER CONFIG CONSIDER
Refer to the end of the procedure to set ELEC EMER CONFIG

● At ANY TIME of the procedure, if situation becomes UNMANAGEABLE :

- IMMEDIATE LANDING CONSIDER



SMOKE/FUMES/AVNCS SMOKE (CONT'D)

R

● **IF AIR COND SMOKE SUSPECTED :**

- APU BLEED OFF
- BLOWER AUTO
- EXTRACT AUTO
- PACK 1 OFF

● **If smoke continues :**

- PACK 1 ON
- PACK 2 OFF

● **If smoke still continues :**

- PACK 2 ON
- BLOWER OVRD
- EXTRACT OVRD
- SMOKE/FUMES REMOVAL . CONSIDER

R

● **IF CAB EQUIPMENT SMOKE SUSPECTED:**● **If smoke continues :**

- EMER EXIT LIGHT ON
- COMMERCIAL OFF
- SMOKE DISSIPATION CHECK
- FAULTY EQPT SEARCH/ISOLATE

● **If smoke still continues or if faulty equipment confirmed isolated :**

- COMMERCIAL NORM
- SMOKE/FUMES REMOVAL . CONSIDER



SMOKE/FUMES/AVNCS SMOKE**LAND ASAP****IF PERCEPTIBLE SMOKE APPLY IMMEDIATELY :**

- BLOWER OVRD
- EXTRACT OVRD
- CAB FANS OFF
- GALY & CAB OFF
- SIGNS ON
- CKPT/CAB COM ESTABLISH

● IF REQUIRED :

- CREW OXY MASKS .. ON/100%/EMERG

● IF SMOKE SOURCE IMMEDIATELY OBVIOUS, ACCESSIBLE, AND EXTINGUISHABLE :

- FAULTY EQPT ISOLATE

● IF SMOKE SOURCE NOT IMMEDIATELY ISOLATED :

- DIVERSION INITIATE
- DESCENT (FL 100, or MEA, or minimum obstacle clearance altitude) INITIATE

● AT ANY TIME of the procedure, if SMOKE/FUMES becomes the GREATEST THREAT :

- SMOKE/FUMES REMOVAL ... CONSIDER
- ELEC EMER CONFIG CONSIDER
Refer to the end of the procedure to set ELEC EMER CONFIG

● At ANY TIME of the procedure, if situation becomes UNMANAGEABLE :

- IMMEDIATE LANDING CONSIDER



SMOKE/FUMES/AVNCS SMOKE (CONT'D)

R

● **IF AIR COND SMOKE SUSPECTED :**

- APU BLEED OFF
- BLOWER AUTO
- EXTRACT AUTO
- PACK 1 OFF

● **If smoke continues :**

- PACK 1 ON
- PACK 2 OFF
- CRG AFT ISOL VALVE OFF

● **If smoke still continues :**

- PACK 2 ON
- BLOWER OVRD
- EXTRACT OVRD
- SMOKE/FUMES REMOVAL . CONSIDER

R

● **IF CAB EQUIPMENT SMOKE SUSPECTED:**● **If smoke continues :**

- EMER EXIT LIGHT ON
- BUS TIE OFF
- GEN 2 OFF
- SMOKE DISSIPATION CHECK
- FAULTY EQPT SEARCH/ISOLATE

● **If smoke still continues or if faulty equipment confirmed isolated :**

- GEN 2 ON
- BUS TIE AUTO

● **If faulty equipment not confirmed isolated, before L/G extension :**

- GEN 2 ON
- BUS TIE AUTO
- SMOKE/FUMES REMOVAL . CONSIDER



SMOKE/FUMES/AVNCS SMOKE**LAND ASAP****IF PERCEPTIBLE SMOKE APPLY IMMEDIATELY :**

- BLOWER OVRD
- EXTRACT OVRD
- CAB FANS OFF
- GALY & CAB OFF
- SIGNS ON
- CKPT/CAB COM ESTABLISH

● IF REQUIRED :

- CREW OXY MASKS .. ON/100%/EMERG

● IF SMOKE SOURCE IMMEDIATELY OBVIOUS, ACCESSIBLE, AND EXTINGUISHABLE :

- FAULTY EQPT ISOLATE

● IF SMOKE SOURCE NOT IMMEDIATELY ISOLATED :

- DIVERSION INITIATE
- DESCENT (FL 100, or MEA, or minimum obstacle clearance altitude) INITIATE

● AT ANY TIME of the procedure, if SMOKE/FUMES becomes the GREATEST THREAT :

- SMOKE/FUMES REMOVAL ... CONSIDER
- ELEC EMER CONFIG CONSIDER
Refer to the end of the procedure to set ELEC EMER CONFIG

● At ANY TIME of the procedure, if situation becomes UNMANAGEABLE :

- IMMEDIATE LANDING CONSIDER



SMOKE/FUMES/AVNCS SMOKE (CONT'D)

R

● **IF AIR COND SMOKE SUSPECTED :**

- APU BLEED OFF
- BLOWER AUTO
- EXTRACT AUTO
- PACK 1 OFF

● **If smoke continues :**

- PACK 1 ON
- PACK 2 OFF
- CRG AFT ISOL VALVE OFF

● **If smoke still continues :**

- PACK 2 ON
- BLOWER OVRD
- EXTRACT OVRD
- SMOKE/FUMES REMOVAL . CONSIDER

R

● **IF CAB EQUIPMENT SMOKE SUSPECTED:**● **If smoke continues :**

- EMER EXIT LIGHT ON
- COMMERCIAL OFF
- SMOKE DISSIPATION CHECK
- FAULTY EQPT SEARCH/ISOLATE

● **If smoke still continues or if faulty equipment confirmed isolated :**

- COMMERCIAL NORM
- SMOKE/FUMES REMOVAL . CONSIDER



SMOKE/FUMES/AVNCS SMOKE (CONT'D)

● **IF SMOKE SOURCE CANNOT BE DETERMINED AND STILL CONTINUES OR AVNCS/ELECTRICAL SMOKE SUSPECTED :**

● **Shed AC BUS 1 as follows :**

- GEN 2 CHECK ON
- ELEC page SELECT
- BUS TIE OFF
- AC ESS FEED ALTN
- GEN 1 OFF
- SMOKE DISSIPATION CHECK

● **If smoke continues :**

- GEN 1 ON
- AC ESS FEED NORM

● **Shed AC BUS 2 as follows :**

- GEN 1 CHECK ON
- ELEC PAGE SELECT
- AC ESS FEED CHECK NORM
- BUS TIE CHECK OFF
- GEN 2 OFF
- SMOKE DISSIPATION CHECK

● **If smoke continues :**

- GEN 2 ON
- BUS TIE AUTO
- SMOKE/FUMES REMOVAL ... CONSIDER
- ELEC EMER CONFIG CONSIDER



R

R

SMOKE/FUMES/AVNCS SMOKE (CONT'D)

**● IF SMOKE DISAPPEARS WITHIN
5 MINUTES :**

– NORMAL VENTILATION RESTORE

TO SET ELEC EMER CONFIG

– EMER ELEC GEN 1 LINE OFF

– EMER ELEC PWR MAN ON

● WHEN EMER GEN AVAIL :

– APU GEN OFF

– GEN 2 OFF

ELEC EMER CONFIG

– APPLY ECAM PROCEDURE

– IF AVIONICS SMOKE ECAM NOT
TRIGGERED DO NOT PERFORM THE GEN
RESET

R

HYD B + Y SYS LO PR Summary

C R U I S E	MAX SPD 320/.77	
	MANEUVER WITH CARE Flight controls remain in normal law.	
	LANDING CONF	APPROACH SPEED
	Use FLAP 3	VAPP = VREF + 10 kt

W(1000 KG)	52	56	60	64	68	72	76	80	84	88	92	94
VREF=VLS CONF FULL	116	121	125	129	133	137	141	144	148	151	155	157

A P P R	SLATS SLOW / FLAPS SLOW		CAT 1 ONLY
	GPWS LDG FLAP 3 ON		
	L/G GRAVITY EXTENSION		

L A N D I N G	FLARE : Only one ELEV and two spoilers per wing.	
	SPOILERS : Only 2 per wing	REVERSER : Only N°1
	BRAKING : NORMAL	
	NO NOSEWHEEL STEERING	

G A	NO GEAR RETRACTION. Increased fuel consumption
--------	--

ACTUAL LANDING DISTANCES (m) WITH FAILURE										
WEIGHT (1000 KG)	58	62	66	70	74	78	82	86	90	94
DRY runway	1440	1490	1560	1630	1700	1790	1890	2260	2420	2580
WET runway	1870	1980	2090	2210	2320	2440	2570	2770	2950	3090
CONTA runway	Refer to 4.03 and apply LDG DIST COEF = 1.85									

CORRECTIONS	+ 1000 ft above SL	+ 10 kt tailwind
DRY runway	+ 3 %	+ 16 %
WET runway	+ 4 %	+ 21 %

The method for approach speed computation is given in the QRH 2.31.

HYD B + Y SYS LO PR Summary

C R U I S E	MAX SPD 320/.77	
	MANEUVER WITH CARE Flight controls remain in normal law.	
	LANDING CONF	APPROACH SPEED
	NORM	VAPP CONF FULL (or CONF 3) (No ΔVREF)

W(1000 KG)	44	48	52	56	60	64	68	72	76
VREF=VLS CONF FULL	109	112	117	121	125	129	133	137	141
VLS CONF 3	115	120	125	130	134	139	143	147	151

A P P R	SLATS SLOW / FLAPS SLOW	CAT 1 ONLY
	L/G GRAVITY EXTENSION	

L A N D I N G	FLARE : Only one ELEV and two spoilers per wing.	
	SPOILERS : Only 2 per wing	REVERSER : Only N°1
	BRAKING : NORMAL	
	NO NOSEWHEEL STEERING	

G A	NO GEAR RETRACTION. Increased fuel consumption
--------	--

	ACTUAL LANDING DISTANCES (m) WITH FAILURE									
WEIGHT (1000 KG)	40	44	48	52	56	60	64	68	72	76
DRY runway (Conf full)	1180	1180	1210	1260	1330	1390	1460	1530	1650	1770
DRY runway (Conf 3)	1380	1380	1420	1480	1560	1620	1710	1790	1930	2080
WET runway (Conf full)	1510	1540	1600	1700	1820	1930	2050	2160	2240	2290
WET runway (Conf 3)	1750	1790	1850	1970	2110	2230	2370	2490	2600	2660
CONTA runway (Conf full)	Refer to 4.03 and apply LDG DIST COEF = 1.85									
CONTA runway (Conf 3)	Refer to 4.03 and apply LDG DIST COEF = 2.15									

CORRECTIONS	+ 1000 ft above SL	+ 10 kt tailwind
DRY runway	+ 3 %	+ 19 %
WET runway	+ 4 %	+ 22 %

The method for approach speed computation is given in the QRH 2.31.

HYD B + Y SYS LO PR Summary

C R U I S E	MAX SPD 320/.77	
	MANEUVER WITH CARE Flight controls remain in normal law.	
	LANDING CONF	APPROACH SPEED
	NORM	VAPP CONF FULL (or CONF 3) (No ΔVREF)

W(1000 KG)	40	44	48	52	56	60	64	68	72	76	78
VREF=VLS CONF FULL	106	111	116	121	125	129	134	138	142	146	147
VLS CONF 3	109	114	119	124	128	133	137	142	146	150	152

A P P R	SLATS SLOW / FLAPS SLOW	CAT 1 ONLY
	L/G GRAVITY EXTENSION	

L A N D I N G	FLARE : Only one ELEV and two spoilers per wing.	
	SPOILERS : Only 2 per wing	REVERSER : Only N°1
	BRAKING : NORMAL	
	NO NOSEWHEEL STEERING	

G A	NO GEAR RETRACTION. Increased fuel consumption
--------	--

	ACTUAL LANDING DISTANCES (m) WITH FAILURE									
WEIGHT (1000 KG)	46	50	54	58	62	66	70	74	78	
DRY runway (Conf full)	1180	1250	1300	1350	1420	1520	1670	1820	1960	
DRY runway (Conf 3)	1320	1390	1450	1510	1580	1700	1870	2040	2190	
WET runway (Conf full)	1510	1610	1710	1830	1950	2070	2190	2300	2410	
WET runway (Conf 3)	1670	1780	1890	2020	2150	2290	2420	2550	2660	
CONTA runway (Conf full)	Refer to 4.03 and apply LDG DIST COEF = 1.85									
CONTA runway (Conf 3)	Refer to 4.03 and apply LDG DIST COEF = 2.05									

CORRECTIONS	+ 1000 ft above SL	+ 10 kt tailwind
DRY runway	+ 3 %	+ 18 %
WET runway	+ 4 %	+ 21 %

The method for approach speed computation is given in the QRH 2.31.

HYD G + B SYS LO PR Summary

C R U I S E	SPD BRK DO NOT USE	
	MAX SPD 320/.77	
	MANEUVER WITH CARE ALTN LAW : PROT LOST	
R R	LANDING CONF	APPROACH SPEED
	Use FLAP 3	VAPP = VREF + 25 KT

W (1000 KG)	52	56	60	64	68	72	76	80	84	88	92	94
VREF=VLS CONF FULL	116	121	125	129	133	137	141	144	148	151	155	157

R R A P P R	SLATS JAMMED / FLAPS SLOW	CAT 1 ONLY
	ATHR	OFF
	GPWS LDG FLAP 3	ON
	<ul style="list-style-type: none"> WHEN SPD 200 KT - L/G GRVTY EXTN WHEN L/G down : USE MAN PITCH TRIM 	
For Flaps extension : SPD SEL		VFE NEXT – 5KT
When in landing CONF : DECELERATE TO CALCULATED VAPP		

L A N D I N G	FLARE : Only one ELEV and two spoilers per wing. No ailerons. A/C slightly sluggish – Direct law	
	SPOILERS : Only 2 per wing	REVERSER : Only N°2
	BRAKING : ALTERNATE	
	NO NOSEWHEEL STEERING	

G O A R O U N D	NO GEAR RETRACTION. Increased fuel consumption	
	<ul style="list-style-type: none"> For circuit : MAINTAIN SLATS/FLAPS CONFIGURATION Recommended speed : MAX SPD – 10 KT 	
	<ul style="list-style-type: none"> For diversion : SELECT CLEAN CONFIGURATION If Slats at zero : Normal operating speeds If Slats not at zero : Recommended speed MAX SPD – 10 KT 	

ACTUAL LANDING DISTANCES (m) WITH FAILURE										
WEIGHT (1000 KG)	58	62	66	70	74	78	82	86	90	94
DRY runway	1520	1580	1650	1730	1800	1890	2000	2390	2560	2720
WET runway	1970	2080	2190	2320	2440	2570	2700	2910	3100	3250
CONTA runway	Refer to 4.03 and apply LDG DIST COEF = 1.90									

CORRECTIONS	+ 1000 ft above SL	+ 10 kt tailwind
DRY runway	+ 3 %	+ 16 %
WET runway	+ 4 %	+ 21 %

The method for approach speed computation is given in the QRH 2.31.

HYD G + Y SYS LO PR Summary

C R U I S E	MAX SPD 320/.77	
	MANEUVER WITH CARE	
	ALTN LAW : PROT LOST	
	LANDING CONF	APPROACH SPEED
	Use FLAP 3	VAPP = VREF + 30 KT

W (1000 KG)	52	56	60	64	68	72	76	80	84	88	92	94
VREF = VLS CONF FULL	116	121	125	129	133	137	141	144	148	151	155	157

A P P R	SLATS SLOW / FLAPS JAMMED CAT 1 ONLY	
	GPWS FLAP MODE OFF	
	For Flaps extension : SPD SEL VFE NEXT – 5KT When in landing CONF : DECELERATE TO CALCULATED VAPP Stabilize at VAPP before L/G down, to be trimmed for approach. L/G GRAVITY EXTENSION	

L A N D I N G	FLARE : PITCH AUTHORITY REDUCED (No stabilizer). MAN TRIM Unusable Only 1 spoiler per wing – Direct law	
	SPOILERS : Only 1 per wing	NO REVERSER
	BRAKING : BRK Y ACCU PR ONLY (7 applications) MAX BRK PR 1000 PSI	
	NO NOSEWHEEL STEERING	

G O A R O U N D	NO GEAR RETRACTION. Increased fuel consumption	
	● For circuit : MAINTAIN SLATS/FLAPS CONFIGURATION Recommended speed : MAX SPD – 10 KT	
	● For diversion :	
	● If Flaps at zero : SELECT CLEAN CONFIGURATION Normal operating speeds ● If Flaps not at zero : MAINTAIN SLATS/FLAPS CONFIG Recommended speed : MAX SPD – 10 KT	

	ACTUAL LANDING DISTANCES (m) WITH FAILURE										
WEIGHT (1000 KG)	58	62	66	70	74	78	82	86	90	94	
DRY runway	2050	2130	2230	2330	2430	2550	2700	3230	3450	3680	
WET runway	2250	2380	2510	2660	2790	2950	3100	3330	3550	3720	
CONTA runway	Refer to 4.03 and apply LDG DIST COEF = 2.40										

CORRECTIONS	+ 1000 ft above SL	+ 10 kt tailwind
DRY runway	+ 3 %	+ 16 %
WET runway	+ 4 %	+ 21 %

The method for approach speed computation is given in the QRH 2.31.

HYD G + B SYS LO PR Summary

C R U I S E	SPD BRK DO NOT USE	
	MAX SPD 320/.77	
	MANEUVER WITH CARE ALTN LAW : PROT LOST	
	LANDING CONF	APPROACH SPEED
	Use FLAP 3	VAPP = VREF + 25 KT

W (1000 KG)	44	48	52	56	60	64	68	72	76
VREF=VLS CONF FULL	109	112	117	121	125	129	133	137	141

A P P R	SLATS JAMMED / FLAPS SLOW	CAT 1 ONLY
	ATHR	OFF
	GPWS LDG FLAP 3	ON
	<ul style="list-style-type: none"> WHEN SPD 200 KT - L/G GRVTY EXTN 	
	<ul style="list-style-type: none"> WHEN L/G down : USE MAN PITCH TRIM 	
	For Flaps extension : SPD SEL VFE NEXT - 5KT	
	When in landing CONF : DECELERATE TO CALCULATED VAPP	

L A N D I N G	FLARE : Only one ELEV and two spoilers per wing. No ailerons. A/C slightly sluggish - Direct law
	SPOILERS : Only 2 per wing REVERSER : Only N°2
	BRAKING : ALTERNATE
	NO NOSEWHEEL STEERING

G O A R O U N D	NO GEAR RETRACTION. Increased fuel consumption
	<ul style="list-style-type: none"> For circuit : MAINTAIN SLATS/FLAPS CONFIGURATION Recommended speed : MAX SPD - 10 KT
	<ul style="list-style-type: none"> For diversion : SELECT CLEAN CONFIGURATION If Slats at zero : Normal operating speeds If Slats not at zero : Recommended speed MAX SPD - 10 KT

ACTUAL LANDING DISTANCES (m) WITH FAILURE										
WEIGHT (1000 KG)	40	44	48	52	56	60	64	68	72	76
DRY runway	1210	1210	1250	1300	1370	1430	1500	1570	1700	1820
WET runway	1630	1660	1720	1830	1970	2080	2210	2320	2420	2480
CONTA runway	Refer to 4.03 and apply LDG DIST COEF = 2.00									

CORRECTIONS	+ 1000 ft above SL	+ 10 kt tailwind
DRY runway	+ 3 %	+ 19 %
WET runway	+ 4 %	+ 22 %

The method for approach speed computation is given in the QRH 2.31.

HYD G + Y SYS LO PR Summary

C R U I S E	MAX SPD 320/.77	
	MANEUVER WITH CARE	
	ALTN LAW : PROT LOST	
	LANDING CONF	APPROACH SPEED
	Use FLAP 3	VAPP = VREF + 25 KT

W (1000 KG)	44	48	52	56	60	64	68	72	76
VREF = VLS CONF FULL	109	112	117	121	125	129	133	137	141

A P P R	SLATS SLOW / FLAPS JAMMED CAT 1 ONLY	
	GPWS FLAP MODE OFF	
	For Flaps extension : SPD SEL VFE NEXT – 5KT When in landing CONF : DECELERATE TO CALCULATED VAPP Stabilize at VAPP before L/G down, to be trimmed for approach. L/G GRAVITY EXTENSION	

L A N D I N G	FLARE : PITCH AUTHORITY REDUCED (No stabilizer). MAN TRIM Unusable Only 1 spoiler per wing – Direct law	
	SPOILERS : Only 1 per wing	NO REVERSER
	BRAKING : BRK Y ACCU PR ONLY (7 applications) MAX BRK PR 1000 PSI	
	NO NOSEWHEEL STEERING	

G O A R O U N D	NO GEAR RETRACTION. Increased fuel consumption	
	● For circuit : MAINTAIN SLATS/FLAPS CONFIGURATION Recommended speed : MAX SPD – 10 KT	
	● For diversion :	
	<ul style="list-style-type: none"> ● If Flaps at zero : SELECT CLEAN CONFIGURATION Normal operating speeds ● If Flaps not at zero : MAINTAIN SLATS/FLAPS CONFIG Recommended speed : MAX SPD – 10 KT 	

	ACTUAL LANDING DISTANCES (m) WITH FAILURE									
WEIGHT (1000 KG)	40	44	48	52	56	60	64	68	72	76
DRY runway	1880	1880	1940	2020	2130	2220	2330	2440	2640	2830
WET runway	1860	1910	1970	2100	2250	2380	2530	2660	2770	2840
CONTA runway	Refer to 4.03 and apply LDG DIST COEF = 2.40									

CORRECTIONS	+ 1000 ft above SL	+ 10 kt tailwind
DRY runway	+ 3 %	+ 19 %
WET runway	+ 4 %	+ 22 %

The method for approach speed computation is given in the QRH 2.31.

HYD G + B SYS LO PR Summary

C R U I S E	SPD BRK DO NOT USE	
	MAX SPD 320/.77	
	MANEUVER WITH CARE ALTN LAW : PROT LOST	
	LANDING CONF	APPROACH SPEED
	Use FLAP 3	VAPP = VREF + 25 KT

W (1000 KG)	40	44	48	52	56	60	64	68	72	76	78
VREF=VLS CONF FULL	106	111	116	121	125	129	134	138	142	146	147

A P P R	SLATS JAMMED / FLAPS SLOW	CAT 1 ONLY
	ATHR	OFF
	GPWS LDG FLAP 3	ON
	● WHEN SPD 200 KT - L/G	GRVTY EXTN
	● WHEN L/G down : USE MAN PITCH TRIM	
	For Flaps extension : SPD SEL	VFE NEXT - 5KT
	When in landing CONF : DECELERATE TO CALCULATED VAPP	

L A N D I N G	FLARE : Only one ELEV and two spoilers per wing. No ailerons. A/C slightly sluggish - Direct law
	SPOILERS : Only 2 per wing REVERSER : Only N°2
	BRAKING : ALTERNATE
	NO NOSEWHEEL STEERING

G O A R O U N D	NO GEAR RETRACTION. Increased fuel consumption
	● For circuit : MAINTAIN SLATS/FLAPS CONFIGURATION Recommended speed : MAX SPD - 10 KT
	● For diversion : SELECT CLEAN CONFIGURATION If Slats at zero : Normal operating speeds If Slats not at zero : Recommended speed MAX SPD - 10 KT

ACTUAL LANDING DISTANCES (m) WITH FAILURE										
WEIGHT (1000 KG)	46	50	54	58	62	66	70	74	78	
DRY runway	1250	1320	1370	1430	1500	1610	1770	1930	2070	
WET runway	1590	1700	1800	1930	2050	2180	2300	2430	2530	
CONTA runway	Refer to 4.03 and apply LDG DIST COEF = 1.95									

CORRECTIONS	+ 1000 ft above SL	+ 10 kt tailwind
DRY runway	+ 3 %	+ 18 %
WET runway	+ 4 %	+ 21 %

The method for approach speed computation is given in the QRH 2.31.

HYD G + Y SYS LO PR Summary

C R U I S E	MAX SPD 320/.77	
	MANEUVER WITH CARE	
	ALTN LAW : PROT LOST	
	LANDING CONF	APPROACH SPEED
	Use FLAP 3	VAPP = VREF + 25 KT

W (1000 KG)	40	44	48	52	56	60	64	68	72	76	78
VREF = VLS CONF FULL	106	111	116	121	125	129	134	138	142	146	147

A P P R	SLATS SLOW / FLAPS JAMMED CAT 1 ONLY
	GPWS FLAP MODE OFF
	For Flaps extension : SPD SEL VFE NEXT – 5KT
	When in landing CONF : DECELERATE TO CALCULATED VAPP
	Stabilize at VAPP before L/G down, to be trimmed for approach.
	L/G GRAVITY EXTENSION

L A N D I N G	FLARE : PITCH AUTHORITY REDUCED (No stabilizer). MAN TRIM Unusable Only 1 spoiler per wing – Direct law
	SPOILERS : Only 1 per wing NO REVERSER
	BRAKING : BRK Y ACCU PR ONLY (7 applications) MAX BRK PR 1000 PSI
	NO NOSEWHEEL STEERING

G O A R O U N D	NO GEAR RETRACTION. Increased fuel consumption
	● For circuit : MAINTAIN SLATS/FLAPS CONFIGURATION Recommended speed : MAX SPD – 10 KT
	● For diversion :
	● If Flaps at zero : SELECT CLEAN CONFIGURATION Normal operating speeds
	● If Flaps not at zero : MAINTAIN SLATS/FLAPS CONFIG Recommended speed : MAX SPD – 10 KT

	ACTUAL LANDING DISTANCES (m) WITH FAILURE									
WEIGHT (1000 KG)	46	50	54	58	62	66	70	74	78	
DRY runway	1940	2050	2130	2220	2330	2500	2750	3000	3220	
WET runway	1950	2080	2210	2360	2510	2670	2820	2970	3100	
CONTA runway	Refer to 4.03 and apply LDG DIST COEF = 2.45									

CORRECTIONS	+ 1000 ft above SL	+ 10 kt tailwind
DRY runway	+ 3 %	+ 18 %
WET runway	+ 4 %	+ 21 %

The method for approach speed computation is given in the QRH 2.31.

HYD G + B SYS LO PR Summary

C R U I S E	SPD BRK	DO NOT USE
	MAX SPD	320/.77
	MANEUVER WITH CARE	
	ALTN LAW : PROT LOST	
R R	LANDING CONF	APPROACH SPEED
	Use FLAP 3	VAPP = VREF + 25 KT

W (1000 KG)	40	44	48	52	56	60	64	68	72	76	78
VREF=VLS CONF FULL	106	111	116	121	125	129	134	138	142	146	147

R R	SLATS JAMMED / FLAPS SLOW	CAT 1 ONLY
	ATHR	OFF
	GPWS LDG FLAP 3	ON
	● WHEN SPD 200 KT	
	- L/G	GRVTY EXTN
	● WHEN L/G down : USE MAN PITCH TRIM	
	For Flaps extension : SPD SEL	VFE NEXT - 5KT
	When in landing CONF : DECELERATE TO CALCULATED VAPP	

L A N D I N G	FLARE : Only one ELEV and two spoilers per wing. No ailerons. A/C slightly sluggish - Direct law
	SPOILERS : Only 2 per wing REVERSER : Only N°2
	BRAKING : ALTERNATE

G O A R O U N D	NO GEAR RETRACTION. Increased fuel consumption
	● For circuit : MAINTAIN SLATS/FLAPS CONFIGURATION Recommended speed : MAX SPD - 10 KT
	● For diversion : SELECT CLEAN CONFIGURATION If Slats at zero : Normal operating speeds If Slats not at zero : Recommended speed MAX SPD - 10 KT

ACTUAL LANDING DISTANCES (m) WITH FAILURE										
WEIGHT (1000 KG)	46	50	54	58	62	66	70	74	78	
DRY runway	1250	1320	1370	1430	1500	1610	1770	1930	2070	
WET runway	1590	1700	1800	1930	2050	2180	2300	2430	2530	
CONTA runway	Refer to 4.03 and apply LDG DIST COEF = 1.95									

CORRECTIONS	+ 1000 ft above SL	+ 10 kt tailwind
DRY runway	+ 3 %	+ 18 %
WET runway	+ 4 %	+ 21 %

The method for approach speed computation is given in the QRH 2.31.

HYD G + Y SYS LO PR Summary

C R U I S E	MAX SPD 320/.77	
	MANEUVER WITH CARE	
	ALTN LAW : PROT LOST	
	LANDING CONF	APPROACH SPEED
	Use FLAP 3	VAPP = VREF + 25 KT

W (1000 KG)	40	44	48	52	56	60	64	68	72	76	78
VREF = VLS CONF FULL	106	111	116	121	125	129	134	138	142	146	147

A P P R	SLATS SLOW / FLAPS JAMMED CAT 1 ONLY	
	GPWS FLAP MODE OFF	
For Flaps extension : SPD SEL VFE NEXT – 5KT		
When in landing CONF : DECELERATE TO CALCULATED VAPP		
Stabilize at VAPP before L/G down, to be trimmed for approach.		
L/G GRAVITY EXTENSION		

L A N D I N G	FLARE : PITCH AUTHORITY REDUCED (No stabilizer). MAN TRIM Unusable Only 1 spoiler per wing – Direct law	
	SPOILERS : Only 1 per wing	NO REVERSER
	BRAKING : BRK Y ACCU PR ONLY (7 applications) MAX BRK PR 1000 PSI	
	NO NOSEWHEEL STEERING	

G O A R O U N D	NO GEAR RETRACTION. Increased fuel consumption	
	● For circuit : MAINTAIN SLATS/FLAPS CONFIGURATION Recommended speed : MAX SPD – 10 KT	
	● For diversion :	
	● If Flaps at zero : SELECT CLEAN CONFIGURATION Normal operating speeds	
● If Flaps not at zero : MAINTAIN SLATS/FLAPS CONFIG Recommended speed : MAX SPD – 10 KT		

ACTUAL LANDING DISTANCES (m) WITH FAILURE										
WEIGHT (1000 KG)	46	50	54	58	62	66	70	74	78	
DRY runway	1940	2050	2130	2220	2330	2500	2750	3000	3220	
WET runway	1950	2080	2210	2360	2510	2670	2820	2970	3100	
CONTA runway	Refer to 4.03 and apply LDG DIST COEF = 2.45									

CORRECTIONS	+ 1000 ft above SL	+ 10 kt tailwind
DRY runway	+ 3 %	+ 18 %
WET runway	+ 4 %	+ 21 %

The method for approach speed computation is given in the QRH 2.31.

LOSS OF BRAKING

- IF AUTOBRAKE IS SELECTED :
 - BRAKE PEDALS PRESS
- IF NO BRAKING AVAILABLE :
 - REV MAX
 - BRAKE PEDALS RELEASE
 - A/SKID & N/W STRG OFF
 - BRAKE PEDALS PRESS
 - MAX BRK PR 1000 PSI
- If STILL NO BRAKING :
 - PARKING BRAKE SHORT AND SUCCESSIVE APPLICATIONS

EGPWS ALERTS

CAUTION

During night or IMC conditions, apply the procedure immediately. Do not delay reaction for diagnosis.

During daylight VMC conditions, with terrain and obstacles clearly in sight, the alert may be considered cautionary. Take positive corrective action until the alert stops or a safe trajectory is ensured.

■ **"PULL UP" – "TERRAIN TERRAIN PULL UP" – "TERRAIN AHEAD PULL UP"**

Simultaneously :

- AP OFF
- PITCH PULL UP
Pull up to full back stick and maintain.
- THRUST LEVERS TOGA
- SPEED BRAKES LEVER CHECK RETRACTED
- BANK WINGS LEVEL TO INITIATE PULL UP
THEN ADJUST AS RQRD

● **When flight path is safe and GPWS warning stops :**

Decrease pitch attitude and accelerate.

● **When speed is above VLS, and vertical speed is positive :**

Clean up aircraft as required.

■ **"TERRAIN TERRAIN" – "TOO LOW TERRAIN"** :

Adjust the flight path or initiate a go-around.

■ **"TERRAIN AHEAD"** :

Adjust the flight path. Stop descent. Climb and/or turn, as necessary, based on analysis of all available instruments and information.

■ **"SINK RATE" "DON'T SINK"** :

Adjust pitch attitude and thrust to silence the alert.

■ **"TOO LOW GEAR" – "TOO LOW FLAPS"** :

Perform a go-around.

■ **"GLIDE SLOPE"** :

Establish the aircraft on the glideslope, or switch OFF the G/S mode pushbutton, if flight below the glideslope is intentional (non precision approach (NPA)).

R

LOSS OF BRAKING

● IF AUTOBRAKE IS SELECTED :

– BRAKE PEDALS PRESS

● IF NO BRAKING AVAILABLE :

– REV MAX

– BRAKE PEDALS RELEASE

– A/SKID & N/W STRG OFF

– BRAKE PEDALS PRESS

– MAX BRK PR 1000 PSI

● If STILL NO BRAKING :

– PARKING BRAKE SHORT AND SUCCESSIVE
APPLICATIONS

GPWS ALERTS

CAUTION

During night or IMC conditions, apply the procedure immediately. Do not delay reaction for diagnosis.

During daylight VMC conditions, with terrain and obstacles clearly in sight, the alert may be considered cautionary. Take positive corrective action until the alert stops, or a safe trajectory is ensured.

■ "AVOID TERRAIN"

Simultaneously :

- AP OFF
- PITCH PULL UP
- THRUST LEVERS TOGA
- SPEEDBRAKES lever CHECK RETRACTED
- BANK ... WINGS LEVEL TO INITIATE PULL UP then ADJUST

● When flight path is safe, and GPWS warning stops :

- Decrease pitch attitude and accelerate.

● When speed is above VLS, and vertical speed is positive :

- Clean up aircraft, as required.

■ "PULL UP" – "TERRAIN TERRAIN PULL UP" – "TERRAIN AHEAD PULL UP"

Simultaneously :

- AP OFF
- PITCH PULL UP
- THRUST LEVERS TOGA
- SPEEDBRAKE lever CHECK RETRACTED
- BANK WINGS LEVEL TO INITIATE PULL UP
then ADJUST AS RQRD

● When the flight path is safe, and GPWS warning stops :

- Decrease pitch attitude and accelerate.

● When speed is above VLS, and vertical speed is positive :

- Clean up aircraft, as required.



LOSS OF BRAKING

- IF AUTOBRAKE IS SELECTED :
 - BRAKE PEDALS PRESS
- IF NO BRAKING AVAILABLE :
 - REV MAX
 - BRAKE PEDALS RELEASE
 - A/SKID & N/W STRG OFF
 - BRAKE PEDALS PRESS
 - MAX BRK PR 1000 PSI
- If STILL NO BRAKING :
 - PARKING BRAKE SHORT AND SUCCESSIVE APPLICATIONS

EGPWS ALERTS

CAUTION

During night or IMC conditions, apply the procedure immediately. Do not delay reaction for diagnosis.

During daylight VMC conditions, with terrain and obstacles clearly in sight, the alert may be considered cautionary. Take positive corrective action until the alert stops or a safe trajectory is ensured.

■ **"PULL UP" – "TERRAIN TERRAIN PULL UP" – "TERRAIN AHEAD PULL UP" – "OBSTACLE AHEAD PULL UP" :**

Simultaneously :

- AP OFF
- PITCH PULL UP
Pull up to full backstick and maintain.
- THRUST LEVERS TOGA
- SPEED BRAKES LEVER CHECK RETRACTED
- BANK WINGS LEVEL TO INITIATE PULL UP
THEN ADJUST AS RQRD

● **When flight path is safe and GPWS warning stops :**

Decrease pitch attitude and accelerate.

● **When speed is above VLS, and vertical speed is positive :**

Clean up aircraft, as required.

■ **"TERRAIN TERRAIN" – "TOO LOW TERRAIN" :**

Adjust the flight path or initiate a go-around.

■ **"TERRAIN AHEAD" – "OBSTACLE AHEAD" :**

Adjust the flight path. Stop descent. Climb and/or turn, as necessary, based on analysis of all available instruments and information.

■ **"SINK RATE" – "DON'T SINK" :**

Adjust pitch attitude and thrust to silence the alert.

■ **"TOO LOW GEAR" – "TOO LOW FLAPS" :**

Perform a go-around.

■ **"GLIDE SLOPE" :**

Establish the aircraft on the glideslope, or switch OFF the G/S mode pushbutton, if flight below the glideslope is intentional (non precision approach (NPA)).

R

GPWS ALERTS (Cont'd)

- **"TERRAIN TERRAIN" "TOO LOW TERRAIN" :**
Adjust the flight path, or initiate a go-around.
- **"TERRAIN AHEAD" :**
Adjust the flight path. Stop descent. Climb and/or turn, as necessary, based on an analysis of all available instruments and information.
- **"SINK RATE" "DON'T SINK" :**
Adjust pitch attitude and thrust to silence the alert.
- **"TOO LOW GEAR" – "TOO LOW FLAPS" :**
Perform a go-around.
- **"GLIDE SLOPE" :**
Establish the aircraft on the glide slope, or switch OFF the G/S mode pushbutton, if flight below the glide slope is intentional (non precision approach (NPA)).

R

TCAS WARNINGS

■ **Traffic advisory : "TRAFFIC" messages**

- Do not maneuver based on a TA alone.
- Attempt to see the reported traffic.

■ **Resolution advisory : All "CLIMB" and "DESCEND" or "MAINTAIN VERTICAL SPEED MAINTAIN" or "ADJUST VERTICAL SPEED ADJUST" or "MONITOR VERTICAL SPEED" type messages**

- AP (if engaged) OFF
- BOTH FDs OFF
- Respond promptly and smoothly to an RA by adjusting or maintaining the vertical speed, as required, to reach the green area and/or avoid the red area of the vertical speed scale.

NOTE : Avoid excessive maneuvers while aiming to keep the vertical speed just outside the red area of the VSI, and within the green area. If necessary, use the full speed range between $V_{0,max}$ and V_{max} .

- Respect stall, GPWS, or windshear warning.
- Notify ATC.
- When "CLEAR OF CONFLICT" is announced :
 - . Resume normal navigation in accordance with ATC clearance.
 - . AP/FD can be re-engaged as desired.

● **GO AROUND procedure must be performed when an RA "CLIMB" or "INCREASE CLIMB" is triggered on final approach.**

NOTE : Resolution Advisories (RA) are inhibited below 900 feet.

R
R
R
R
R
R
R
R

ENG DUAL FAILURE – FUEL REMAINING

R The flight crew should apply this paper procedure and then, if time permits, clear ECAM warnings and check the ECAM STATUS page.

LAND ASAP

- ENG MODE SEL IGN
- THRUST LEVERS IDLE
- OPTIMUM RELIGHT SPD 280 KT

R In the case of a speed indication failure (volcanic ash), Pitch attitude for optimum relight speed is :

WEIGHT	Pitch (°)
At or below 50 000 kg/110 000 lb	– 2.5
60 000 kg/132 000 lb	– 1.5
70 000 kg/154 000 lb	– 0.5

R At 280 knots, the aircraft can fly up to about 2.2 NM per 1000 feet (with no wind).

- LANDING STRATEGY DETERMINE
Determine whether a runway can be reached, or the most appropriate place for a forced landing/ditching.
- EMER ELEC PWR MAN ON
- VHF1/HF1 (◀)/ATC1 USE
- ATC NOTIFY
- FAC 1 OFF THEN ON
Resetting FAC 1 also enables rudder trim recovery, even if no indication is available.

● **IF NO RELIGHT AFTER 30 SEC :**

- ENG MASTERS OFF 30 S/ON
Unassisted start attempts can be repeated until successful, or until APU bleed is available.
- CREW OXY MASKS (Above FL 100) ON

R ● **WHEN APU AVAIL FL < 200 :**

- WING ANTI ICE OFF
- APU BLEED ON
- ENG MASTERS (one at a time) OFF 30 S/ON



TCAS WARNINGS

■ **Traffic advisory : "TRAFFIC" messages**

- Do not maneuver based on a TA alone.
- Attempt to see the reported traffic.

 ■ **Resolution advisory : All "CLIMB" and "DESCEND" or "MAINTAIN VERTICAL SPEED MAINTAIN" or "ADJUST VERTICAL SPEED ADJUST" or "MONITOR VERTICAL SPEED" type messages**

- AP (if engaged) OFF
- BOTH FDs OFF
- Respond promptly and smoothly to an RA by adjusting or maintaining the vertical speed, as required, to reach the green area and/or avoid the red area of the vertical speed scale.

NOTE : Avoid excessive maneuvers while aiming to keep the vertical speed just outside the red area of the VSI, and within the green area. If necessary, use the full speed range between $V_{0,max}$ and V_{max} .

- Respect stall, GPWS, or windshear warning.
- Notify ATC.
- When "CLEAR OF CONFLICT" is announced :
 - . Resume normal navigation in accordance with ATC clearance.
 - . AP/FD can be re-engaged as desired.

 ● **GO AROUND procedure must be performed when an RA "CLIMB" or "INCREASE CLIMB" is triggered on final approach.**

NOTE : Resolution Advisories (RA) are inhibited below 900 feet.

R
R
R
R
R
R
R
R

ENG DUAL FAILURE - FUEL REMAINING

R The flight crew should apply this paper procedure and then, if time permits, clear ECAM warnings and check the ECAM STATUS page.

LAND ASAP

- ENG MODE SEL IGN
- THRUST LEVERS IDLE
- OPTIMUM RELIGHT SPD 280 KT

R In the case of a speed indication failure (volcanic ash), Pitch attitude for optimum relight speed is :

WEIGHT	Pitch (°)
At or below 50 000 kg/110 000 lb	- 2.5
60 000 kg/132 000 lb	- 1.5
70 000 kg/154 000 lb	- 0.5

R At 280 kt, the aircraft can fly up to about 2.2 NM per 1000 feet (with no wind).

- LANDING STRATEGY DETERMINE
Determine whether a runway can be reached, or the most appropriate place for a forced landing/ditching.
- EMER ELEC PWR MAN ON
- VHF1/HF1 (◀)/ATC1 USE
- ATC NOTIFY
- FAC 1 OFF THEN ON
Resetting FAC 1 also enables rudder trim recovery, even if no indication is available.

● **IF NO RELIGHT AFTER 30 SEC :**

- ENG MASTERS OFF 30 S/ON
Unassisted start attempts can be repeated until successful, or until APU bleed is available.

● **IF UNSUCCESSFUL :**

- CREW OXY MASKS (Above FL 100) ON

● **WHEN BELOW FL 250**

- APU (IF AVAIL) START

● **WHEN BELOW FL 200**

- WING ANTI ICE OFF
- APU BLEED ON
- ENG MASTERS (one at a time) OFF 30 S/ON



R
R
R
R
R
R
R
R
R

TCAS WARNINGS

■ **Traffic advisory : "TRAFFIC" messages**

- Do not maneuver based on a TA alone.
- Attempt to see the reported traffic.

■ **Resolution advisory : All "CLIMB" and "DESCEND" or "MAINTAIN VERTICAL SPEED MAINTAIN" or "ADJUST VERTICAL SPEED ADJUST" or "MONITOR VERTICAL SPEED" type messages**

- AP (if engaged) OFF
- BOTH FDs OFF
- Respond promptly and smoothly to an RA by adjusting or maintaining the vertical speed, as required, to reach the green area and/or avoid the red area of the vertical speed scale.

NOTE : Avoid excessive maneuvers while aiming to keep the vertical speed just outside the red area of the VSI, and within the green area. If necessary, use the full speed range between $V_{0,max}$ and V_{max} .

- Respect stall, GPWS, or windshear warning.
- Notify ATC.
- When "CLEAR OF CONFLICT" is announced :
 - . Resume normal navigation in accordance with ATC clearance.
 - . AP/FD can be re-engaged as desired.

● **GO AROUND procedure must be performed when an RA "CLIMB" or "INCREASE CLIMB" is triggered on final approach.**

NOTE : Resolution Advisories (RA) are inhibited below 900 feet.

R
R
R
R
R
R
R
R

ENG DUAL FAILURE – FUEL REMAINING

R The flight crew should apply this paper procedure and then, if time permits, clear ECAM warnings and check the ECAM STATUS page.

LAND ASAP

- ENG MODE SEL IGN
- THRUST LEVERS IDLE
- OPTIMUM RELIGHT SPD 280 KT

R In the case of a speed indication failure (volcanic ash), Pitch attitude for optimum relight speed is :

WEIGHT	Pitch (°)
At or below 60 000 kg/132 000 lb	– 2.5
70 000 kg/154 000 lb	– 1.5
80 000 kg/176 000 lb	– 0.5

R At 280 knots, the aircraft can fly up to about 2.4 NM per 1000 feet (with no wind).

- LANDING STRATEGY DETERMINE
Determine whether a runway can be reached, or the most appropriate place for a forced landing/ditching.
- EMER ELEC PWR MAN ON
- VHF1/HF1 (◀)/ATC1 USE
- ATC NOTIFY
- FAC 1 OFF THEN ON
Resetting FAC 1 also enables rudder trim recovery, even if no indication is available.

● **IF NO RELIGHT AFTER 30 SEC :**

- ENG MASTERS OFF 30 S/ON
Unassisted start attempts can be repeated until successful, or until APU bleed is available.

● **IF UNSUCCESSFUL :**

- CREW OXY MASKS (Above FL 100) ON

● **WHEN BELOW FL 250**

- APU (IF AVAIL) START

● **WHEN BELOW FL 200**

- WING ANTI ICE OFF
- APU BLEED ON
- ENG MASTERS (one at a time) OFF 30 S/ON



R
R
R
R
R
R
R
R
R

TCAS WARNINGS

■ **Traffic advisory : "TRAFFIC" messages**

- Do not maneuver based on a TA alone.
- Attempt to see the reported traffic.

 ■ **Resolution advisory : All "CLIMB" and "DESCEND" or "MAINTAIN VERTICAL SPEED MAINTAIN" or "ADJUST VERTICAL SPEED ADJUST" or "MONITOR VERTICAL SPEED" type messages**

- AP (if engaged) OFF
- BOTH FDs OFF
- Respond promptly and smoothly to an RA by adjusting or maintaining the vertical speed, as required, to reach the green area and/or avoid the red area of the vertical speed scale.

NOTE : Avoid excessive maneuvers while aiming to keep the vertical speed just outside the red area of the VSI, and within the green area. If necessary, use the full speed range between $V_{0,max}$ and V_{max} .

- Respect stall, GPWS, or windshear warning.
- Notify ATC.
- When "CLEAR OF CONFLICT" is announced :
 - . Resume normal navigation in accordance with ATC clearance.
 - . AP/FD can be re-engaged as desired.

 ● **GO AROUND procedure must be performed when an RA "CLIMB" or "INCREASE CLIMB" is triggered on final approach.**

NOTE : Resolution Advisories (RA) are inhibited below 900 feet.

R
R
R
R
R
R
R
R

ENG DUAL FAILURE – FUEL REMAINING

R The flight crew should apply this paper procedure and then, if time permits, clear ECAM warnings and check the ECAM STATUS page.

LAND ASAP

- ENG MODE SEL IGN
- THRUST LEVERS IDLE
- OPTIMUM RELIGHT SPD 280 KT

R In the case of a speed indication failure (volcanic ash), Pitch attitude for optimum relight speed is :

WEIGHT	Pitch (°)
At or below 50 000 kg/110 000 lb	– 2.5
60 000 kg/132 000 lb	– 1.5
70 000 kg/154 000 lb	– 0.5

R At 280 knots, the aircraft can fly up to about 2.2 NM per 1000 feet (with no wind).

- LANDING STRATEGY DETERMINE
Determine whether a runway can be reached, or the most appropriate place for a forced landing/ditching.
- EMER ELEC PWR MAN ON
- VHF1/HF1 (◀)/ATC1 USE
- ATC NOTIFY
- FAC1 OFF THEN ON
Resetting FAC 1 also enables rudder trim recovery, even if no indication is available.

R ● **IF NO RELIGHT AFTER 30 SEC :**

- ENG MASTERS OFF 30 S/ON
Unassisted start attempts can be repeated until successful, or until APU bleed is available.

R ● **IF UNSUCCESSFUL :**

- CREW OXY MASKS (Above FL 100) ON

R ● **WHEN BELOW FL 250**

- APU (IF AVAIL) START

R ● **WHEN BELOW FL 200**

- WING ANTI ICE OFF
- APU BLEED ON
- ENG MASTERS (one at a time) OFF 30 S/ON



ENG DUAL FAILURE - FUEL REMAINING (CONT'D)

- When APU bleed is available or if engine restart is definitively considered impossible :

– OPTIMUM SPEED REFER TO TABLE BELOW

GREEN DOT SPEED WITH ALL ENGINES INOPERATIVE (KNOTS)			
Weight (1000 kg)	At or below FL 200	FL 300	FL 400
78	236	246	256
76	232	242	252
72	224	234	244
68	216	226	236
64	208	218	228
60	200	210	220
56	192	202	212
52	184	194	204
48	176	186	196
44	168	178	188
40	160	170	180

At green dot speed, the aircraft can fly up to approximately 2.5 NM per 1000 feet (with no wind).

Average rate of descent is approximately 1600 feet/min.

- CABIN AND COCKPIT PREPARE
- CABIN SIGNS ON
- GALLEY OFF
- USE RUDDER WITH CARE

● WHEN BELOW FL 150

- RAM AIR ON

APPROACH PREPARATION

NOTE : Final descent slope, when configured (CONF 3 ; L/G DOWN) will be approximately 800 feet/NM (with no wind).

- BARO SET
- CREW MASKS/OXY SUPPLY (below FL 100) OFF



ENG DUAL FAILURE – FUEL REMAINING (Cont'd)

■ IF FORCED LANDING ANTICIPATED

APPROACH

- FOR LDG USE FLAP 3
Only slats extend, and slowly.
- MIN APPR SPEED 150 KT
- VAPP DETERMINE
Vapp is the maximum between Vref + 25 knots / 150 knots :

Weight (1000 kg)	40	44	48	52	56	60	64	68	72	76	78
Vapp	150	150	150	150	150	154	159	163	167	171	172

- **At a suitable altitude (not below 3000 feet AGL), configure the aircraft for landing (CONF 3 ; L/G DOWN) :**

- **When in CONF 3 and VAPP :**

- GRAVITY GEAR EXTN handcrank PULL AND TURN
Disregard "USE MAN PITCH TRIM" on the PFD : The stabilizer is frozen due to insufficient hydraulic power.

- **When L/G downlocked**

- L/G lever DOWN
- APPROACH SPEED ADJUST
Adjust the speed to the determined Vapp. Nevertheless, to reach the landing field/runway, the approach speed may be adjusted up to 200 knots (max speed with slats extended).
- GND SPLR ARM
- MAX BRK PR 1000 PSI

AT 2000 FEET AGL

- CABIN NOTIFY FOR LANDING

AT 500 FEET AGL

- BRACE FOR IMPACT ORDER

AT TOUCHDOWN

- ENG MASTERS OFF
- APU MASTER SW OFF
- BRAKES ON ACCU ONLY

AFTER LANDING

- **When the aircraft has stopped :**

- PARKING BRK ON
- ATC NOTIFY
- FIRE pushbutton (ENG and APU) PUSH
- AGENTS (ENG and APU) DISCH
Engine Agent 2 is not available.
- EVACUATION INITIATE
- ELT ◀ CHECK EMITTING
If not, switch on the transmitter



ENG DUAL FAILURE - FUEL REMAINING (CONT'D)

- When APU bleed is available or if engine restart is definitively considered impossible :

– OPTIMUM SPEED REFER TO TABLE BELOW

GREEN DOT SPEED WITH ALL ENGINES INOPERATIVE (KNOTS)			
Weight (1000 kg)	At or below FL 200	FL 300	FL 400
78	241	251	261
76	237	247	257
72	229	239	249
68	221	231	241
64	213	223	233
60	205	215	225
56	197	207	217
52	189	199	209
48	181	191	201
44	173	183	193
40	165	175	185

At green dot speed, the aircraft can fly up to approximately 2.5 NM per 1000 feet (with no wind).

Average rate of descent is approximately 1600 feet/min.

- CABIN AND COCKPIT PREPARE
- CABIN SIGNS ON
- COMMERCIAL OFF
- USE RUDDER WITH CARE

● WHEN BELOW FL 150

- RAM AIR ON

APPROACH PREPARATION

NOTE : Final descent slope, when configured (CONF 3 ; L/G DOWN) will be approximately 800 feet/NM (with no wind).

- BARO SET
- CREW MASKS/OXY SUPPLY (below FL 100) OFF



ENG DUAL FAILURE – FUEL REMAINING (Cont'd)

■ IF FORCED LANDING ANTICIPATED

APPROACH

- FOR LDG USE FLAP 3
Only slats extend, and slowly.
- MIN APPR SPEED 150 KT
- VAPP DETERMINE
Vapp is the maximum between Vref + 25 knots / 150 knots :

Weight (1000 kg)	40	44	48	52	56	60	64	68	72	76
Vapp	150	150	150	150	150	150	154	158	162	166

● At a suitable altitude (not below 3000 feet AGL), configure the aircraft for landing (CONF 3 ; L/G DOWN) :

● When in CONF 3 and VAPP :

- GRAVITY GEAR EXTN handcrank PULL AND TURN
Disregard "USE MAN PITCH TRIM" on the PFD : The stabilizer is frozen due to insufficient hydraulic power.

● When L/G downlocked

- L/G lever DOWN
- APPROACH SPEED ADJUST
Adjust the speed to the determined Vapp. Nevertheless, to reach the landing field/runway, the approach speed may be adjusted up to 200 knots (max speed with slats extended).
- GND SPLR ARM
- MAX BRK PR 1000 PSI

AT 2000 FEET AGL

- CABIN NOTIFY FOR LANDING

AT 500 FEET AGL

- BRACE FOR IMPACT ORDER

AT TOUCHDOWN

- ENG MASTERS OFF
- APU MASTER SW OFF
- BRAKES ON ACCU ONLY

AFTER LANDING

● When the aircraft has stopped :

- PARKING BRK ON
- ATC NOTIFY
- FIRE pushbutton (ENG and APU) PUSH
- AGENTS (ENG and APU) DISCH
Engine Agent 2 is not available.
- EVACUATION INITIATE
- ELT ◀ CHECK EMITTING
If not, switch on the transmitter



ENG DUAL FAILURE - FUEL REMAINING (CONT'D)

- When APU bleed is available or if engine restart is definitively considered impossible :

– OPTIMUM SPEED REFER TO TABLE BELOW

GREEN DOT SPEED WITH ALL ENGINES INOPERATIVE (KNOTS)			
Weight (1000 kg)	At or below FL 200	FL 300	FL 400
78	236	246	256
76	232	242	252
72	224	234	244
68	216	226	236
64	208	218	228
60	200	210	220
56	192	202	212
52	184	194	204
48	176	186	196
44	168	178	188
40	160	170	180

At green dot speed, the aircraft can fly up to approximately 2.5 NM per 1000 feet (with no wind).

Average rate of descent is approximately 1600 feet/min.

- CABIN AND COCKPIT PREPARE
- CABIN SIGNS ON
- COMMERCIAL OFF
- USE RUDDER WITH CARE

● WHEN BELOW FL 150

- RAM AIR ON

APPROACH PREPARATION

NOTE : Final descent slope, when configured (CONF 3 ; L/G DOWN) will be approximately 800 feet/NM (with no wind).

- BARO SET
- CREW MASKS/OXY SUPPLY (below FL 100) OFF



ENG DUAL FAILURE – FUEL REMAINING (Cont'd)

■ IF FORCED LANDING ANTICIPATED

APPROACH

- FOR LDG USE FLAP 3
Only slats extend, and slowly.
- MIN APPR SPEED 150 KT
- VAPP DETERMINE
Vapp is the maximum between Vref + 25 knots / 150 knots :

Weight (1000 kg)	40	44	48	52	56	60	64	68	72	76	78
Vapp	150	150	150	150	150	154	159	163	167	171	172

- **At a suitable altitude (not below 3000 feet AGL), configure the aircraft for landing (CONF 3 ; L/G DOWN) :**

- **When in CONF 3 and VAPP :**

- GRAVITY GEAR EXTN handcrank PULL AND TURN
Disregard "USE MAN PITCH TRIM" on the PFD : The stabilizer is frozen due to insufficient hydraulic power.

- **When L/G downlocked**

- L/G lever DOWN
- APPROACH SPEED ADJUST
Adjust the speed to the determined Vapp. Nevertheless, to reach the landing field/runway, the approach speed may be adjusted up to 200 knots (max speed with slats extended).
- GND SPLR ARM
- MAX BRK PR 1000 PSI

AT 2000 FEET AGL

- CABIN NOTIFY FOR LANDING

AT 500 FEET AGL

- BRACE FOR IMPACT ORDER

AT TOUCHDOWN

- ENG MASTERS OFF
- APU MASTER SW OFF
- BRAKES ON ACCU ONLY

AFTER LANDING

- **When the aircraft has stopped :**

- PARKING BRK ON
- ATC NOTIFY
- FIRE pushbutton (ENG and APU) PUSH
- AGENTS (ENG and APU) DISCH
Engine Agent 2 is not available.
- EVACUATION INITIATE
- ELT  CHECK EMITTING
If not, switch on the transmitter



ENG DUAL FAILURE - FUEL REMAINING (CONT'D)

- When APU bleed is available or if engine restart is definitively considered impossible :

– OPTIMUM SPEED REFER TO TABLE BELOW

GREEN DOT SPEED WITH ALL ENGINES INOPERATIVE (KNOTS)			
Weight (1000 kg)	At or below FL 200	FL 300	FL 400
78	236	246	256
76	232	242	252
72	224	234	244
68	216	226	236
64	208	218	228
60	200	210	220
56	192	202	212
52	184	194	204
48	176	186	196
44	168	178	188
40	160	170	180

At green dot speed, the aircraft can fly up to approximately 2.5 NM per 1000 feet (with no wind).

Average rate of descent is approximately 1600 feet/min.

- CABIN AND COCKPIT PREPARE
- CABIN SIGNS ON
- GALY & CAB OFF
- USE RUDDER WITH CARE

● WHEN BELOW FL 150

- RAM AIR ON

APPROACH PREPARATION

NOTE : Final descent slope, when configured (CONF 3 and L/G DOWN) will be approximately 800 feet/NM (with no wind).

- BARO SET
- CREW MASKS/OXY SUPPLY (below FL 100) OFF



ENG DUAL FAILURE – FUEL REMAINING (Cont'd)

■ IF FORCED LANDING ANTICIPATED

APPROACH

- FOR LDG USE FLAP 3
Only slats extend, and slowly.
- MIN APPR SPEED 150 KT
- VAPP DETERMINE
Vapp is the maximum between Vref + 25 knots / 150 knots :

Weight (1000 kg)	40	44	48	52	56	60	64	68	72	76	78
Vapp	150	150	150	150	150	154	159	163	167	171	172

- **At a suitable altitude (not below 3000 feet AGL), configure the aircraft for landing (CONF 3 ; L/G DOWN) :**

- **When in CONF 3 and VAPP :**

- GRAVITY GEAR EXTN handcrank PULL AND TURN
Disregard "USE MAN PITCH TRIM" on the PFD : The stabilizer is frozen due to insufficient hydraulic power.

- **When L/G downlocked**

- L/G lever DOWN
- APPROACH SPEED ADJUST
Adjust the speed to the determined Vapp. Nevertheless, to reach the landing field/runway, the approach speed may be adjusted up to 200 knots (max speed with slats extended).
- GND SPLR ARM
- MAX BRK PR 1000 PSI

AT 2000 FEET AGL

- CABIN NOTIFY FOR LANDING

AT 500 FEET AGL

- BRACE FOR IMPACT ORDER

AT TOUCHDOWN

- ENG MASTERS OFF
- APU MASTER SW OFF
- BRAKES ON ACCU ONLY

AFTER LANDING

- **When the aircraft has stopped :**

- PARKING BRK ON
- ATC NOTIFY
- FIRE pushbutton (ENG and APU) PUSH
- AGENTS (ENG and APU) DISCH
Engine Agent 2 is not available.
- EVACUATION INITIATE
- ELT  CHECK EMITTING
If not, switch on the transmitter



ENG DUAL FAILURE - FUEL REMAINING (CONT'D)

- When APU bleed is available or if engine restart is definitively considered impossible :

– OPTIMUM SPEED REFER TO TABLE BELOW

GREEN DOT SPEED WITH ALL ENGINES INOPERATIVE (KNOTS)			
Weight (1000 kg)	At or below FL 200	FL 300	FL 400
94	251	261	271
92	248	258	268
88	242	252	262
86	239	249	259
84	236	246	256
82	233	243	253
80	230	240	250
78	227	237	247
76	224	234	244
74	221	231	241
72	218	228	238
70	215	225	235
68	212	222	232
66	209	219	229
64	206	216	226
62	203	213	223
60	200	210	220
58	197	207	217
56	194	204	214
54	191	201	211
52	188	198	208

At green dot speed, the aircraft can fly up to approximately 2.5 NM per 1000 feet (with no wind).

Average rate of descent is approximately 1700 feet/min.

- CABIN AND COCKPIT PREPARE
- CABIN SIGNS ON
- COMMERCIAL OFF
- USE RUDDER WITH CARE

● WHEN BELOW FL 150

- RAM AIR ON

APPROACH PREPARATION

NOTE : Final descent slope, when configured (CONF 3 and L/G DOWN) will be approximately 900 feet/NM (with no wind).

- BARO SET
- CREW MASKS/OXY SUPPLY (below FL 100) OFF



ENG DUAL FAILURE – FUEL REMAINING (Cont'd)

■ IF FORCED LANDING ANTICIPATED

APPROACH

- FOR LDG USE FLAP 3
Only slats extend, and slowly.
- MIN APPR SPEED 160 KT
- VAPP DETERMINE
Vapp is the maximum between Vref + 30 knots / 160 knots :

Weight (1000 kg)	52	56	60	64	68	72	76	80	84	88	92	94
Vapp	160	160	160	160	163	167	171	174	178	181	185	187

● At a suitable altitude (not below 3000 feet AGL), configure the aircraft for landing (CONF 3 ; L/G DOWN) :

● When in CONF 3 and VAPP :

- GRAVITY GEAR EXTN handcrank PULL AND TURN
Disregard "USE MAN PITCH TRIM" on the PFD : The stabilizer is frozen due to insufficient hydraulic power.

● When L/G downlocked

- L/G lever DOWN
- APPROACH SPEED ADJUST
Adjust the speed to the determined Vapp. Nevertheless, to reach the landing field/runway, the approach speed may be adjusted up to 215 knots (max speed with slats extended).
- GND SPLR ARM
- MAX BRK PR 1000 PSI

AT 2000 FEET AGL

- CABIN NOTIFY FOR LANDING

AT 500 FEET AGL

- BRACE FOR IMPACT ORDER

AT TOUCHDOWN

- ENG MASTERS OFF
- APU MASTER SW OFF
- BRAKES ON ACCU ONLY

AFTER LANDING

● When the aircraft has stopped :

- PARKING BRK ON
- ATC NOTIFY
- FIRE pushbutton (ENG and APU) PUSH
- AGENTS (ENG and APU) DISCH
Engine Agent 2 is not available.
- EVACUATION INITIATE
- ELT ◀ CHECK EMITTING
If not, switch on the transmitter



ENG DUAL FAILURE – FUEL REMAINING (Cont'd)

■ IF DITCHING ANTICIPATED

APPROACH

- FOR LDG USE FLAP 3
Only slats extend, and slowly.
- MIN APPR SPEED 150 KT
- VAPP DETERMINE
VAPP is the maximum between Vref + 25 knots / 150 knots :

Weight (1000 kg)	40	44	48	52	56	60	64	68	72	76
Vapp	150	150	150	150	150	150	154	158	162	166

● At a suitable altitude (not below 3000 feet AGL), configure the aircraft for ditching (CONF 3 ; L/G UP)

- L/G lever CHECK UP

AT 2000 FEET AGL

- CABIN NOTIFY FOR DITCHING
- DITCHING pushbutton ON
*In case of strong crosswind, ditch face to the wind.
In the absence of strong crosswind, prefer ditching parallel to the swell. Touchdown with approximately 11 degrees of pitch and minimum aircraft vertical speed.*

AT 500 FEET AGL

- BRACE FOR IMPACT ORDER

AT TOUCHDOWN

- ENG MASTERS OFF
- APU MASTER SW OFF

AFTER DITCHING

- ATC (VHF 1) NOTIFY
- FIRE pushbutton (ENG and APU) PUSH
- AGENT (ENG and APU) DISCH
Engine Agent 2 is not available.
- EVACUATION INITIATE
- ELT ◀ CHECK EMITTING
If not, switch on the transmitter

R

R

ENG DUAL FAILURE – NO FUEL REMAINING

The flight crew should apply this paper procedure and then, if time permits, clear ECAM warnings and check the ECAM STATUS page.

- THRUST LEVERS IDLE
- FAC 1 OFF THEN ON
Resetting FAC 1 also enables rudder trim recovery, even if no indication is available.
- OPTIMUM SPEED 215 KT/GREEN DOT
Initially, fly 215 knots, because the PFD may not display the correct green dot speed. Then fly the green dot speed according to the following table :

GREEN DOT SPEED WITH ALL ENGINES INOPERATIVE (KNOTS)			
Weight (1000 kg)	At or below FL 200	FL 300	FL 400
68	221	231	241
64	213	223	233
60	205	215	225
56	197	207	217
52	189	199	209
48	181	191	201
44	173	183	193
40	165	175	185

At green dot speed, the aircraft can fly up to approximately 2.5 NM per 1000 feet (with no wind). Average rate of descent is approximately 1600 feet/min.

- LANDING STRATEGY DETERMINE
Determine whether a runway can be reached or the most appropriate place for a forced landing/ditching.
- EMER ELEC POWER (if EMER GEN not in line) MAN ON
- VHF1/HF1 (if installed)/ATC1 USE
- ATC NOTIFY
- CREW OXY MASKS (Above FL 100) ON
- CABIN AND COCKPIT PREPARE
- SIGNS ON
- COMMERCIAL OFF
- USE RUDDER WITH CARE
- **WHEN BELOW FL 150**
- RAM AIR ON

APPROACH PREPARATION

NOTE : Final descent slope, when configured (CONF 3/L/G DOWN), will be approximately 800 feet/NM (with no wind).

- BARO SET
- CREW MASKS/OXY SUPPLY (below FL 100) OFF



ENG DUAL FAILURE – FUEL REMAINING (Cont'd)

■ IF DITCHING ANTICIPATED

APPROACH

- R
- FOR LDG USE FLAP 3
Only slats extend, and slowly.
 - MIN APPR SPEED 160 KT
 - VAPP DETERMINE
VAPP is the maximum between Vref + 30 knots / 160 knots :

Weight (1000 kg)	52	56	60	64	68	72	76	80	84	88	92	94
Vapp	160	160	160	160	163	167	171	174	178	181	185	187

- **At a suitable altitude (not below 3000 feet AGL), configure the aircraft for ditching (CONF 3 ; L/G UP)**

- L/G lever CHECK UP

AT 2000 FEET AGL

- CABIN NOTIFY FOR DITCHING
- DITCHING pushbutton ON
*In case of strong crosswind, ditch face to the wind.
In the absence of strong crosswind, prefer ditching parallel to the swell. Touchdown with approximately 11 degrees of pitch and minimum aircraft vertical speed.*

AT 500 FEET AGL

- BRACE FOR IMPACT ORDER

AT TOUCHDOWN

- ENG MASTERS OFF
- APU MASTER SW OFF

AFTER DITCHING

- R
- ATC (VFH 1) NOTIFY
 - FIRE pushbutton (ENG and APU) PUSH
 - AGENT (ENG and APU) DISCH
Engine Agent 2 is not available.
 - EVACUATION INITIATE
 - ELT ◀ CHECK EMITTING
If not, switch on the transmitter

ENG DUAL FAILURE – NO FUEL REMAINING

The flight crew should apply this paper procedure and then, if time permits, clear ECAM warnings and check the ECAM STATUS page.

- THRUST LEVERS IDLE
- FAC 1 OFF THEN ON
Resetting FAC 1 also enables rudder trim recovery, even if no indication is available.
- OPTIMUM SPEED 240 KT/GREEN DOT
Initially, fly 240 knots, because the PFD may not display the correct green dot speed. Then fly the green dot speed according to the following table :

GREEN DOT SPEED WITH ALL ENGINES INOPERATIVE (KNOTS)			
Weight (1000 kg)	At or below FL 200	FL 300	FL 400
80	230	240	250
78	227	237	247
76	224	234	244
74	221	231	241
72	218	228	238
70	215	225	235
68	212	222	232
66	209	219	229
64	206	216	226
62	203	213	223
60	200	210	220
58	197	207	217
56	194	204	214
54	191	201	211
52	188	198	208

At green dot speed, the aircraft can fly up to approximately 2.5 NM per 1000 feet (with no wind). Average rate of descent is approximately 1700 feet/min.

- LANDING STRATEGY DETERMINE
Determine whether a runway can be reached or the most appropriate place for a forced landing/ditching.
- EMER ELEC POWER (if EMER GEN not in line) MAN ON
- VHF1/HF1 (if installed)/ATC1 USE
- ATC NOTIFY
- CREW OXY MASKS (Above FL 100) ON
- CABIN AND COCKPIT PREPARE
- SIGNS ON
- COMMERCIAL OFF
- USE RUDDER WITH CARE

● **WHEN BELOW FL 150**

- RAM AIR ON

APPROACH PREPARATION

Note : Final descent slope, when configured (CONF 3/ L/G DOWN), will be approximately 900 feet/NM (with no wind).

- BARO SET
- CREW MASKS/OXY SUPPLY (below FL 100) OFF



ENG DUAL FAILURE – FUEL REMAINING (Cont'd)

■ IF DITCHING ANTICIPATED

APPROACH

- FOR LDG USE FLAP 3
Only slats extend, and slowly.
- MIN APPR SPEED 150 KT
- VAPP DETERMINE
VAPP is the maximum between Vref + 25 knots / 150 knots :

Weight (1000 kg)	40	44	48	52	56	60	64	68	72	76	78
Vapp	150	150	150	150	150	154	159	163	167	171	172

● At a suitable altitude (not below 3000 feet AGL), configure the aircraft for ditching (CONF 3 ; L/G UP)

- L/G lever CHECK UP

AT 2000 FEET AGL

- CABIN NOTIFY FOR DITCHING
- DITCHING pushbutton ON
*In case of strong crosswind, ditch face to the wind.
In the absence of strong crosswind, prefer ditching parallel to the swell. Touchdown with approximately 11 degrees of pitch and minimum aircraft vertical speed.*

AT 500 FEET AGL

- BRACE FOR IMPACT ORDER

AT TOUCHDOWN

- ENG MASTERS OFF
- APU MASTER SW OFF

AFTER DITCHING

- ATC (VHF 1) NOTIFY
- FIRE pushbutton (ENG and APU) PUSH
- AGENT (ENG and APU) DISCH
Engine Agent 2 is not available.
- EVACUATION INITIATE
- ELT ◀ CHECK EMITTING
If not, switch on the transmitter

R

R

ENG DUAL FAILURE – NO FUEL REMAINING

The flight crew should apply this paper procedure and then, if time permits, clear ECAM warnings and check the ECAM STATUS page.

- THRUST LEVERS IDLE
- FAC 1 OFF THEN ON
Resetting FAC 1 also enables rudder trim recovery, even if no indication is available.
- OPTIMUM SPEED 220 KT/GREEN DOT
Initially, fly 220 knots, because the PFD may not display the correct green dot speed. Then fly the green dot speed according to the following table :

GREEN DOT SPEED WITH ALL ENGINES INOPERATIVE (KNOTS)			
Weight (1000 kg)	At or below FL 200	FL 300	FL 400
68	216	226	236
64	208	218	228
60	200	210	220
56	192	202	212
52	184	194	204
48	176	186	196
44	168	178	188
40	160	170	180

At green dot speed, the aircraft can fly up to approximately 2.5 NM per 1000 feet (with no wind). Average rate of descent is approximately 1600 feet/min.

- LANDING STRATEGY DETERMINE
Determine whether a runway can be reached or the most appropriate place for a forced landing/ditching.
- EMER ELEC POWER (if EMER GEN not in line) MAN ON
- VHF1/HF1 (if installed)/ATC1 USE
- ATC NOTIFY
- CREW OXY MASKS (Above FL 100) ON
- CABIN AND COCKPIT PREPARE
- SIGNS ON
- GALLEY OFF
- USE RUDDER WITH CARE
- **WHEN BELOW FL 150**
 - RAM AIR ON

APPROACH PREPARATION

NOTE : Final descent slope, when configured (CONF 3/L/G DOWN), will be approximately 800 feet/NM (with no wind).

- BARO SET
- CREW MASKS/OXY SUPPLY (below FL 100) OFF



ENG DUAL FAILURE – FUEL REMAINING (Cont'd)

■ IF DITCHING ANTICIPATED

APPROACH

- FOR LDG USE FLAP 3
Only slats extend, and slowly.
- MIN APPR SPEED 150 KT
- VAPP DETERMINE
VAPP is the maximum between Vref + 25 knots / 150 knots :

Weight (1000 kg)	40	44	48	52	56	60	64	68	72	76	78
Vapp	150	150	150	150	150	154	159	163	167	171	172

● At a suitable altitude (not below 3000 feet AGL), configure the aircraft for ditching (CONF 3 ; L/G UP)

- L/G lever CHECK UP

AT 2000 FEET AGL

- CABIN NOTIFY FOR DITCHING
- DITCHING pushbutton ON
*In case of strong crosswind, ditch face to the wind.
In the absence of strong crosswind, prefer ditching parallel to the swell. Touchdown with approximately 11 degrees of pitch and minimum aircraft vertical speed.*

AT 500 FEET AGL

- BRACE FOR IMPACT ORDER

AT TOUCHDOWN

- ENG MASTERS OFF
- APU MASTER SW OFF

AFTER DITCHING

- ATC (VHF 1) NOTIFY
- FIRE pushbutton (ENG and APU) PUSH
- AGENT (ENG and APU) DISCH
Engine Agent 2 is not available.
- EVACUATION INITIATE
- ELT ◀ CHECK EMITTING
If not, switch on the transmitter

R

R

IAE Eng. : V2500/V2527/V2527E

Mod : 20268

A320-231/-232/-233

ENG DUAL FAILURE – NO FUEL REMAINING

The flight crew should apply this paper procedure and then, if time permits, clear ECAM warnings and check the ECAM STATUS page.

- THRUST LEVERS IDLE
- FAC 1 OFF THEN ON
Resetting FAC 1 also enables rudder trim recovery, even if no indication is available.
- OPTIMUM SPEED 220 KT/GREEN DOT
Initially, fly 220 knots, because the PFD may not display the correct green dot speed. Then fly the green dot speed according to the following table :

GREEN DOT SPEED WITH ALL ENGINES INOPERATIVE (KNOTS)			
Weight (1000 kg)	At or below FL 200	FL 300	FL 400
68	216	226	236
64	208	218	228
60	200	210	220
56	192	202	212
52	184	194	204
48	176	186	196
44	168	178	188
40	160	170	180

At green dot speed, the aircraft can fly up to approximately 2.5 NM per 1000 feet (with no wind). Average rate of descent is approximately 1600 feet/min.

- LANDING STRATEGY DETERMINE
Determine whether a runway can be reached or the most appropriate place for a forced landing/ditching.
- EMER ELEC POWER (if EMER GEN not in line) MAN ON
- VHF1/HF1 (if installed)/ATC1 USE
- ATC NOTIFY
- CREW OXY MASKS (Above FL 100) ON
- CABIN AND COCKPIT PREPARE
- SIGNS ON
- COMMERCIAL OFF
- USE RUDDER WITH CARE
- **WHEN BELOW FL 150**
- RAM AIR ON

APPROACH PREPARATION

NOTE : Final descent slope, when configured (CONF 3/L/G DOWN), will be approximately 800 feet/NM (with no wind).

- BARO SET
- CREW MASKS/OXY SUPPLY (below FL 100) OFF



ENG DUAL FAILURE – FUEL REMAINING (Cont'd)

■ IF DITCHING ANTICIPATED

APPROACH

- FOR LDG USE FLAP 3
Only slats extend, and slowly.
- MIN APPR SPEED 150 KT
- VAPP DETERMINE
VAPP is the maximum between Vref + 25 knots / 150 knots :

Weight (1000 kg)	40	44	48	52	56	60	64	68	72	76	78
Vapp	150	150	150	150	150	154	159	163	167	171	172

● At a suitable altitude (not below 3000 feet AGL), configure the aircraft for ditching (CONF 3 ; L/G UP)

- L/G lever CHECK UP

AT 2000 FEET AGL

- CABIN NOTIFY FOR DITCHING
- DITCHING pushbutton ON
*In case of strong crosswind, ditch face to the wind.
In the absence of strong crosswind, prefer ditching parallel to the swell. Touchdown with approximately 11 degrees of pitch and minimum aircraft vertical speed.*

AT 500 FEET AGL

- BRACE FOR IMPACT ORDER

AT TOUCHDOWN

- ENG MASTERS OFF
- APU MASTER SW OFF

AFTER DITCHING

- ATC (VHF 1) NOTIFY
- FIRE pushbutton (ENG and APU) PUSH
- AGENT (ENG and APU) DISCH
Engine Agent 2 is not available.
- EVACUATION INITIATE
- ELT ◀ CHECK EMITTING
If not, switch on the transmitter

R

R

ENG DUAL FAILURE – NO FUEL REMAINING

The flight crew should apply this paper procedure and then, if time permits, clear ECAM warnings and check the ECAM STATUS page.

- THRUST LEVERS IDLE
- FAC 1 OFF THEN ON
Resetting FAC 1 also enables rudder trim recovery, even if no indication is available.
- OPTIMUM SPEED 220 KT/GREEN DOT
Initially, fly 220 knots, because the PFD may not display the correct green dot speed. Then fly the green dot speed according to the following table :

GREEN DOT SPEED WITH ALL ENGINES INOPERATIVE (KNOTS)			
Weight (1000 kg)	At or below FL 200	FL 300	FL 400
68	216	226	236
64	208	218	228
60	200	210	220
56	192	202	212
52	184	194	204
48	176	186	196
44	168	178	188
40	160	170	180

At green dot speed, the aircraft can fly up to approximately 2.5 NM per 1000 feet (with no wind). Average rate of descent is approximately 1600 feet/min.

- LANDING STRATEGY DETERMINE
Determine whether a runway can be reached or the most appropriate place for a forced landing/ditching.
- EMER ELEC POWER (if EMER GEN not in line) MAN ON
- VHF1/HF1 (if installed)/ATC1 USE
- ATC NOTIFY
- CREW OXY MASKS (Above FL 100) ON
- CABIN AND COCKPIT PREPARE
- SIGNS ON
- GALY & CAB OFF
- USE RUDDER WITH CARE
- **WHEN BELOW FL 150**
- RAM AIR ON

APPROACH PREPARATION

NOTE : Final descent slope, when configured (CONF 3/L/G DOWN), will be approximately 800 feet/NM (with no wind).

- BARO SET
- CREW MASKS/OXY SUPPLY (below FL 100) OFF



ENG DUAL FAILURE - NO FUEL REMAINING (Cont'd)

IF FORCED LANDING ANTICIPATED

APPROACH

- FOR LDG USE FLAP 3
Only slats extend, and slowly.
- MIN APPR SPEED 160 KT
- VAPP DETERMINE
Vapp is the maximum between Vref+30 knots / 160 knots.

Weight (1000 kg)	52	56	60	64	68	72	76	80	84	88	92	94
Vapp	160	160	160	160	163	167	171	174	178	181	185	187

At a suitable altitude (not below 3000 feet AGL), configure the aircraft for landing (CONF 3 ; L/G DOWN)

When in CONF 3 and VAPP

- GRAVITY GEAR EXTN handcrank PULL AND TURN
Flight controls revert to direct law at landing gear extension. Wait for CONF 3 and VAPP before extending the landing gear to enable the aircraft to be trimmed for approach. Disregard "USE MAN PITCH TRIM" on the PFD, because the stabilizer is frozen in the position where it was at, when the windmilling was insufficient to provide hydraulic power.

When L/G downlocked

- L/G lever DOWN
- APPROACH SPEED ADJUST
Adjust the speed to the determined Vapp. Nevertheless, to reach the landing field/runway, the approach speed may be adjusted up to 215 knots (max speed with slats extended).
- GND SPLR ARM
- MAX BRK PR 1000 PSI

AT 2000 FEET AGL

- CABIN NOTIFY FOR LANDING

AT 500 FEET AGL

- BRACE FOR IMPACT ORDER

AT TOUCHDOWN

- ENG MASTERS OFF
- BRAKES ON ACCU ONLY

AFTER LANDING

When the aircraft has stopped :

- PARKING BRK ON
- ATC NOTIFY
- EVACUATION INITIATE
- ELT  CHECK EMITTING

If not, switch on the transmitter



ENG DUAL FAILURE - NO FUEL REMAINING (Cont'd)

■ IF DITCHING ANTICIPATED

APPROACH

- FOR LDG USE FLAP 3
Only slats extend, and slowly.
- MIN APPR SPEED 160 KT
- VAPP DETERMINE
Vapp is the maximum between Vref+30 knots / 160 knots :

Weight (1000 kg)	52	56	60	64	68	72	76	80	84	88	92	94
Vapp	160	160	160	160	163	167	171	174	178	181	185	187

- **At a suitable altitude (not below 3000 feet AGL), configure the aircraft for ditching (CONF 3 ; L/G UP)**

- L/G lever CHECK UP

AT 2000 FEET AGL

- CABIN NOTIFY FOR DITCHING
- DITCHING pushbutton ON
*In case of strong crosswind, ditch face to the wind.
In the absence of strong crosswind, prefer ditching parallel to the swell. Touchdown with approximately 11 degrees of pitch and minimum aircraft vertical speed.*

AT 500 FEET AGL

- BRACE FOR IMPACT ORDER

AT TOUCHDOWN

- ENG MASTERS OFF

AFTER DITCHING

- ATC (VHF 1) NOTIFY
- EVACUATION INITIATE
- ELT ◀ CHECK EMITTING
If not, switch on the transmitter

R

ENG DUAL FAILURE - NO FUEL REMAINING (Cont'd)

■ IF FORCED LANDING ANTICIPATED

APPROACH

- FOR LDG USE FLAP 3
Only slats extend, and slowly.
- MIN APPR SPEED 150 KT
- VAPP DETERMINE
Vapp is the maximum between Vref+25 knots / 150 knots.

Weight (1000 kg)	40	44	48	52	56	60	64	68	72	76
Vapp	150	150	150	150	150	150	154	158	162	166

● At a suitable altitude (not below 3000 feet AGL), configure the aircraft for landing (CONF 3 ; L/G DOWN)

● When in CONF 3 and VAPP

- GRAVITY GEAR EXTN handcrank PULL AND TURN
Flight controls revert to direct law at landing gear extension. Wait for CONF 3 and VAPP before extending the landing gear to enable the aircraft to be trimmed for approach. Disregard "USE MAN PITCH TRIM" on the PFD, because the stabilizer is frozen in the position where it was at, when the windmilling was insufficient to provide hydraulic power.

● When L/G downlocked

- L/G lever DOWN
- APPROACH SPEED ADJUST
Adjust the speed to the determined Vapp. Nevertheless, to reach the landing field/runway, the approach speed may be adjusted up to 200 knots (max speed with slats extended).
- GND SPLR ARM
- MAX BRK PR 1000 PSI

AT 2000 FEET AGL

- CABIN NOTIFY FOR LANDING

AT 500 FEET AGL

- BRACE FOR IMPACT ORDER

AT TOUCHDOWN

- ENG MASTERS OFF
- BRAKES ON ACCU ONLY

AFTER LANDING

● When the aircraft has stopped :

- PARKING BRK ON
- ATC NOTIFY
- EVACUATION INITIATE
- ELT  CHECK EMITTING
If not, switch on the transmitter



ENG DUAL FAILURE - NO FUEL REMAINING (Cont'd)

■ IF DITCHING ANTICIPATED

APPROACH

- FOR LDG USE FLAP 3
Only slats extend, and slowly.
- MIN APPR SPEED 150 KT
- VAPP DETERMINE
Vapp is the maximum between Vref+25 knots / 150 knots :

Weight (1000 kg)	40	44	48	52	56	60	64	68	72	76
Vapp	150	150	150	150	150	150	154	158	162	166

● At a suitable altitude (not below 3000 feet AGL), configure the aircraft for ditching (CONF 3 ; L/G UP)

- L/G lever CHECK UP

AT 2000 FEET AGL

- CABIN NOTIFY FOR DITCHING
- DITCHING pushbutton ON
*In case of strong crosswind, ditch face to the wind.
In the absence of strong crosswind, prefer ditching parallel to the swell. Touchdown with approximately 11 degrees of pitch and minimum aircraft vertical speed.*

AT 500 FEET AGL

- BRACE FOR IMPACT ORDER

AT TOUCHDOWN

- ENG MASTERS OFF

AFTER DITCHING

- ATC (VHF 1) NOTIFY
- EVACUATION INITIATE
- ELT ◀ CHECK EMITTING
If not, switch on the transmitter

R

IAE Eng. : V2522/V2524/V2527M

Mod : 20268

A319-131/-132/-133

ENG DUAL FAILURE – NO FUEL REMAINING (Cont'd)

■ IF FORCED LANDING ANTICIPATED

APPROACH

- FOR LDG USE FLAP 3
Only slats extend, and slowly.
- MIN APPR SPEED 150 KT
- VAPP DETERMINE
Vapp is the maximum between Vref+25 knots / 150 knots.

Weight (1000 kg)	40	44	48	52	56	60	64	68	72	76	78
Vapp	150	150	150	150	150	154	159	163	167	171	172

● At a suitable altitude (not below 3000 feet AGL), configure the aircraft for landing (CONF 3 ; L/G DOWN)

● When in CONF 3 and VAPP

- GRAVITY GEAR EXTN handcrank PULL AND TURN
Flight controls revert to direct law at landing gear extension. Wait for CONF 3 and VAPP before extending the landing gear to enable the aircraft to be trimmed for approach. Disregard "USE MAN PITCH TRIM" on the PFD, because the stabilizer is frozen in the position where it was at, when the windmilling was insufficient to provide hydraulic power.

● When L/G downlocked

- L/G lever DOWN
- APPROACH SPEED ADJUST
Adjust the speed to the determined Vapp. Nevertheless, to reach the landing field/runway, the approach speed may be adjusted up to 200 knots (max speed with slats extended).
- GND SPLR ARM
- MAX BRK PR 1000 PSI

AT 2000 FEET AGL

- CABIN NOTIFY FOR LANDING

AT 500 FEET AGL

- BRACE FOR IMPACT ORDER

AT TOUCHDOWN

- ENG MASTERS OFF
- BRAKES ON ACCU ONLY

AFTER LANDING

● When the aircraft has stopped :

- PARKING BRK ON
- ATC NOTIFY
- EVACUATION INITIATE
- ELT ◀ CHECK EMITTING

If not, switch on the transmitter



ENG DUAL FAILURE - NO FUEL REMAINING (Cont'd)

■ IF DITCHING ANTICIPATED

APPROACH

- FOR LDG USE FLAP 3
Only slats extend, and slowly.
- MIN APPR SPEED 150 KT
- VAPP DETERMINE
Vapp is the maximum between Vref+ 25 knots / 150 knots :

Weight (1000 kg)	40	44	48	52	56	60	64	68	72	76	78
Vapp	150	150	150	150	150	154	159	163	167	171	172

- **At a suitable altitude (not below 3000 feet AGL), configure the aircraft for ditching (CONF 3 ; L/G UP)**

- L/G lever CHECK UP

AT 2000 FEET AGL

- CABIN NOTIFY FOR DITCHING
- DITCHING pushbutton ON
*In case of strong crosswind, ditch face to the wind.
In the absence of strong crosswind, prefer ditching parallel to the swell. Touchdown with approximately 11 degrees of pitch and minimum aircraft vertical speed.*

AT 500 FEET AGL

- BRACE FOR IMPACT ORDER

AT TOUCHDOWN

- ENG MASTERS OFF

AFTER DITCHING

- ATC (VHF 1) NOTIFY
- EVACUATION INITIATE
- ELT ◀ CHECK EMITTING
If not, switch on the transmitter

R

DITCHING

This procedure applies when engines are running. If engines are not running, refer to the QRH "ENG DUAL FAILURE" (with or without fuel remaining) procedure, which has been amended to include the ditching procedure when the engines are not running.

PREPARATION

- ATC/TRANSPONDER (if available) NOTIFY/AS RQRD
*Notify ATC of the nature of the emergency encountered, and state intentions.
If not in contact with ATC, select transponder code A7700, or transmit the distress message on : (VHF) 121.5 MHZ or (HF) 2182 KHZ or 8364 KHZ.*
- CABIN and COCKPIT PREPARE
Loose equipment secured ; survival equipment prepared ; belts and shoulder harness locked.
- GPWS SYS OFF
- GPWS TERR OFF
- SIGNS ON
- GALLEY OFF
- LDG ELEV SELECT 00
- BARO SET
Omit normal approach and landing checklist.
- CREW MASKS/OXY SUPPLY (below FL100) OFF

APPROACH

- L/G lever UP
- SLATS and FLAPS MAX AVAIL

AT 2000 FEET AGL

- CAB PRESS MODE SEL CHECK AUTO
- BLEED (ENGs and APU) OFF
- CABIN NOTIFY FOR DITCHING
- DITCHING pushbutton ON
*In case of strong crosswind, ditch face to the wind.
In the absence of strong crosswind, prefer ditching parallel to the swell. Touchdown with approximately 11 degrees of pitch and minimum aircraft vertical speed.*

AT 500 FEET AGL

- BRACE FOR IMPACT ORDER

AT TOUCHDOWN

- ENG MASTERS OFF
- APU MASTER SW OFF

AFTER DITCHING

- ATC (VHF 1) NOTIFY
- FIRE pushbutton (ENG and APU) PUSH
- AGENTS (ENG and APU) DISCH
- EVACUATION INITIATE
- ELT CHECK EMITTING
If not, switch on the transmitter.

FORCED LANDING

This procedure applies when engines are running. If engines are not running, refer to the QRH "ENG DUAL FAILURE" (with or without fuel remaining) procedure, which has been amended to include the forced landing procedure, when the engines are not running.

PREPARATION

- ATC/TRANSPONDER (if available) NOTIFY/AS RQRD
*Notify ATC of the nature of the emergency encountered, and state intentions.
If not in contact with ATC, select transponder code A7700, or transmit the distress message on : (VHF) 121.5 MHZ or (HF) 2182 KHZ or 8364 KHZ.*
- CABIN and COCKPIT PREPARE
Loose equipment secured ; survival equipment prepared ; belts and shoulder harness locked.
- GPWS SYS OFF
- GPWS TERR OFF
- SIGNS ON
- GALLEY OFF
- LDG ELEV SET
- BARO SET
- Omit normal approach and landing checklist
- CREW MASKS/OXY SUPPLY (below FL100) OFF

APPROACH

- RAM AIR ON
- L/G lever DOWN
- SLATS AND FLAPS MAX AVAIL
- GND SPLR ARM
- MAX BRK PR 1000 PSI

AT 2000 FEET AGL

- CABIN NOTIFY FOR LANDING

AT 500 FEET AGL

- BRACE FOR IMPACT ORDER

AT TOUCHDOWN

- ENG MASTERS OFF
- APU MASTER SW OFF
- BRAKES ON ACCU ONLY

AFTER LANDING● **When aircraft has stopped :**

- PARKING BRK ON
- ATC (VHF1) NOTIFY
- FIRE pushbutton (ENG and APU) PUSH
- AGENTS (ENG and APU) DISCH
- EVACUATION INITIATE
- ELT CHECK EMITTING

If not, switch on the transmitter.

R

DITCHING

This procedure applies when engines are running. If engines are not running, refer to the QRH "ENG DUAL FAILURE" (with or without fuel remaining) procedure, which has been amended to include the ditching procedure when the engines are not running.

PREPARATION

- ATC/TRANSPONDER (if available) NOTIFY/AS RQRD
*Notify ATC of the nature of the emergency encountered, and state intentions.
If not in contact with ATC, select transponder code A7700, or transmit the distress message on : (VHF) 121.5 MHZ or (HF) 2182 KHZ or 8364 KHZ.*
- CABIN and COCKPIT PREPARE
Loose equipment secured ; survival equipment prepared ; belts and shoulder harness locked.
- GPWS SYS OFF
- GPWS TERR OFF
- SIGNS ON
- GALY & CAB OFF
- LDG ELEV SELECT 00
- BARO SET
Omit the normal approach and landing checklist.
- CREW MASKS/OXY SUPPLY (below FL100) OFF

APPROACH

- L/G lever UP
- SLATS and FLAPS MAX AVAIL

AT 2000 FEET AGL

- CAB PRESS MODE SEL CHECK AUTO
- BLEED (ENGs and APU) OFF
- CABIN NOTIFY FOR DITCHING
- DITCHING pushbutton ON
*In case of strong crosswind, ditch face to the wind.
In the absence of strong crosswind, prefer ditching parallel to the swell. Touchdown with approximately 11 degrees of pitch and minimum aircraft vertical speed.*

AT 500 FEET AGL

- BRACE FOR IMPACT ORDER

AT TOUCHDOWN

- ENG MASTERS OFF
- APU MASTER SW OFF

AFTER DITCHING

- ATC (VHF 1) NOTIFY
- FIRE pushbutton (ENG and APU) PUSH
- AGENTS (ENG and APU) DISCH
- EVACUATION INITIATE
- ELT CHECK EMITTING
If not, switch on the transmitter.

FORCED LANDING

This procedure applies when engines are running. If engines are not running, refer to the QRH "ENG DUAL FAILURE" (with or without fuel remaining) procedure, which has been amended to include the forced landing procedure, when the engines are not running.

PREPARATION

- ATC/TRANSPONDER (if available) NOTIFY/AS RORD
*Notify ATC of the nature of the emergency encountered, and state intentions.
If not in contact with ATC, select transponder code A7700, or transmit the distress message on : (VHF) 121.5 MHZ or (HF) 2182 KHZ or 8364 KHZ.*
- CABIN and COCKPIT PREPARE
Loose equipment secured ; survival equipment prepared ; belts and shoulder harness locked.
- GPWS SYS OFF
- GPWS TERR OFF
- SIGNS ON
- GALY & CAB OFF
- LDG ELEV SET
- BARO SET
Omit normal approach and landing checklist.
- CREW MASKS/OXY SUPPLY (below FL100) OFF

APPROACH

- RAM AIR ON
- L/G lever DOWN
- SLATS AND FLAPS MAX AVAIL
- GND SPLR ARM
- MAX BRK PR 1000 PSI

AT 2000 FEET AGL

- CABIN NOTIFY FOR LANDING

AT 500 FEET AGL

- BRACE FOR IMPACT ORDER

AT TOUCHDOWN

- ENG MASTERS OFF
- APU MASTER SW OFF
- BRAKES ON ACCU ONLY

AFTER LANDING

- **When aircraft has stopped :**
 - PARKING BRK ON
 - ATC (VHF1) NOTIFY
 - FIRE pushbutton (ENG and APU) PUSH
 - AGENTS (ENG and APU) DISCH
 - EVACUATION INITIATE
 - ELT CHECK EMITTING

If not, switch on the transmitter.

R

DITCHING

This procedure applies when engines are running. If engines are not running, refer to the QRH "ENG DUAL FAILURE" (with or without fuel remaining) procedure, which has been amended to include the ditching procedure when the engines are not running.

PREPARATION

- ATC/TRANSPONDER (if available) NOTIFY/AS RQRD
*Notify ATC of the nature of the emergency encountered, and state intentions.
If not in contact with ATC, select transponder code A7700, or transmit the distress message on : (VHF) 121.5 MHZ or (HF) 2182 KHZ or 8364 KHZ.*
- CABIN and COCKPIT PREPARE
Loose equipment secured ; survival equipment prepared ; belts and shoulder harness locked.
- GPWS SYS OFF
- GPWS TERR OFF
- SIGNS ON
- EMER EXIT LT ON
- COMMERCIAL OFF
- LDG ELEV SELECT 00
- BARO SET
Omit the normal approach and landing checklist.
- CREW MASKS/OXY SUPPLY (below FL100) OFF

APPROACH

- L/G lever UP
- SLATS and FLAPS MAX AVAIL

AT 2000 FEET AGL

- CAB PRESS MODE SEL CHECK AUTO
- BLEED (ENGs and APU) OFF
- CABIN NOTIFY FOR DITCHING
- DITCHING pushbutton ON
*In case of strong crosswind, ditch face to the wind.
In the absence of strong crosswind, prefer ditching parallel to the swell. Touchdown with approximately 11 degrees of pitch and minimum aircraft vertical speed.*

AT 500 FEET AGL

- BRACE FOR IMPACT ORDER

AT TOUCHDOWN

- ENG MASTERS OFF
- APU MASTER SW OFF

AFTER DITCHING

- ATC (VHF 1) NOTIFY
- FIRE pushbutton (ENG and APU) PUSH
- AGENTS (ENG and APU) DISCH
- EVACUATION INITIATE
- ELT CHECK EMITTING
If not, switch on the transmitter.

FORCED LANDING

This procedure applies when engines are running. If engines are not running, refer to the QRH "ENG DUAL FAILURE" (with or without fuel remaining) procedure, which has been amended to include the forced landing procedure, when the engines are not running.

PREPARATION

- ATC/TRANSPONDER (if available) NOTIFY/AS RORD
*Notify ATC of the nature of the emergency encountered, and state intentions.
If not in contact with ATC, select transponder code A7700, or transmit the distress message on : (VHF) 121.5 MHZ or (HF) 2182 KHZ or 8364 KHZ.*
- CABIN and COCKPIT PREPARE
Loose equipment secured ; survival equipment prepared ; belts and shoulder harness locked.
- GPWS SYS OFF
- GPWS TERR OFF
- SIGNS ON
- EMER EXIT LT ON
- COMMERCIAL OFF
- LDG ELEV SET
- BARO SET
Omit normal approach and landing checklist.
- CREW MASKS/OXY SUPPLY (below FL100) OFF

APPROACH

- RAM AIR ON
- L/G lever DOWN
- SLATS AND FLAPS MAX AVAIL
- GND SPLR ARM
- MAX BRK PR 1000 PSI

AT 2000 FEET AGL

- CABIN NOTIFY FOR LANDING

AT 500 FEET AGL

- BRACE FOR IMPACT ORDER

AT TOUCHDOWN

- ENG MASTERS OFF
- APU MASTER SW OFF
- BRAKES ON ACCU ONLY

AFTER LANDING

- **When aircraft has stopped :**
 - PARKING BRK ON
 - ATC (VHF1) NOTIFY
 - FIRE pushbutton (ENG and APU) PUSH
 - AGENTS (ENG and APU) DISCH
 - EVACUATION INITIATE
 - ELT CHECK EMITTING
If not, switch on the transmitter.

EMER DESCENT

IMMEDIATE ACTIONS

- R
- CREW OXY MASKS ON
 - The recommendation is to descend with the AP engaged :
 - . Turn the ALT selector knob and pull.
 - . Turn the HDG selector knob and pull.
 - . Adjust the target SPD/MACH.
 - THR LEVERS (if A/THR not engaged) IDLE
 - SPD BRK FULL

Extension of the speedbrakes will significantly increase Vls.

To avoid AP disconnection and automatic retraction of the speedbrakes, due to possible activation of Angle-of-Attack protection, allow the speed to increase before starting to use the speedbrakes.

WHEN DESCENT ESTABLISHED

EMER DESCENT FL100, or minimum allowable altitude.

- SPEED MAX/APPROPRIATE

CAUTION

Descend at the maximum appropriate speed. If structural damage is suspected, use the flight controls with care and reduce speed as appropriate.

Landing gear may be extended below 25,000 feet. In such a case, speed must be reduced to VLO/VLE.

NOTE : *The recommendation is to descend with the autopilot engaged.*

Use of the autopilot is also permitted in EXPEDITE mode (\leq).

- SIGNS ON
- ENG MODE SEL IGN
- ATC NOTIFY

To save oxygen, set the oxygen diluter selector to the N position. If the oxygen diluter selector remains at 100 %, the quantity of oxygen may not be sufficient for the entire emergency descent profile.

● IF CAB ALT > 14000 feet :

- PAX OXY MASKS MAN ON

Confirm that passenger masks are released.

CONTENTS

■	<u>PRESS</u>	
	. CABIN OVERPRESSURE	2.01
■	<u>AUTO FLIGHT</u>	
	. LOSS OF FMS DATA IN DESCENT/APPROACH (SEVERE RESET)	2.02B
	. LOW ENERGY WARNING	2.03
■	<u>ELEC</u>	
	. FLT ON BAT ONLY	2.03
■	<u>EQUIPMENT</u>	
	. COCKPIT DOOR FAULT ◀	2.03
■	<u>F/CTL</u>	
	. LANDING WITH SLATS or FLAPS JAMMED	2.04
	. RUDDER JAM	2.06
	. STABILIZER JAM	2.07
■	<u>FUEL</u>	
	. FUEL LEAK	2.08
	. FUEL IMBALANCE	2.09
	. GRVTY FUEL FEEDING	2.09
■	<u>A. ICE</u>	
	. DOUBLE PROBE HEAT FAIL	2.10
■	<u>INDICATING/RECORDING</u>	
	. DISPLAY UNIT FAILURE	2.10
	. ECAM SINGLE DISPLAY	2.10
■	<u>LANDING GEAR</u>	
	. RESIDUAL BRAKING PROC	2.10B
	. L/G GRAVITY EXTENSION	2.11
	. LDG WITH ABNORMAL L/G	2.12
■	<u>NAV</u>	
R	. ADR DISAGREE	2.14
R	. UNRELIABLE SPEED INDICATION/ADR CHECK PROC	2.15
	. FM / GPS POS DISAGREE (◀)	2.19
	. ADR 1 + 2 + 3 FAULT	2.20
	. IR ALIGNMENT IN ATT MODE	2.21
■	<u>PNEUMATIC</u>	
	. DUAL BLEED FAULT	2.02

CONTENTS

■	PRESS	
	. CABIN OVERPRESSURE	2.01
■	AUTO FLIGHT	
	. LOSS OF FMS DATA IN DESCENT/APPROACH (SEVERE RESET)	2.02B
	. LOW ENERGY WARNING	2.03
■	EQUIPMENT	
	. COCKPIT DOOR FAULT ◀	2.03
■	F/CTL	
	. LANDING WITH SLATS or FLAPS JAMMED	2.04
	. RUDDER JAM	2.06
	. STABILIZER JAM	2.07
■	FUEL	
	. FUEL LEAK	2.08
	. FUEL IMBALANCE	2.09
	. GRVTY FUEL FEEDING	2.09
■	A. ICE	
	. DOUBLE STAT (AOA) HEAT FAIL	2.10
■	INDICATING/RECORDING	
	. DISPLAY UNIT FAILURE	2.10
	. ECAM SINGLE DISPLAY	2.10A
■	LANDING GEAR	
	. RESIDUAL BRAKING PROC	2.10B
	. L/G GRAVITY EXTENSION	2.11
	. LDG WITH ABNORMAL L/G	2.12
■	NAV	
R	. ADR DISAGREE	2.14
R	. UNRELIABLE SPEED INDICATION/ADR CHECK PROC	2.15
	. FM / GPS POS DISAGREE (◀)	2.19
	. ADR 1 + 2 + 3 FAULT	2.20
	. IR ALIGNMENT IN ATT MODE	2.21
■	PNEUMATIC	
	. DUAL BLEED FAULT	2.02

CONTENTS

■	<u>PRESS</u>	
	. CABIN OVERPRESSURE	2.01
■	<u>AUTO FLIGHT</u>	
	. LOSS OF FMS DATA IN DESCENT/APPROACH (SEVERE RESET)	2.02B
	. LOW ENERGY WARNING	2.03
■	<u>EQUIPMENT</u>	
	. COCKPIT DOOR FAULT ◀	2.03
■	<u>F/CTL</u>	
	. LANDING WITH SLATS or FLAPS JAMMED	2.04
	. RUDDER JAM	2.06
	. STABILIZER JAM	2.07
■	<u>FUEL</u>	
	. FUEL LEAK	2.08
	. FUEL IMBALANCE	2.09
	. GRVTY FUEL FEEDING	2.09
■	<u>A. ICE</u>	
	. DOUBLE STAT (AOA) HEAT FAIL	2.10
■	<u>INDICATING/RECORDING</u>	
	. DISPLAY UNIT FAILURE	2.10
	. ECAM SINGLE DISPLAY	2.10A
■	<u>LANDING GEAR</u>	
	. RESIDUAL BRAKING PROC	2.10B
	. ASYMMETRIC BRAKING	2.11
	. L/G GRAVITY EXTENSION	2.11
	. LDG WITH ABNORMAL L/G	2.12
■	<u>NAV</u>	
R	. ADR DISAGREE	2.14
R	. UNRELIABLE SPEED INDICATION/ADR CHECK PROC	2.15
	. FM / GPS POS DISAGREE (◀)	2.19
	. ADR 1 + 2 + 3 FAULT	2.20
	. IR ALIGNMENT IN ATT MODE	2.21
■	<u>PNEUMATIC</u>	
	. DUAL BLEED FAULT	2.02

CONTENTS

■	PRESS	
	. CABIN OVERPRESSURE	2.01
■	AUTO FLIGHT	
	. LOSS OF FMS DATA IN DESCENT/APPROACH (SEVERE RESET)	2.02B
	. LOW ENERGY WARNING	2.03
■	EQUIPMENT	
	. COCKPIT DOOR FAULT ◀	2.03
■	F/CTL	
	. LANDING WITH SLATS or FLAPS JAMMED	2.04
	. RUDDER JAM	2.06
	. STABILIZER JAM	2.07
■	FUEL	
	. FUEL LEAK	2.08
	. FUEL IMBALANCE	2.09
	. GRVTY FUEL FEEDING	2.09
	. ACT UNUSABLE PROC	2.09A
■	A. ICE	
	. DOUBLE STAT (AOA) HEAT FAIL	2.10
■	INDICATING/RECORDING	
	. DISPLAY UNIT FAILURE	2.10
	. ECAM SINGLE DISPLAY	2.10A
■	LANDING GEAR	
	. RESIDUAL BRAKING PROC	2.10B
	. L/G GRAVITY EXTENSION	2.11
	. LDG WITH ABNORMAL L/G	2.12
■	NAV	
R	. ADR DISAGREE	2.14
R	. UNRELIABLE SPEED INDICATION/ADR CHECK PROC	2.15
	. FM / GPS POS DISAGREE (◀)	2.19
	. ADR 1 + 2 + 3 FAULT	2.20
	. IR ALIGNMENT IN ATT MODE	2.21
■	PNEUMATIC	
	. DUAL BLEED FAULT	2.02

CONTENTS

■	<u>PRESS</u>	
	. CABIN OVERPRESSURE	2.01
■	<u>AUTO FLIGHT</u>	
	. LOSS OF FMS DATA IN DESCENT/APPROACH (SEVERE RESET)	2.02B
	. LOW ENERGY WARNING	2.03
■	<u>EQUIPMENT</u>	
	. COCKPIT DOOR FAULT ◀	2.03
■	<u>F/CTL</u>	
	. LANDING WITH SLATS or FLAPS JAMMED	2.04
	. RUDDER JAM	2.06
	. STABILIZER JAM	2.07
■	<u>FUEL</u>	
	. FUEL LEAK	2.08
	. GRVTY FUEL FEEDING	2.09
	. FUEL IMBALANCE	2.09
	. ACT XFR FAULT PROC	2.09A
	. ACT SYSTEM FAULT PROC	2.09A
	. FWD ACT ISOLATED PROC	2.09B
	. ZFCG GRAPHS	2.09C
■	<u>A. ICE</u>	
	. DOUBLE STAT (AOA) HEAT FAIL	2.10
■	<u>INDICATING/RECORDING</u>	
	. DISPLAY UNIT FAILURE	2.10
	. ECAM SINGLE DISPLAY	2.10A
■	<u>LANDING GEAR</u>	
	. RESIDUAL BRAKING PROC	2.10B
	. L/G GRAVITY EXTENSION	2.11
	. LDG WITH ABNORMAL L/G	2.12
■	<u>NAV</u>	
R	. ADR DISAGREE	2.14
R	. UNRELIABLE SPEED INDICATION/ADR CHECK PROC	2.15
	. ADR 1 + 2 + 3 FAULT	2.20
	. FM / GPS POS DISAGREE (◀)	2.19
	. IR ALIGNMENT IN ATT MODE	2.21
■	<u>PNEUMATIC</u>	
	. DUAL BLEED FAULT	2.02

■ POWERPLANT

. ENG RELIGHT (IN FLIGHT)	2.22
. ENG 1(2) STALL	2.23
. APPROACH WITH ONE ENGINE INOPERATIVE	2.23
. ENG TAILPIPE FIRE	2.23
. HIGH ENGINE VIBRATION	2.24

■ MISCELLANEOUS

. OVERWEIGHT LANDING	2.25
. WINDSHIELD/WINDOW CRACKED/ARCING	2.26
. VOLCANIC ASH ENCOUNTER	2.26
. BOMB ON BOARD	2.27
. VAPP DETERMINATION	2.31
. APPR SPD-LDG DIST CORRECTIONS FOR FAILURES	2.32
. TRIPPED C/B RE-ENGAGEMENT	2.34
. COMPUTER RESET	2.34
. ECAM ADVISORY CONDITIONS	2.40
. TAILSTRIKE	2.42
R . CIRCLING APPROACH WITH ONE ENGINE	
R INOPERATIVE	2.43

CABIN OVERPRESSURE

Apply the following procedure (not displayed on ECAM) in case of total loss of the cabin pressure control leading to overpressure.

- PACK 1 or 2 OFF
- BLOWER + EXTRACT OVRD
Cabin air is extracted overboard.
- ΔP FREQUENTLY MONITOR

● **If $\Delta P > 9$ PSI**

- PACK 1 + 2 OFF
LAND ASAP

Before 10 minutes from landing :

- PACK 1 + 2 OFF
- BLOWER + EXTRACT AUTO

CAUTION

Check that ΔP is zero before opening the doors.

AIR DUAL BLEED FAULT

■ **If ENG 1 BLEED was lost due to a :**

LEAK on side 1

ENG 1 FIRE

Start Air Valve 1 failed open.

– DESCENT TO FL100/MEA INITIATE

Descend rapidly to FL100/MEA, to prevent excessive cabin altitude.

AVOID ICING CONDITIONS

■ **If ENG 2 BLEED was lost due to a :**

LEAK on side 2

ENG 2 FIRE

Start Air Valve 2 failed open.

– X BLEED CHECK CLOSED

– DESCENT TO FL200/MEA INITIATE

Descend rapidly to FL200, to recover the bleed supply from the APU.

– APU START

Start the APU during the descent.

● **AT, OR BELOW, FL200 :**

– WING A.ICE OFF

APU BLEED must not be used for wing anti-ice.

– APU BLEED ON

MAX FL200

AVOID ICING CONDITIONS

■ **In all other cases :**

– DESCENT INITIATE

Descend rapidly to FL200, so that the bleed supply may be supplied by the APU, if the bleed system recovery is not successful.

● **If both packs are available :**

If both packs are operative, it can be suspected that the second bleed system failed due to excessive demand. Recovery of the second failed engine bleed may be attempted.

■ **If ENG 1 BLEED is lost first :**

– PACK 1 OFF

– ENGINE 2 BLEED ON

■ **If ENG 2 BLEED is lost first :**

– PACK 2 OFF

– ENGINE 1 BLEED ON



R

R

R

AIR DUAL BLEED FAULT (CONT'D)

- If engine bleed recovery was not successful, or if one pack is inoperative :

- X BLEED CHECK OPEN
- DESCENT TO FL200/MEA CONTINUE
Descend rapidly to FL200, to recover the bleed supply from the APU.
- APU START
Start the APU during the descent.

- AT, OR BELOW, FL200 :

- WING A.ICE OFF
APU BLEED must not be used for wing anti-ice.
 - APU BLEED ON
- MAX FL200
AVOID ICING CONDITIONS

LOSS OF FMS DATA IN DESCENT/APPROACH (SEVERE RESET)

AP/FD lateral and vertical selected modes, and A/THR, are available immediately after the reset. If necessary, the pilot may perform the FCU selections for short-term navigation.

When the FMS has automatically recovered :

- The database cycle may have changed
- The FMGS does not autotune the ILS and ADF
- The FMS position bias is lost
- Lateral and vertical managed modes cannot re-engage
- The "CAB PR LDG ELEV FAULT" message is displayed on the ECAM
- A "MAP NOT AVAIL" message may be displayed on one ND.

With respect to the Auto Flight System, and depending on when the flight plan is lost, the following two procedures list the actions to be performed, in their order of priority :

■ INITIAL APPROACH OR CLOSE TO ILS INTERCEPTION

● **When the system has recovered :**

- Access the RAD NAV page, and manually tune the ILS (preferably using Ident). Enter the ILS course, if a frequency has been entered.
- Fly in selected speed.

NOTE : – LOC and G/S guidance modes are available.
 – VLS speed is still available and displayed on the PFD.
 – Missed approach trajectory is not available.

■ DESCENT or TERMINAL AREA

● **When the system has recovered :**

- Select the initial database
- Perform DIR TO a downpath waypoint. Select heading, if required.
- Perform a LAT REV at the downpath waypoint and redefine the DESTINATION in the NEW DEST field.
- Redefine the arrival and/or the approach procedure.
- Select the FUEL PRED page, and enter the GW.
- Activate the APPROACH phase.

Enter destination data on the PERF APPR page, as required. Managed speed is available.

R **LOSS OF FMS DATA IN DESCENT/APPROACH (SEVERE RESET)**

AP/FD lateral and vertical selected modes, and A/THR, are available immediately after the reset. If necessary, the pilot may perform the FCU selections for short-term navigation.

When the FMS has automatically recovered (i.e. when the FMGC prompt is available and selectable on the MCDU MENU page) :

- The FMGS does not autotune the ILS and ADF
- The FMS position bias is lost
- Lateral and vertical managed modes cannot re-engage
- The "CAB PR LDG ELEV FAULT" message is displayed on the ECAM
- A "MAP NOT AVAIL" message may be displayed on one ND.

With respect to the Auto Flight System, and depending on when the flight plan is lost, the following two procedures list the actions to be performed, in their order of priority :

■ INITIAL APPROACH OR CLOSE TO ILS INTERCEPTION

● **When the system has recovered :**

- Access the RAD NAV page, and manually tune the ILS (preferably using Ident). Enter the ILS course, if a frequency has been entered.
- Fly in selected speed.

NOTE : - LOC and G/S guidance modes are available.

- VLS speed is still available and displayed on the PFD.
- Missed approach trajectory is not available.

■ DESCENT or TERMINAL AREA

● **When the system has recovered :**

- Perform DIR TO a downpath waypoint. Select heading, if required.
- Perform a LAT REV at the downpath waypoint and redefine the DESTINATION in the NEW DEST field.
- Redefine the arrival and/or the approach procedure.
- Select the FUEL PRED page, and enter the GW.
- Activate the APPROACH phase.

Enter destination data on the PERF APPR page, as required. Managed speed is available.

LOW ENERGY WARNING

The "SPEED SPEED SPEED" synthetic voice is triggered every 5 seconds, whenever the aircraft energy goes below a threshold under which thrust shall be increased to recover a positive flight path angle.

– THR LEVERS PUSH

Increase the thrust until the warning disappears.

FLT ON BAT ONLY

Flight time on batteries only may be increased to at least 30 minutes, as follows :

– ENG MODE SEL NORM

– ANTI ICE PITOT 1 C/B (D02) PULL

– 26 V ADIRU 1 C/B (F07) PULL

CM 1 altitude, speed, and vertical speed indication on the PFD are lost. Use standby instruments.

● **7 minutes before landing :**

– ANTI ICE PITOT 1 C/B (D02) RESET

● **After 1 minute :**

– CAUTION

This time delay is necessary to ensure reliable speed information, even in icing conditions when the ADIRU is reset to ON.

– 26 V ADIRU 1 C/B (F07) RESET

COCKPIT DOOR FAULT

This procedure should be applied, if the Cockpit Door Locking System (CDLS) fails. This failure is indicated when the FAULT light on the center pedestal's CKPT DOOR panel comes on.

– CKPT DOOR CONT PANEL CHECK

This panel is located on the overhead panel. It is used to identify the faulty CDLS item, and to verify the status of the pressure sensors and the three electrical latches (referred to as strikes).

● **If two or more electrical latches (strikes) are faulty :**

The cockpit door is not intrusion-proof.

The system may be recovered by performing the following steps :

– Cockpit door OPEN

– Cockpit door toggle switch SET to UNLOCK

After 10 seconds :

– Cockpit door toggle switch SET to NORM

● **If two pressure sensors are faulty :**

Automatic latch release is not available, in case of cockpit decompression.

● **If no LED on the CKPT DOOR CONT panel is on :**

The CDLS control unit is faulty, therefore, the cockpit door might unlock automatically.

If it does not, consider using the mechanical override system to unlock the door.

NOTE : In the case of a DC BUS 2 fault, no FAULT indication appears on the center pedestal's CKPT DOOR panel. The CDLS is not electrically-supplied, and is inoperative.

LANDING WITH SLATS OR FLAPS JAMMED

– LANDING CONF CONF 3

■ **Repeat the following until landing configuration is reached :**

– SPEED SEL VFE NEXT – 5 KT

Decelerate towards VFE NEXT – 5 KT, but not below VLS. If turbulence, the pilot may decide to decelerate to a lower speed (not below VLS) to avoid VFE exceedance.

NOTE : . Autopilot may be used down to 500 feet AGL. As it is not tuned for abnormal configurations, its behavior can be less than optimum and must be monitored.

. Approach with selected speed is recommended.

. A/THR is recommended, except in the case of a G+B SYS LO PR warning.

. VLS, displayed on the PFD, and OVERSPEED warning, are computed according to the actual flaps/slats position.

. VFE and VFE NEXT are displayed on the PFD according to the FLAPS' lever position. If not displayed, use the placard speeds.

. If VLS is greater than VFE NEXT (overweight landing), FLAPS lever can be set to the next required position while speed is reduced to follow VLS reduction, as surfaces extend. The VFE warning threshold should not be triggered.

In this case, disconnect the A/THR. A/THR can be re-engaged when landing configuration is established.

As speed reduces through VFE NEXT :

– FLAPS LEVER ONE STEP DOWN

● **When landing configuration is established :**

– DECELERATE TO CALCULATED APPROACH SPEED IN FINAL APPROACH

FOR GO AROUND

The table on page 2.05 provides the MAX SPEEDS for abnormal configurations.

■ **IF SLATS FAULT**

● **FOR CIRCUIT**

– MAINTAIN SLAT/FLAP CONFIGURATION

– Recommended speed : MAX SPEED – 10 KT

● **FOR DIVERSION**

– SELECT CLEAN CONFIGURATION

Recommended speed for flaps retraction is between MAX SPEED - 10 KT and MAX SPEED.

– Recommended speed : MAX SPEED – 10 KT

■ **IF FLAPS FAULT**

● **FOR CIRCUIT**

– MAINTAIN SLAT/FLAP CONFIGURATION

– Recommended speed : MAX SPEED – 10 KT

● **FOR DIVERSION**

● **If Flaps jammed at 0**

– SELECT CLEAN CONFIGURATION

NOTE : *Recommended speed for slats retraction is between MAX SPEED - 10 knots and max speed of actual slat/flap position.*

– NORMAL OPERATING SPEEDS

● **If Flaps jammed > 0**

– MAINTAIN SLAT/FLAP CONFIGURATION

– Recommended speed : MAX SPEED – 10 KT

NOTE : . *In case of go-around with CONF FULL selected, the L/G NOT DOWN warning is triggered at landing gear retraction.*

. *In some cases, MAX SPEED - 10KT may be a few knots higher than the VFE. In this situation, pilots may follow the VFE.*



LOW ENERGY WARNING

The "SPEED SPEED SPEED" synthetic voice is triggered every 5 seconds, whenever the aircraft energy goes below a threshold under which thrust shall be increased to recover a positive flight path angle.

- THR LEVERS PUSH

Increase the thrust until the warning disappears.

COCKPIT DOOR FAULT

This procedure should be applied, if the Cockpit Door Locking System (CDLS) fails. This failure is indicated when the FAULT light on the center pedestal's CKPT DOOR panel comes on.

- CKPT DOOR CONT PANEL CHECK
This panel is located on the overhead panel. It is used to identify the faulty CDLS item, and to verify the status of the pressure sensors and the three electrical latches (referred to as strikes).

- **If two or more electrical latches (strikes) are faulty :**

The cockpit door is not intrusion-proof.

The system may be recovered by performing the following steps :

- Cockpit door OPEN
- Cockpit door toggle switch SET to UNLOCK

After 10 seconds :

- Cockpit door toggle switch SET to NORM

- **If two pressure sensors are faulty :**

Automatic latch release is not available, in case of cockpit decompression.

- **If no LED on the CKPT DOOR CONT panel is on :**

The CDLS control unit is faulty, therefore, the cockpit door might unlock automatically.

If it does not, consider using the mechanical override system to unlock the door.

NOTE : In the case of a DC BUS 2 fault, no FAULT indication appears on the center pedestal's CKPT DOOR panel. The CDLS is not electrically-supplied, and is inoperative.

LANDING WITH SLATS OR FLAPS JAMMED

– LANDING CONF CONF 3

■ **Repeat the following until landing configuration is reached :**

– SPEED SEL VFE NEXT – 5 KT

Decelerate towards VFE NEXT – 5 KT, but not below VLS. If turbulence, the pilot may decide to decelerate to a lower speed (not below VLS) to avoid VFE exceedance.

NOTE : . Autopilot may be used down to 500 feet AGL. As it is not tuned for abnormal configurations, its behavior can be less than optimum and must be monitored.

. Approach with selected speed is recommended.

. A/THR is recommended, except in the case of a G+B SYS LO PR warning.

. VLS, displayed on the PFD, and OVERSPEED warning, are computed according to the actual flaps/slats position.

. VFE and VFE NEXT are displayed on the PFD according to the FLAPS' lever position. If not displayed, use the placard speeds.

. If VLS is greater than VFE NEXT (overweight landing), FLAPS lever can be set to the next required position while speed is reduced to follow VLS reduction, as surfaces extend. The VFE warning threshold should not be triggered.

In this case, disconnect the A/THR. A/THR can be re-engaged when landing configuration is established.

As speed reduces through VFE NEXT :

– FLAPS LEVER ONE STEP DOWN

● **When landing configuration is established :**

– DECELERATE TO CALCULATED APPROACH SPEED IN FINAL APPROACH

FOR GO AROUND

The table on page 2.05 provides the MAX SPEEDS for abnormal configurations.

■ **IF SLATS FAULT**

● **FOR CIRCUIT**

– MAINTAIN SLAT/FLAP CONFIGURATION

– Recommended speed : MAX SPEED – 10 KT

● **FOR DIVERSION**

– SELECT CLEAN CONFIGURATION

Recommended speed for flaps retraction is between MAX SPEED - 10 KT and MAX SPEED.

– Recommended speed : MAX SPEED – 10 KT

■ **IF FLAPS FAULT**

● **FOR CIRCUIT**

– MAINTAIN SLAT/FLAP CONFIGURATION

– Recommended speed : MAX SPEED – 10 KT

● **FOR DIVERSION**

● **If Flaps jammed at 0**

– SELECT CLEAN CONFIGURATION

NOTE : *Recommended speed for slats retraction is between MAX SPEED - 10 knots and max speed of actual slat/flap position.*

– NORMAL OPERATING SPEEDS

● **If Flaps jammed > 0**

– MAINTAIN SLAT/FLAP CONFIGURATION

– Recommended speed : MAX SPEED – 10 KT

NOTE : . *In case of go-around with CONF FULL selected, the L/G NOT DOWN warning is triggered at landing gear retraction.*

. *In some cases, MAX SPEED - 10KT may be a few knots higher than the VFE. In this situation, pilots may follow the VFE.*



LOW ENERGY WARNING

The "SPEED SPEED SPEED" synthetic voice is triggered every 5 seconds whenever the aircraft energy goes below a threshold under which thrust shall be increased to recover a positive flight path angle.

- THR LEVERS PUSH

Increase the thrust until the warning disappears.

COCKPIT DOOR FAULT

This procedure should be applied, if the Cockpit Door Locking System (CDLS) fails. This failure is indicated when the FAULT light on the center pedestal's CKPT DOOR panel comes on. In case of a DC BUS 2 loss, the cockpit door also fails, but there is no FAULT indication.

- CKPT DOOR CONT NORMAL PANEL CHECK

This panel is located on the left-hand side of the overhead panel. It is used to identify the faulty CDLS item, and to verify the status of the normal panel's pressure sensors and the status of the three electrical latches (referred to as strikes).

- **If two or more electrical latches (strikes) are faulty :**

The cockpit door is not intrusion-proof.

The system may be recovered by performing the following steps :

- Cockpit door OPEN
- Cockpit door toggle switch SET to UNLOCK

After 10 seconds :

- Cockpit door toggle switch SET to NORM

- **If no LED on the CKPT DOOR CONT panel is on, or if two pressure sensors are faulty :**

- LKG SYS switch BACKUP

When the CDLS is switched to the Backup Control Unit (BCU), the FAULT light goes off and the BCU controls the CDLS. Therefore :

- **If entry is requested :**

Identify the person that is requesting entry.

- **If entry is authorized :**

- CKPT DOOR BKUP CTL pb PRESS and MAINTAIN

This unlocks the cockpit door, which can be pushed open from the cabin side.

NOTE : *As emergency access to the cockpit is not available when the BCU controls the CDLS, it is recommended that at least two crewmembers remain in the cockpit during that time.*

LANDING WITH SLATS OR FLAPS JAMMED

– LANDING CONF CONF 3

■ **Repeat the following until landing configuration is reached :**

– SPEED SEL VFE NEXT – 5 KT

Decelerate towards VFE NEXT – 5 KT, but not below VLS. If turbulence, the pilot may decide to decelerate to a lower speed (not below VLS) to avoid VFE exceedance.

NOTE : . Autopilot may be used down to 500 feet AGL. As it is not tuned for abnormal configurations, its behavior can be less than optimum and must be monitored.

. Approach with selected speed is recommended.

. A/THR is recommended, except in the case of a G+B SYS LO PR warning.

. VLS, displayed on the PFD, and OVERSPEED warning, are computed according to the actual flaps/slats position.

. VFE and VFE NEXT are displayed on the PFD according to the FLAPS' lever position. If not displayed, use the placard speeds.

. If VLS is greater than VFE NEXT (overweight landing), FLAPS lever can be set to the next required position while speed is reduced to follow VLS reduction, as surfaces extend. The VFE warning threshold should not be triggered.

In this case, disconnect the A/THR. A/THR can be re-engaged when landing configuration is established.

As speed reduces through VFE NEXT :

– FLAPS LEVER ONE STEP DOWN

● **When landing configuration is established :**

– DECELERATE TO CALCULATED APPROACH SPEED IN FINAL APPROACH

FOR GO AROUND

The table on page 2.05 provides the MAX SPEEDS for abnormal configurations.

■ **IF SLATS FAULT**

● **FOR CIRCUIT**

– MAINTAIN SLAT/FLAP CONFIGURATION

– Recommended speed : MAX SPEED – 10 KT

● **FOR DIVERSION**

– SELECT CLEAN CONFIGURATION

Recommended speed for flaps retraction is between MAX SPEED - 10 KT and MAX SPEED.

– Recommended speed : MAX SPEED – 10 KT

■ **IF FLAPS FAULT**

● **FOR CIRCUIT**

– MAINTAIN SLAT/FLAP CONFIGURATION

– Recommended speed : MAX SPEED – 10 KT

● **FOR DIVERSION**

● **If Flaps jammed at 0**

– SELECT CLEAN CONFIGURATION

NOTE : *Recommended speed for slats retraction is between MAX SPEED - 10 knots and max speed of actual slat/flap position.*

– NORMAL OPERATING SPEEDS

● **If Flaps jammed > 0**

– MAINTAIN SLAT/FLAP CONFIGURATION

– Recommended speed : MAX SPEED – 10 KT

NOTE : . *In case of go-around with CONF FULL selected, the L/G NOT DOWN warning is triggered at landing gear retraction.*

. *In some cases, MAX SPEED - 10KT may be a few knots higher than the VFE. In this situation, pilots may follow the VFE.*



LANDING WITH SLATS OR FLAPS JAMMED (cont'd)

MAX SPEED

Flaps Slats	F = 0	0 < F ≤ 1	1 < F ≤ 2	2 < F ≤ 3	F > 3
S = 0	NO LIMITATION	215 kt	200 kt	185 kt	177 kt (Not allowed)
0 < S ≤ 1	230 kt				
1 < S ≤ 3	200 kt		200 kt	185 kt	177 kt
S > 3	177 kt		177 kt	177 kt	177 kt

— CAUTION —

For flight with SLATS or FLAPS extended, fuel consumption is increased. Refer to fuel flow indication.

As a guideline, determine the fuel consumption in clean configuration at same altitude without airspeed limitation (e.g. from ALTERNATE FLIGHT PLANNING tables) and multiply this result by 1.6 (SLATS EXTENDED) or 1.8 (FLAPS EXTENDED) or 2 (SLATS and FLAPS EXTENDED) to give the fuel consumption required to reach the destination in the current configuration.

F/CTL RUDDER JAM

Rudder jamming may be detected by undue (and adverse) pedal movement during rolling maneuvers.

This is because the yaw damper orders can no longer be sent to the rudder, but are fed back to the pedals.

Use the ECAM F/CTL page for a visual check of the rudder position.

FOR APPROACH

- AVOID LANDING WITH CROSSWIND from the side where the rudder is deflected.
- MAX CROSSWIND 15 KT
- FOR LANDING USE NORMAL CONF
- SPEED and TRAJECTORY STABILIZE ASAP

ON GROUND

- DIFFERENTIAL BRAKING USE ASAP

Do not use asymmetric thrust reverse.

Use nosewheel steering handle below 70 knots.

LANDING WITH SLATS OR FLAPS JAMMED (Cont'd)

MAX SPEED

Flaps Slats	F = 0	0 < F ≤ 1	1 < F ≤ 2	2 < F ≤ 3	F > 3
S = 0	NO LIMITATION	225 kt	215 kt	195 kt	190 kt (Not allowed)
0 < S ≤ 1	235 kt				
1 < S ≤ 3	215 kt		215 kt	195 kt	190 kt
S > 3	190 kt		190 kt	190 kt	190 kt

— CAUTION —

For flight with SLATS or FLAPS extended, fuel consumption is increased. Refer to the fuel flow indication.

As a guideline, determine the fuel consumption in clean configuration at same altitude without airspeed limitation (e.g. from ALTERNATE FLIGHT PLANNING tables) and multiply this result by 1.6 (SLATS EXTENDED) or 1.8 (FLAPS EXTENDED) or 2 (SLATS and FLAPS EXTENDED) to give the fuel consumption required to reach the destination in the current configuration.

F/CTL RUDDER JAM

Rudder jamming may be detected by undue (and adverse) pedal movement during rolling maneuvers.

This is because the yaw damper orders can no longer be sent to the rudder, but are fed back to the pedals.

Use the ECAM F/CTL page for a visual check of the rudder position.

FOR APPROACH

- AVOID LANDING WITH CROSSWIND from the side where the rudder is deflected.
- MAX CROSSWIND 15 KT
- FOR LANDING USE NORMAL CONF
- SPEED and TRAJECTORY STABILIZE ASAP

ON GROUND

- DIFFERENTIAL BRAKING USE ASAP

Do not use asymmetric thrust reverse.

Use nosewheel steering handle below 70 knots.

STABILIZER JAM

The system may not detect a stabilizer jam when the pitch trim wheel is jammed. The flight control normal law remains active in this case and there is no ECAM warning.

– AP OFF

– MAN PITCH TRIM CHECK

The pitch trim wheel may not be fully jammed, the force needed may be higher than usual.

● **IF MAN TRIM AVAIL :**

– TRIM FOR NEUTRAL ELEV

If man pitch trim is available, trim to maintain the elevator at the zero position (indications on ECAM F/CTL page).

APPR PROC

● **IF MAN TRIM NOT AVAIL :**

– FOR LDG USE FLAP 3

Do not select configuration full, so as not to degrade handling qualities.

– GPWS LDG FLAP 3 ON

CAT 1 ONLY

FUEL LEAK

A fuel leak may be detected, if :

- . The sum of FOB and FU is significantly less than FOB at engine start, or is decreasing, or
- . A passenger observes fuel spray from engine/pylon or wing tip, or
- . The total fuel quantity decreases at an abnormal rate, or
- . A fuel imbalance develops, or
- . Fuel quantity of a tank decreases too fast (leak from engine/pylon, or hole in a tank), or
- . Fuel flow is excessive (leak from engine), or
- . Fuel is smelt in the cabin.

If visibility permits, leak source may be identified by a visual check from the cabin.

WHEN A LEAK IS CONFIRMED

LAND ASAP

■ LEAK FROM ENGINE/PYLON CONFIRMED :

Engine fuel leak can be confirmed by excessive fuel flow indication, or a visual check.

- THR LEVER (of affected engine) IDLE
- ENG MASTER (of affected engine) OFF
- FUEL X FEED USE AS RQRD

If the leak stops, the crossfeed valve can now be opened to re-balance fuel quantity, or to enable use of fuel from both wings. Do not restart the engine.

■ LEAK FROM ENGINE/PYLON NOT CONFIRMED or LEAK NOT LOCATED :

Stop any fuel transfer, and then monitor the depletion rate of each inner tank, to determine if the leak is from an engine or a wing (case 1), or from the Center tank or the APU feeding line (case 2).

- FUEL X FEED MAINTAIN CLOSED
- The crossfeed valve must remain closed to prevent the leak from affecting both sides.
- CTR TK PUMP 1+2 OFF

Each engine is fed via its associated inner tank only.

- INNER TANK FUEL QUANTITIES MONITOR
- Monitor the depletion rate of each inner tank.



STABILIZER JAM

The system may not detect a stabilizer jam when the pitch trim wheel is jammed. The flight control normal law remains active in this case and there is no ECAM warning.

– AP OFF

– MAN PITCH TRIM CHECK

The pitch trim wheel may not be fully jammed, the force needed may be higher than usual.

● **IF MAN TRIM AVAIL :**

– TRIM FOR NEUTRAL ELEV

If man pitch trim is available, trim to maintain the elevator at the zero position (indications on ECAM F/CTL page).

APPR PROC

● **IF MAN TRIM NOT AVAIL :**

– FOR LDG USE FLAP 3

Do not select configuration full, so as not to degrade handling qualities.

– GPWS LDG FLAP 3 ON

CAT 1 ONLY

FUEL LEAK

- R A fuel leak may be detected, if :
- R . The sum of FOB and FU is significantly less than FOB at engine start, or is decreasing, or
- R . A passenger observes a fuel spray from an engine/pylon or a wing tip, or
- R . The total fuel quantity decreases at an abnormal rate, or
- R . A fuel imbalance develops, or
- R . Fuel quantity of a tank decreases too fast (leak from engine/pylon, or hole in a tank), or
- R . Fuel Flow is excessive (leak from engine), or
- R . Fuel is smelt in the cabin, or
- R . The destination EFOB turns to amber on the F.PLN (or on the FUEL PRED) page, or
- R . "DEST EFOB BELOW MIN" appears on the MCDU scratchpad.
- R If visibility permits, leak source may be identified by a visual check from the cabin.

WHEN A LEAK IS CONFIRMED**LAND ASAP****■ LEAK FROM ENGINE/PYLON CONFIRMED:**

- R Engine fuel leak can be confirmed by excessive fuel flow indication, or a visual check.
- R – THR LEVER (of affected engine) IDLE
- R – ENG MASTER (of affected engine) OFF
- R – FUEL X FEED USE AS RQRD
- R If the leak stops, the crossfeed valve can now be opened to re-balance fuel quantity, or
- R to enable use of fuel from both wings. Do not restart the engine.

■ LEAK FROM ENGINE/PYLON NOT CONFIRMED or LEAK NOT LOCATED:

- R Stop any fuel transfer, and then monitor the depletion rate of each inner tank, to determine
- R if the leak is from an engine or a wing (Case 1), or from the Center tank, or the APU feeding
- R line (case 2).
- R – FUEL X FEED MAINTAIN CLOSED
- R The crossfeed valve must remain closed to prevent the leak from affecting both sides.
- R – CTR TK PUMP 1+2 OFF
- R Each engine is fed via its associated inner tank only.
- R – INNER TANK FUEL QUANTITIES MONITOR
- R Monitor the depletion rate of each inner tank.



STABILIZER JAM

The system may not detect a stabilizer jam when the pitch trim wheel is jammed. The flight control normal law remains active in this case and there is no ECAM warning.

– AP OFF

– MAN PITCH TRIM CHECK

The pitch trim wheel may not be fully jammed, the force needed may be higher than usual.

● **IF MAN TRIM AVAIL :**

– TRIM FOR NEUTRAL ELEV

If man pitch trim is available, trim to maintain the elevator at the zero position (indications on ECAM F/CTL page).

APPR PROC

● **IF MAN TRIM NOT AVAIL :**

– FOR LDG USE FLAP 3

Do not select configuration full, so as not to degrade handling qualities.

– GPWS LDG FLAP 3 ON

CAT 1 ONLY

FUEL LEAK

- R A fuel leak may be detected, if :
- R . The sum of FOB and FU is significantly less than FOB at engine start, or is decreasing, or
- R . A passenger observes fuel spray from engine/pylon or a wing tip, or
- R . The total fuel quantity is decreasing at an abnormal rate, or
- R . A fuel imbalance develops, or
- R . Fuel quantity of a tank decreases too fast (leak from engine/pylon, or hole in a tank), or
- R . A tank is overflowing (due to pipe rupture in a tank), or
- R . Fuel Flow is excessive (leak from engine), or
- R . Fuel is smelt in the cabin, or
- R . The destination EFOB turns to amber on the FPLN (or on the FUEL PRED) page, or
- R . "DEST EFOB BELOW MIN" appears on the MCDU scratchpad.
- R If visibility permits, leak source may be identified by a visual check from the cabin.

WHEN A LEAK IS CONFIRMED

LAND ASAP

- R ■ **LEAK FROM ENGINE/PYLON CONFIRMED:**
- R Engine fuel leak can be confirmed by excessive fuel flow indication, or a visual check.
- R – THR LEVER (of affected engine) IDLE
- R – ENG MASTER (of affected engine) OFF
- R – FUEL X FEED USE AS RQRD
- R If the leak stops, the crossfeed valve can now be opened to re-balance fuel quantity, or
- R to enable use of fuel from both wings. Do not restart the engine.
- R ■ **LEAK FROM ENGINE/PYLON NOT CONFIRMED or LEAK NOT**
- R **LOCATED:**
- R Stop any fuel transfer, and then monitor the depletion rate of each wing tank, to determine
- R if the leak is from an engine or a wing (case 1), or from the Center tank or the APU feeding
- R line (case 2).
- R – FUEL X FEED MAINTAIN CLOSED
- R The crossfeed valve must remain closed to prevent the leak from affecting both sides.
- R – CTR TK L+R XFR OFF
- R Each engine is fed via its associated wing tank only.
- R – WING TANK FUEL QUANTITIES MONITOR
- R Monitor the depletion rate of each wing tank.



FUEL LEAK (CONT'D)

■ **CASE 1 : IF ONE INNER TANK DEPLETES FASTER THAN THE OTHER BY AT LEAST 300 kg (660 lb) IN LESS THAN 30 MINUTES :**

An engine leak may still be suspected. Therefore :

- THR LEVER (engine on leaking side) IDLE
- ENG MASTER (engine on leaking side) OFF
- CTR TK PUMP 1+2 ON
- FUEL LEAK MONITOR

● **If leak stops :**

If the inner tank fuel quantity of the affected side stops decreasing, the engine leak is confirmed and stopped.

- FUEL X FEED USE AS RQRD
- The crossfeed valves can now be opened to re-balance fuel quantity, or to enable use of fuel from both wings. Do not restart the engine.*

● **If leak continues (after engine shutdown) :**

The inner tank fuel quantity of the affected side continues to decrease. If the leak has not stopped after engine shut down, a leak from the wing may be suspected.

- ENGINE RESTART CONSIDER

CAUTION

Do not open the FUEL X FEED valve, even if requested by another ECAM procedure.

Do not apply the FUEL IMBALANCE procedure. Approach and landing can be done, even with one full wing/one empty wing.

■ **CASE 2 : IF BOTH INNER TANKS DEplete AT A SIMILAR RATE :**

A leak from the Center tank or the APU feeding line may be suspected.

● **If fuel smell in the cabin :**

- APU (if ON) OFF
- This prevents additional fuel loss through the APU feeding line.*

● **When fuel quantity in one inner tank is less than 3 tons (6600 lb) :**

- CTR TK PUMP 1+2 ON

FUEL LEAK (CONT'D)

■ CASE 1 : IF ONE INNER TANK DEPLETES FASTER THAN THE OTHER BY AT LEAST 300 kg (660 lb) IN LESS THAN 30 MINUTES :

An engine leak may still be suspected. Therefore :

- THR LEVER (engine on leaking side) IDLE
- ENG MASTER (engine on leaking side) OFF
- CTR TK PUMP 1+2 ON
- FUEL LEAK MONITOR

● If leak stops :

If the inner tank fuel quantity of the affected side stops decreasing, the engine leak is confirmed and stopped.

- FUEL X FEED USE AS RQRD
- The crossfeed valves can now be opened to re-balance fuel quantity, or to enable use of fuel from both wings. Do not restart the engine.*

● If leak continues (after engine shutdown) :

The inner tank fuel quantity of the affected side continues to decrease. If the leak has not stopped after engine shut down, a leak from the wing may be suspected.

- ENGINE RESTART CONSIDER

CAUTION

Do not apply the FUEL IMBALANCE procedure. Approach and landing can be done, even with one full wing/one empty wing.

■ CASE 2 : IF BOTH INNER TANKS DEplete AT A SIMILAR RATE :

A leak from the Center tank or the APU feeding line may be suspected.

● If fuel smell in the cabin :

- APU (if ON) OFF
- This prevents additional fuel loss through the APU feeding line.*

● When fuel quantity in one inner tank is less than 3 tons (6600 lb) :

- CTR TK PUMP 1+2 ON

FUEL LEAK (CONT'D)

■ CASE 1 : IF ONE WING TANK DEPLETES FASTER THAN THE OTHER BY AT LEAST 300 kg (660 lb) IN LESS THAN 30 MINUTES :

An engine leak may still be suspected. Therefore :

- THR LEVER (engine on leaking side) IDLE
- ENG MASTER (engine on leaking side) OFF
- FUEL LEAK MONITOR

● If leak stops :

If the wing tank fuel quantity of the affected side stops decreasing, the engine leak is confirmed and stopped.

- CTR TK L+R XFR ON
- FUEL X FEED USE AS RQRD

The crossfeed valves can now be opened to re-balance fuel quantity, or to enable use of fuel from both wings. Do not restart the engine.

● If leak continues (after engine shutdown) :

The wing tank fuel quantity of the affected side continues to decrease. If the leak has not stopped after engine shut down, a leak from the wing may be suspected.

- ENGINE RESTART CONSIDER
- CTR TK XFR (non-leaking side) ON

CAUTION

Do not apply the FUEL IMBALANCE procedure. Approach and landing can be done, even with one full wing/one empty wing.

■ CASE 2 : IF BOTH WING TANKS DEplete AT A SIMILAR RATE :

A leak from the Center tank or the APU feeding line may be suspected.

● If fuel smell in the cabin :

- APU (if ON) OFF
- This prevents additional fuel loss through the APU feeding line.*

● When fuel quantity in one wing tank is less than 3 tons (6600 lb) :

- CTR TK L+R XFR ON

GRVTY FUEL FEEDING

- ENG MODE SEL IGN
- AVOID NEGATIVE G FACTOR

● **DETERMINE GRAVITY FEED CEILING :**

Consult the following table to determine the flight altitude limitation.

R
R

Flight conditions at the time of gravity feeding	Gravity feed ceiling
Flight time above FL300 more than 30 minutes (Fuel deaerated)	Current FL*
Flight time above FL300 less than 30 minutes (Fuel non deaerated)	FL 300*
Aircraft flight level never exceeded FL300 (Fuel non deaerated)	FL150* or 7000 ft above takeoff airport, whichever is higher

* For JET B, gravity feed ceiling is FL100 in all cases.
DESCEND TO GRVTY FEED CEILING (if applicable).

● **WHEN REACHING GRVTY FEED CEILING :**

- FUEL X FEED OFF

● **IF NO FUEL LEAK AND FOR AIRCRAFT HANDLING :**

If no fuel leak and for flight with only one engine running (this engine being fed by gravity), apply the following :

- FUEL X FEED ON
- BANK ANGLE . . . 1 DEG WING DOWN ON LIVE ENGINE SIDE
- RUDDER TRIM USE

● **WHEN FUEL IMBALANCE REACHES 1 000 kg (2200 lbs) :**

- BANK ANGLE 2 or 3 DEG WING DOWN
ON LIVE ENG SIDE

FUEL IMBALANCE

- FOB CHECK
Compare the FOB+FU with the FOB at departure. If the difference is significant, or if the FOB+FU decreases, suspect a fuel leak.

CAUTION

A fuel imbalance may indicate a fuel leak.

Do not apply this procedure, if a fuel leak is suspected. Refer to the FUEL LEAK procedure.

- FUEL X FEED ON

● **On the lighter side and in the center tank :**

- FUEL PUMPS OFF

● **When fuel is balanced :**

- FUEL PUMPS (WING + CTR) ON
- FUEL X FEED OFF

GRVTY FUEL FEEDING

- ENG MODE SEL IGN
- AVOID NEGATIVE G FACTOR

● **DETERMINE GRAVITY FEED CEILING :**

Consult the following table to determine the flight altitude limitation.

Flight conditions at the time of gravity feeding	Gravity feed ceiling
Flight time above FL300 more than 30 minutes (Fuel deaerated)	Current FL*
Flight time above FL300 less than 30 minutes (Fuel non deaerated)	FL 300*
Aircraft flight level never exceeded FL300 (Fuel non deaerated)	FL150* or 7000 ft above takeoff airport, whichever is higher

* For JET B, gravity feed ceiling is FL100 in all cases.
DESCEND TO GRVTY FEED CEILING (if applicable).

● **WHEN REACHING GRVTY FEED CEILING :**

- FUEL X FEED OFF

● **IF NO FUEL LEAK AND FOR AIRCRAFT HANDLING :**

If no fuel leak and for flight with only one engine running (this engine being fed by gravity), apply the following :

- FUEL X FEED ON
- BANK ANGLE . . . 1 DEG WING DOWN ON LIVE ENGINE SIDE
- RUDDER TRIM USE

● **WHEN FUEL IMBALANCE REACHES 1 000 kg (2200 lbs) :**

- BANK ANGLE 2 or 3 DEG WING DOWN
ON LIVE ENG SIDE

FUEL IMBALANCE

- FOB CHECK
- Compare the FOB+FU with the FOB at departure. If the difference is significant, or if the FOB+FU decreases, suspect a fuel leak.*

CAUTION

A fuel imbalance may indicate a fuel leak.

Do not apply this procedure, if a fuel leak is suspected. Refer to the FUEL LEAK procedure.

- FUEL X FEED ON
- CTR TK L+R XFR OFF
- **On the lighter side :**
 - FUEL PUMPS OFF
- **When fuel is balanced :**
 - FUEL PUMPS ON
 - CTR TK L+R XFR ON
 - FUEL X FEED OFF

ACT XFR FAULT PROC

In ELEC EMER CONFIG this caution is incorrectly triggered. Disregard this procedure.

- ALL ACT pushbutton CHECK NOT ISOL
 - ACT XFR selector APPROPRIATE ACT
- Select the highest numbered ACT which has not transferred.*
- ACT XFR MODE SEL pushbutton MAN

● If FUEL ACT SYSTEM FAULT

- PROC APPLY

● If no FUEL ACT SYSTEM FAULT and ACT does not transfer :

- ACT XFR selector OFF
 - ACT XFR MODE SEL pb CONFIRM MAN
- Use only wing and center tank fuel so as to keep the center of gravity within limits.*

■ If 2 ACTs fitted and ZFCG is in area A (see page 2.09.C) :

- CTR TK PUMPS OFF
- Refer to ZFCG graphs on page 2.09C.*

■ If 3 or 4 ACTs fitted and ZFCG is in area B (see page 2.09.C) :

- CTR TK PUMPS OFF

■ If 5 or 6 ACTs fitted and ZFCG is in area C (see page 2.09.C) :

- CTR TK PUMPS OFF
- Use only wing tank fuel so as to keep the center of gravity within limits*

ACT SYSTEM FAULT PROC

This procedure ensures that the aircraft center of gravity does not go outside normal limits.

■ If ACT 6 is not empty :

- ACT XFR selector OFF
 - ACT XFR MODE SEL pb CONFIRM MAN
- Use only wing and center tank fuel so as to keep the center of gravity within limits.*

● If ZFCG is in area C :

- CTR TK PUMPS OFF
- Refer to ZFCG graphs on page 2.09C.*
Use only wing tank fuel so as to keep the center of gravity within limits.

■ If ACT 6 is empty or not installed :

- ACT XFR MODE SEL pushbutton AUTO
- Auto system will skip the failed ACT and will transfer the next ACT.*
- ACT TRANSFER MONITOR
- ACT XFR FAULT warning and ACT transfer arrow are now inhibited, so the system must be closely monitored.*

● If the next ACT does not transfer :

- ACT XFR selector OFF
- ACT XFR MODE SEL pb MAN

■ If 2 ACTs fitted and ZFCG is in area A (see page 2.09.C) :

- CTR TK PUMPS OFF
- Refer to ZFCG graphs on page 2.09C.*

■ If 3 or 4 ACTs fitted and ZFCG is in area B (see page 2.09.C) :

- CTR TK PUMPS OFF

■ If 5 or 6 ACTs fitted and ZFCG is in area C (see page 2.09.C) :

- CTR TK PUMPS OFF
- Use only wing tank fuel so as to keep the center of gravity within limits.*

ACT UNUSABLE PROC

■ If only ACT 1 unusable. (ACT 2 empty.)

- ACT AUTO
This stops the pump dry running.

■ If only ACT 2 unusable. (ACT 1 empty.)

- ACT AUTO
This stops the pump dry running.

● If ZFCG is not known, or if ZFCG is aft of 36.5 %

- CTR TK XFR OFF
*This ensures that at least 2 tonnes of fuel will remain in the center tank. Keeping this fuel in the center tank helps to keep the center of gravity forward.
CTR TK XFR OFF caution will be displayed. Disregard ECAM procedure.
FUEL AUTO TRANSFER FAULT caution will be displayed when a wing tank quantity reaches 5000 kg. Disregard ECAM procedure.*

■ If both ACT unusable.

- ACT AUTO
This stops the pump dry running.

● If ZFCG is between 30 and 32.5 %

- CTR TK XFR OFF
*This ensures that at least 2 tonnes of fuel will remain in the center tank. Keeping this fuel in the center tank helps to keep the center of gravity forward.
CTR TK XFR OFF caution will be displayed. Disregard ECAM procedure.
FUEL AUTO TRANSFER FAULT caution will be displayed when a wing tank quantity reaches 5000 kg. Disregard ECAM procedure.*

● If ZFCG is not known, or if ZFCG is aft of 32.5 %

- CTR TK XFR OFF
*This ensures that at least 2 tonnes of fuel will remain in the center tank. Keeping this fuel in the center tank helps to keep the center of gravity forward.
CTR TK XFR OFF caution will be displayed. Disregard ECAM procedure.
FUEL AUTO TRANSFER FAULT caution will be displayed when a wing tank quantity reaches 5000 kg. Disregard ECAM procedure.*
- MAXIMUM FLIGHT TIME 2.5 HOURS
Ensures aft CG limits are not exceeded..

FWD ACT ISOLATED PROC

In ELEC EMER CONFIG this caution is incorrectly triggered. Disregard this procedure.

■ **If no ENG FAIL warning :**

- FWD ACT pushbutton OVRD
FWD ACT (4 and 6) were isolated due to spurious damage detection.

■ **If ENG FAIL warning and ACT 6 is not empty :**

- ACT XFR selector OFF
- ACT XFR MODE SEL pushbutton CONFIRM MAN
Use only wing and center tank fuel so as to keep the center of gravity within limits.

● **If ZFCG is in area C :**

- CTR TK PUMPS OFF
*Refer to ZFCG graphs on page 2.09C.
Use only wing tank fuel so as to keep the center of gravity within limits.*

■ **If ENG FAIL warning and ACT 6 is empty :**

- CONTROL ACT SEQUENCE MANUALLY.
Select each ACT in turn when its fuel is required, except ACT 4. ACT 4 will not transfer as it is isolated.

ZFCG GRAPHS

To be used in case of ACT XFR FAULT, ACT SYSTEM FAULT and FWD ACT isolated procedures.

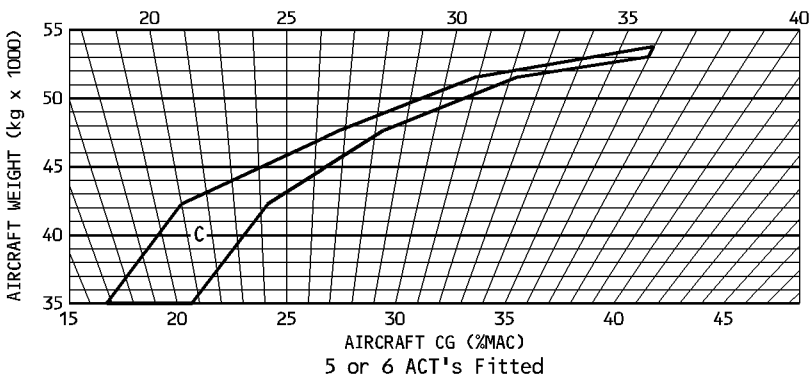
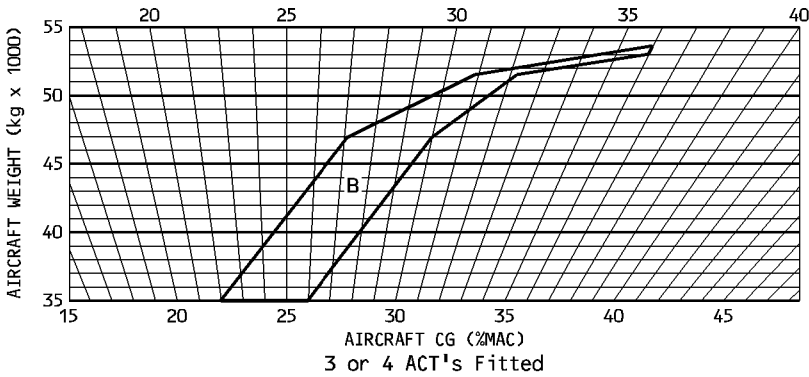
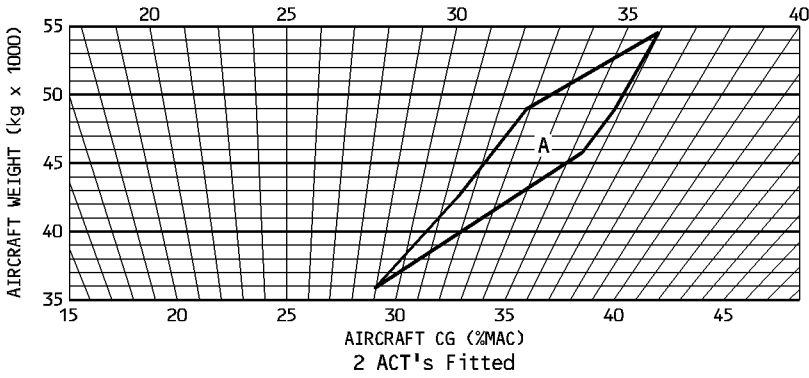

NCL5-00-0002-009C-A100AA

DOUBLE PROBE HEAT FAILURE● **If icing conditions cannot be avoided :**

- One of affected ADRs OFF
- F/CTL ADR DISAGREE

DISPLAY UNIT FAILURE■ **AFFECTED DU IS BLANK or DISPLAY IS DISTORTED :**

- DU (affected) AS RQRD
The DU can be switched off.
- ECAM/ND XFR (if ECAM DUs affected) USE
Transfer SD to the F/O or CAPT ND.
- PFD/ND XFR (if EFIS DUs affected) USE

■ **DIAGONAL LINE ON THE AFFECTED DU :**

- EIS DMC SWITCHING AS RQRD

● **IF UNSUCCESSFUL :**

- DU (affected) OFF THEN ON

NOTE : ND display may disappear, in case too many waypoints and associated information are displayed. Reduce the range, or deselect WPT or CSTR, and the display will automatically recover after about 30 seconds.

■ **INVERSION OF EWD AND SD :**

- ECAM UPPER DISPLAY OFF THEN ON
The action on the EIS DMC SWITCHING selector produces the same effect.

R

DOUBLE AOA HEAT FAILURE

- **If icing conditions cannot be avoided :**
 - One of affected ADRs OFF
 - NAV ADR DISAGREE

R

DISPLAY UNIT FAILURE

R

R

R

R

R

R

R

R

- **DU is blank, or display is distorted :**
 - DU (affected) AS RQRD
The DU can be switched off.
 - ECAM/ND XFR (if ECAM DUs affected) USE
Transfer SD to the F/O or CAPT ND.
 - PFD/ND XFR (if EFIS DUs affected) USE
- **INVALID DISPLAY UNIT message is displayed :**
This may be caused by a DU failure.
 - FOR AUTOMATIC DU RECOVERY . . . WAIT MORE THAN 40s
- **IF DU IS AUTOMATICALLY RECOVERED :**
No crew action is required.
- **IF DU IS NOT RECOVERED :**
 - Non-recovered DU AS RQRD
The DU can be switched off.
- **INVALID DATA message is displayed (not on all DUs) :**
 - EIS DMC SWITCHING AS RQRD
- **IF UNSUCCESSFUL :**
 - DU (affected) OFF THEN ON

NOTE : ND display may disappear, in case too many waypoints and associated information are displayed. Reduce the range, or deselect WPT or CSTR, and the display will automatically recover after about 30 seconds.
- **INVALID DATA is displayed on all DUs :**
The autopilot, autothrust and MCDU navigation data, remain available.
 - FOR AUTOMATIC DUs RECOVERY . . . WAIT MORE THAN 40s
- **IF ALL DUs ARE AUTOMATICALLY RECOVERED :**
No crew action is required.
- **IF ONE OR MORE DUs ARE NOT RECOVERED :**
 - Non-recovered DUs OFF FOR 40s.
 - Non-recovered DUs BACK ON sequentially
- **If the initial failure re-occurs (the INVALID DATA message appears on all DUs) when switching a given DU back ON :**
Apply the entire procedure again from the beginning. Leave this specific DU permanently OFF.
- **Inversion of EWD and SD :**
 - ECAM UPPER DISPLAY OFF THEN ON
The action on the EIS DMC SWITCHING selector produces the same effect.

ECAM SINGLE DISPLAY

Only the EWD is available. No SD on the other DUs.

■ To call a SYS page :

- PRESS AND MAINTAIN the SYS page key on the ECP

■ OVERFLOW ON THE STATUS page :

- PRESS AND MAINTAIN the STS key on the ECP
The first page of the STATUS is displayed.
- RELEASE IT, THEN PRESS IT AGAIN WITHIN 2 SECONDS
The second page of the STATUS is displayed.
- CONTINUE UNTIL THE OVERFLOW ARROW DISAPPEARS
When the STS key is released for more than 2 seconds, the EWD is displayed again.

RESIDUAL BRAKING PROC**■ IN FLIGHT :**

- BRAKE PEDALS APPLY SEVERAL TIMES

Press the brakes pedals several times. This could zero a residual pressure on the alternate system.

● IF RESIDUAL PRESSURE REMAINS :

- A/SKID & N/W STRG selector KEEP ON

■ IF AUTOBRAKE IS AVAILABLE :

- FOR LANDING AUTO/BRK MED

Using MED mode gives immediate priority to normal braking upon landing gear touchdown, which cancels alternate pressure.

■ IF AUTOBRAKE IS NOT AVAILABLE :

- JUST AFTER TOUCHDOWN APPLY BRAKING

Pressing the brake pedals gives immediate priority to normal braking, which cancels residual alternate pressure.

- Beware of possible braking asymmetry after touchdown, which can be controlled by using the pedals.

NOTE : *In case of taxi with deflated or damaged tires, refer to the TAXI WITH DEFLATED TIRES procedure (FCOM 3.01.32, page 2).*

L/G GRAVITY EXTENSION

- GRAVITY GEAR EXTN handcrank PULL AND TURN
Rotate the handle clockwise 3 turns until reaching the mechanical stop, even if resistance is felt.
- L/G lever DOWN
- GEAR DOWN indications (if available) CHECK

NOTE : 1. Depending on aircraft speed, the display may show the landing gear doors in the amber transit position.

2. In the event of gravity extension caused by the failure of both LGCIUs, landing gear position indications on the ECAM are lost. LDG GEAR lights on the LDG control panel remain available, if LGCIU1 is electrically-supplied.

3. The LGCIU 2 FAULT or BRAKES BSCU CH 1(2) FAULT warning may be spuriously triggered after a gravity extension.

4. If the three green downlock arrows are not on, it is possible that the handcrank is not at the mechanical stop. Check that the handcrank is firmly against the mechanical stop.

CAUTION

Nosewheel steering is lost.

■ If successful :

Do not reset the free-fall system : This will avoid such undesirable effects as further loss of fluid, in the event of a leak, or possible landing gear unlocking, in the event of a gear selector valve jamming in the UP position.

NOTE : The free-fall system may be reset in flights used for training. If the green hydraulic system is available, resetting the free-fall system allows the landing gear doors to be closed and the nosewheel steering to operate.

The flight crew should not reset the free-fall system on the ground after flight.

■ If unsuccessful :

- LDG WITH ABNORMAL L/G procedure APPLY

R

LDG WITH ABNORMAL L/G

PREPARATION

- CABIN CREW NOTIFY
 - ATC NOTIFY
 - GALLEY OFF
- . Consider fuel reduction to a safe minimum.

● **If NOSE L/G abnormal :**

- CG location (if possible) AFT
- . 10 PAX from front to rear moves the CG roughly 4 % aft.
 . 10 PAX from mid to rear moves the CG roughly 2.5 % aft.

● **If one MAIN L/G abnormal :**

- FUEL IMBALANCE CONSIDER
- . Open the fuel X-FEED valve and switch off the pumps on the side with landing gear normally extended.
- OXYGEN CREW SUPPLY OFF
 - SIGNS ON
 - CABIN and COCKPIT PREPARE
- . Loose equipment secured
 . Survival equipment prepared
 . Belts and shoulder harness locked.

APPROACH

- GPWS SYS OFF
 - L/G LEVER CHECK DOWN
 - GRVTY GEAR EXTN handcrank TURN BACK TO NORMAL
 - AUTOBRAKE DO NOT ARM
 - EMER EXIT LT ON
 - CABIN REPORT OBTAIN
- **If one or both MAIN L/G abnormal :**
- A/SKID & NW STRG OFF
 - MAX BRAKE PR 1000 PSI
 - GROUND SPOILERS DO NOT ARM

BEFORE LANDING

- RAM AIR ON
- BRACE FOR IMPACT ORDER



Cont'd

L/G GRAVITY EXTENSION

- GRAVITY GEAR EXTN handcrank PULL AND TURN
Rotate the handle clockwise 3 turns until reaching the mechanical stop, even if resistance is felt.
- L/G lever DOWN
- GEAR DOWN indications (if available) CHECK

NOTE : 1. Depending on aircraft speed, the display may show the landing gear doors in the amber transit position.

2. In the event of gravity extension caused by the failure of both LGCIUs, landing gear position indications on the ECAM are lost. LDG GEAR lights on the LDG control panel remain available, if LGCIU1 is electrically-supplied.

3. The LGCIU 2 FAULT or BRAKES SYS 1(2) FAULT warning may be spuriously triggered after a gravity extension.

4. If the three green downlock arrows are not on, it is possible that the handcrank is not at the mechanical stop. Check that the handcrank is firmly against the mechanical stop.

CAUTION

Nosewheel steering is lost.

■ If successful :

Do not reset the free-fall system : This will avoid such undesirable effects as further loss of fluid, in the event of a leak, or possible landing gear unlocking, in the event of a gear selector valve jamming in the UP position.

NOTE : The free-fall system may be reset in flights used for training. If the green hydraulic system is available, resetting the free-fall system allows the landing gear doors to be closed and the nosewheel steering to operate.

The flight crew should not reset the free-fall system on the ground after flight.

■ If unsuccessful :

- LDG WITH ABNORMAL L/G procedure APPLY

R

LDG WITH ABNORMAL L/G**PREPARATION**

- CABIN CREW NOTIFY
 - ATC NOTIFY
 - GALLEY OFF
- . Consider fuel reduction to a safe minimum.

● **If NOSE L/G abnormal :**

- CG location (if possible) AFT
- . 10 PAX from front to rear moves the CG roughly 4 % aft.
 . 10 PAX from mid to rear moves the CG roughly 2.5 % aft.

● **If one MAIN L/G abnormal :**

- FUEL IMBALANCE CONSIDER
- . Open the fuel X-FEED valve and switch off the pumps on the side with landing gear normally extended.
- OXYGEN CREW SUPPLY OFF
 - SIGNS ON
 - CABIN and COCKPIT PREPARE
- . Loose equipment secured
 . Survival equipment prepared
 . Belts and shoulder harness locked.

APPROACH

- GPWS SYS OFF
 - L/G LEVER CHECK DOWN
 - GRVTY GEAR EXTN handcrank TURN BACK TO NORMAL
 - AUTOBRAKE DO NOT ARM
 - EMER EXIT LT ON
 - CABIN REPORT OBTAIN
- **If one or both MAIN L/G abnormal :**
- A/SKID & NW STRG OFF
 - MAX BRAKE PR 1000 PSI
 - GROUND SPOILERS DO NOT ARM

BEFORE LANDING

- RAM AIR ON
- BRACE FOR IMPACT ORDER



Cont'd

L/G GRAVITY EXTENSION

- GRAVITY GEAR EXTN handcrank PULL AND TURN
Rotate the handle clockwise 3 turns until reaching the mechanical stop, even if resistance is felt.
- L/G lever DOWN
- GEAR DOWN indications (if available) CHECK

NOTE : 1. Depending on aircraft speed, the display may show the landing gear doors in the amber transit position.
 2. In the event of gravity extension caused by the failure of both LGCIUs, landing gear position indications on the ECAM are lost. LDG GEAR lights on the LDG control panel remain available, if LGCIU1 is electrically-supplied.
 3. The LGCIU 2 FAULT or BRAKES SYS 1(2) FAULT warning may be spuriously triggered after a gravity extension.
 4. If the three green downlock arrows are not on, it is possible that the handcrank is not at the mechanical stop. Check that the handcrank is firmly against the mechanical stop.

■ If successful :

Do not reset the free-fall system : This will avoid such undesirable effects as further loss of fluid, in the event of a leak, or possible landing gear unlocking, in the event of a gear selector valve jamming in the UP position.

NOTE : The free-fall system may be reset in flights used for training. If the green hydraulic system is available, resetting the free-fall system allows the landing gear doors to be closed.
 The flight crew should not reset the free-fall system on the ground after flight.

■ If unsuccessful :

- LDG WITH ABNORMAL L/G procedure APPLY

ASYMMETRIC BRAKING

Normal braking is faulty, or the green hydraulic system is in low pressure, and all brakes of one gear are released.

- Apply brake progressively on the available side. Counter swing with the rudder.
- Avoid crosswind in excess of 10 knots from the side of the available brake.

● If only one reverse is available :

- Do not use Reverse on the side of the available brake.
- LDG DIST PROC APPLY

● In case of NORM BRK FAULT, multiply the landing distance by :

- 2.35 on dry runway,
- 1.85 on wet runway,
- 1.90 on contaminated runway

● In case of G SYS LO PR, multiply the landing distance by :

- 2.50 on dry runway,
- 2.25 on wet runway,
- 2.75 on contaminated runway.

R
R
R
R
R
R
R
R

LDG WITH ABNORMAL L/G

PREPARATION

- CABIN CREW NOTIFY
 - ATC NOTIFY
 - GALLEY OFF
- . Consider fuel reduction to a safe minimum.

● **If NOSE L/G abnormal :**

- CG location (if possible) AFT
- . 10 PAX from front to rear moves the CG roughly 4 % aft.
 . 10 PAX from mid to rear moves the CG roughly 2.5 % aft.

● **If one MAIN L/G abnormal :**

- FUEL IMBALANCE CONSIDER
- . Open the fuel X-FEED valve and switch off the pumps on the side with landing gear normally extended.
- OXYGEN CREW SUPPLY OFF
 - SIGNS ON
 - CABIN and COCKPIT PREPARE
- . Loose equipment secured
 . Survival equipment prepared
 . Belts and shoulder harness locked.

APPROACH

- GPWS SYS OFF
 - L/G LEVER CHECK DOWN
 - GRVTY GEAR EXTN handcrank TURN BACK TO NORMAL
 - AUTOBRAKE DO NOT ARM
 - EMER EXIT LT ON
 - CABIN REPORT OBTAIN
- **If one or both MAIN L/G abnormal :**
- A/SKID & NW STRG OFF
 - MAX BRAKE PR 1000 PSI
 - GROUND SPOILERS DO NOT ARM

BEFORE LANDING

- RAM AIR ON
- BRACE FOR IMPACT ORDER



Cont'd

LDG WITH ABNORMAL L/G (cont'd)**FLARE, TOUCHDOWN AND ROLL OUT**

Engines should be shut down sufficiently early to ensure fuel is shut off before the nacelles impact, but sufficiently late to ensure adequate hydraulic supplies for the flight controls.

Engine pumps continue to supply adequate hydraulic pressure for 30 seconds after first engine shutdown.

– REVERSE DO NOT USE

● **If NOSE L/G abnormal**

– NOSE MAINTAIN UP

After touchdown, keep the nose off the runway by use of the elevator.

Then, lower the nose onto the runway before elevator control is lost.

– BRAKES (compatible with elevator efficiency) APPLY

– ENG MASTERS OFF

Shutdown the engines before nose impact.

● **If one MAIN L/G abnormal**

– ENG MASTERS OFF

At touchdown, shut down both engines.

– FAILURE SIDE WING MAINTAIN UP

Use roll control, as necessary, to maintain the unsupported wing up as long as possible.

– DIRECTIONAL CONTROL MAINTAIN

Use rudder and brakes (maximum 1000 psi) to maintain the runway axis as long as possible.

● **If both MAIN L/G abnormal**

– ENG MASTERS OFF

Shut down the engines in the flare, before touchdown.

– PITCH ATTITUDE (at touchdown) NOT LESS THAN 6°

WHEN A/C STOPPED

– ENG (all) and APU FIRE pushbutton PUSH

Pressing the ENG FIRE pb shuts off the related hydraulic pressure within a short time.

– ENG (all) and APU AGENT DISCH

– EVACUATION INITIATE

Announce : "PASSENGER EVACUATION" via the P.A. system, and press the EVAC COMMAND pushbutton.

All emergency and passenger doors may be used to evacuate the aircraft.

R

F/CTL ADR DISAGREE

If one ADR is faulty, or has been rejected by the ELAC, and if there is a speed or alpha disagreement between the 2 remaining ADRs, alternate law becomes active and protections are lost.

– AIR SPD X CHECK

■ **IF SPD DISAGREE :**

Refer to the ADR CHECK PROC paper procedure to determine the faulty ADR.

– FAULTY ADR OFF

■ **IF NO SPD DISAGREE :**

– AOA DISCREPANCY

F/CTL ALTN LAW

(PROT LOST)

– MAX SPEED 320 KT

R

LDG WITH ABNORMAL L/G (cont'd)**FLARE, TOUCHDOWN AND ROLL OUT**

Engines should be shut down sufficiently early to ensure fuel is shut off before the nacelles impact, but sufficiently late to ensure adequate hydraulic supplies for the flight controls.

Engine pumps continue to supply adequate hydraulic pressure for 30 seconds after first engine shutdown.

– REVERSE DO NOT USE

● **If NOSE L/G abnormal**

– NOSE MAINTAIN UP

After touchdown, keep the nose off the runway by use of the elevator.

Then, lower the nose onto the runway before elevator control is lost.

– BRAKES (compatible with elevator efficiency) APPLY

– ENG MASTERS OFF

Shutdown the engines before nose impact.

● **If one MAIN L/G abnormal**

– ENG MASTERS OFF

At touchdown, shut down both engines.

– FAILURE SIDE WING MAINTAIN UP

Use roll control, as necessary, to maintain the unsupported wing up as long as possible.

– DIRECTIONAL CONTROL MAINTAIN

Use rudder and brakes (maximum 1000 psi) to maintain the runway axis as long as possible.

● **If both MAIN L/G abnormal**

– ENG MASTERS OFF

Shut down the engines in the flare, before touchdown.

– PITCH ATTITUDE (at touchdown) NOT LESS THAN 6°

WHEN A/C STOPPED

– ENG (all) and APU FIRE pushbutton PUSH

Pressing the ENG FIRE pb shuts off the related hydraulic pressure within a short time.

– ENG (all) and APU AGENT DISCH

– EVACUATION INITIATE

Announce : "PASSENGER EVACUATION" via the P.A. system, and press the EVAC COMMAND pushbutton.

All emergency and passenger doors may be used to evacuate the aircraft.

R

NAV ADR DISAGREE

If one ADR is faulty, or has been rejected by the ELAC, and if there is a speed or alpha disagreement between the 2 remaining ADRs, alternate law becomes active, and protections are lost.

– AIR SPD X CHECK

■ **IF SPD DISAGREE :**

– ADR CHECK PROC APPLY

Refer to the ADR CHECK PROC paper procedure to determine the faulty ADR.

■ **IF NO SPD DISAGREE :**

– AOA DISCREPANCY

F/CTL ALTN LAW

(PROT LOST)

– MAX SPEED 320 KT

R

UNRELIABLE SPEED INDICATION/ADR CHECK PROC

● If the safe conduct of the flight is impacted :

MEMORY ITEMS

- AP/FD OFF
- A/THR OFF
- PITCH/THRUST :
 - Below THRUST RED ALT 15°/TOGA
 - Above THRUST RED ALT and Below FL 100 10°/CLB
 - Above THRUST RED ALT and Above FL 100 5°/CLB
- FLAPS Maintain current CONFIG
- SPEEDBRAKES Check retracted
- L/G UP

● When at, or above MSA or Circuit Altitude :

- Level off for troubleshooting

- GPS ALTITUDE Display on MCDU

● To level off for troubleshooting :

NOTE : Check the actual slat/flap configuration on ECAM, since flap auto-retraction may occur.

PITCH / THRUST FOR INITIAL LEVEL OFF

SLATS / FLAPS EXTENDED				
		Above 81 t	81 t – 68 t	Below 68 t
CONF	Speed	Pitch (°) / Thrust (% N1)		
3	F	4.0 / 70.7	4.0 / 66.4	4.0 / 61.5
2	F	7.0 / 68.9	7.0 / 64.6	7.0 / 59.9
1+F	S	3.5 / 67.6	3.0 / 63.8	3.0 / 58.6
1	S	7.5 / 65.5	7.5 / 61.4	7.5 / 56.5
CLEAN				
FL	Speed	Pitch (°) / Thrust (% N1)		
Below FL 200	270 kts	3.5 / 69.0	2.5 / 66.1	1.5 / 63.7
FL 200 – FL 280	300 kts	2.0 / 73.9	1.5 / 75.9	1.0 / 73.9
Above FL 280	M 0.76	2.5 / 83.7	2.5 / 81.6	2.0 / 79.0

Flying technique to stabilize speed :

- Adjust pitch in order to fly the required flight path.
- When target pitch is reached, flying intended flight path, adjust thrust to target.
 - If the aircraft pitch tends to increase, aircraft is slow, then increase thrust ;
 - If the aircraft pitch tends to decrease, aircraft is fast, then decrease thrust.



R UNRELIABLE SPEED INDICATION/ADR CHECK PROC (CONT'D)

WHEN FLIGHT PATH IS STABILIZED

– PROBE/WINDOW HEAT ON

Technical recommendations :

- Respect Stall Warning
- To monitor speed, refer to IRS Ground Speed, or GPS Ground Speed variations

● **If remaining altitude indication is unreliable :**

- Do not use FPV and/or V/S, which are affected.
- ATC altitude is affected. Notify the ATC.
- Refer to GPS altitude : altitude variations may be used to control level flight, and is an altitude cue.
- Refer to Radio Altimeter.

CAUTION

If the failure is due to radome destruction, the drag will increase and therefore N1 must be increased by 5%. Fuel flow will increase by about 27%.



UNRELIABLE SPEED INDICATION/ADR CHECK PROC

● If the safe conduct of the flight is impacted :

MEMORY ITEMS

- AP/FD OFF
- A/THR OFF
- PITCH/THRUST :
 - Below THRUST RED ALT 15°/TOGA
 - Above THRUST RED ALT and Below FL 100 10°/CLB
 - Above THRUST RED ALT and Above FL 100 5°/CLB
- FLAPS Maintain current CONFIG
- SPEEDBRAKES Check retracted
- L/G UP

● When at, or above MSA or Circuit Altitude :

- Level off for troubleshooting

- GPS ALTITUDE Display on MCDU

● To level off for troubleshooting :

NOTE : Check the actual slat/flap configuration on ECAM, since flap auto-retraction may occur.

PITCH / THRUST FOR INITIAL LEVEL OFF

SLATS / FLAPS EXTENDED				
		Above 66 t	66 t – 56 t	Below 56 t
CONF	Speed	Pitch (°) / Thrust (% N1)		
3	F	7.0 / 62.0	7.0 / 57.9	7.0 / 53.3
2	F	8.5 / 61.3	8.5 / 57.1	8.5 / 52.7
1+F	S	3.5 / 62.6	3.5 / 58.5	3.5 / 54.2
1	S	7.5 / 59.1	7.5 / 55.5	7.5 / 51.1
CLEAN				
FL	Speed	Pitch (°) / Thrust (% N1)		
Below FL 200	250 kts	3.5 / 62.4	3.0 / 60.3	2.0 / 58.8
FL 200 – FL 320	275 kts	2.5 / 74.3	2.0 / 72.7	1.5 / 71.4
Above FL 320	M 0.76	3.0 / 80.1	2.5 / 78.6	2.0 / 76.3

Flying technique to stabilize speed :

- Adjust pitch in order to fly the required flight path.
- When target pitch is reached, flying intended flight path, adjust thrust to target.
 - If the aircraft pitch tends to increase, aircraft is slow, then increase thrust ;
 - If the aircraft pitch tends to decrease, aircraft is fast, then decrease thrust.



R UNRELIABLE SPEED INDICATION/ADR CHECK PROC (CONT'D)

WHEN FLIGHT PATH IS STABILIZED

– PROBE/WINDOW HEAT ON

Technical recommendations :

- Respect Stall Warning
- To monitor speed, refer to IRS Ground Speed, or GPS Ground Speed variations

● **If remaining altitude indication is unreliable :**

- Do not use FPV and/or V/S, which are affected.
- ATC altitude is affected. Notify the ATC.
- Refer to GPS altitude : altitude variations may be used to control level flight, and is an altitude cue.
- Refer to Radio Altimeter.

CAUTION

If the failure is due to radome destruction, the drag will increase and therefore N1 must be increased by 5%. Fuel flow will increase by about 27%.



UNRELIABLE SPEED INDICATION/ADR CHECK PROC

- If the safe conduct of the flight is impacted :

MEMORY ITEMS

- AP/FD OFF
- A/THR OFF
- PITCH/THRUST :
 - Below THRUST RED ALT 15°/TOGA
 - Above THRUST RED ALT and Below FL 100 10°/CLB
 - Above THRUST RED ALT and Above FL 100 5°/CLB
- FLAPS Maintain current CONFIG
- SPEEDBRAKES Check retracted
- L/G UP

- When at, or above MSA or Circuit Altitude :

- Level off for troubleshooting

- GPS ALTITUDE Display on MCDU

- To level off for troubleshooting :

NOTE : Check the actual slat/flap configuration on ECAM, since flap auto-retraction may occur.

PITCH / THRUST FOR INITIAL LEVEL OFF

		SLATS / FLAPS EXTENDED		
		Above 67 t	67 t – 57 t	Below 57 t
CONF	Speed	Pitch (°) / Thrust (% N1)		
3	F	7.5 / 61.8	7.5 / 57.5	7.5 / 53.0
2	F	9.0 / 61.6	9.0 / 57.3	9.0 / 52.8
1+F	S	4.5 / 60.2	4.5 / 56.1	4.5 / 51.2
1	S	7.5 / 58.0	7.5 / 53.9	7.5 / 48.9
		CLEAN		
FL	Speed	Pitch (°) / Thrust (% N1)		
Below FL 200	250 kts	4.0 / 62.4	3.0 / 60.1	2.0 / 58.3
FL 200 – FL 320	275 kts	3.0 / 73.4	2.0 / 71.6	1.5 / 70.2
Above FL 320	M 0.76	2.5 / 79.2	2.5 / 78.1	2.0 / 77.0

- **Flying technique to stabilize speed :**

- Adjust pitch in order to fly the required flight path.
- When target pitch is reached, flying intended flight path, adjust thrust to target.
 - If the aircraft pitch tends to increase, aircraft is slow, then increase thrust ;
 - If the aircraft pitch tends to decrease, aircraft is fast, then decrease thrust.



R UNRELIABLE SPEED INDICATION/ADR CHECK PROC (CONT'D)

WHEN FLIGHT PATH IS STABILIZED

– PROBE/WINDOW HEAT ON

Technical recommendations :

- Respect Stall Warning
- To monitor speed, refer to IRS Ground Speed, or GPS Ground Speed variations

● **If remaining altitude indication is unreliable :**

- Do not use FPV and/or V/S, which are affected.
- ATC altitude is affected. Notify the ATC.
- Refer to GPS altitude : altitude variations may be used to control level flight, and is an altitude cue.
- Refer to Radio Altimeter.

CAUTION

If the failure is due to radome destruction, the drag will increase and therefore N1 must be increased by 5%. Fuel flow will increase by about 27%.



UNRELIABLE SPEED INDIC/ADR CHECK PROC (CONT'D)**Affected ADR identification :**

- Crosscheck all speed indications and refer to QRH 4.01 (for F, S speeds) or 5.01 (for speed in clean conf) :

■ If at least one ADR is reliable :

- Faulty ADR(s) OFF
- REMAINING AIR DATA CONFIRM
Alternates sources may be used to evaluate the air data :
 - GPS altitude
 - GPS and IRS Ground Speeds, taking into account altitude and wind effect.

■ If affected ADR(s) cannot be identified or all ADRs are affected :

- ONE ADR KEEP ON
Keep one ADR ON to maintain the STALL WARNING protection
- TWO ADRs OFF
This prevents the flight control laws from using two coherent but unreliable ADR data.
- LDG CONF USE FLAP 3
- APP SPD VLS + 10
- LDG DIST PROC APPLY
Multiply the landing distance by 1.48 on dry runway, or 1.43 on wet runway, or 1.37 on contaminated runway.

■ To return to departure airport :

Keep takeoff configuration preferably

Refer to initial and intermediate approach, and final approach tables.

■ To accelerate and clean up after takeoff :

Accelerate and clean up the aircraft in level flight :

- THRUST CLB
- FLAPS RETRACT

Retract from 3 or 2 to 1, once CLB thrust is set.

Retract from 1 to 0, when the aircraft pitch is lower than the pitch for S speed (refer to the "Pitch/Thrust for initial level off" table).

Once in clean configuration, refer to climb, cruise, descent, approach tables for flight continuation.

■ Other cases :

Refer to climb, cruise, descent, approach tables for flight continuation.



R UNRELIABLE SPEED INDICATION/ADR CHECK PROC (CONT'D)

CLIMB

Set the thrust to CL.

CLEAN				
		Above 81 t	81 t – 68 t	Below 68 t
FL	Speed	Pitch (°)/Thrust (% N1)		
Below FL 50	270 kts	8.5 / CLB	9.0 / CLB	10.0 / CLB
FL 50 – FL 100		8.0 / CLB	8.0 / CLB	9.0 / CLB
FL 100 – FL 150		7.0 / CLB	7.0 / CLB	8.0 / CLB
FL 150 – FL 200		6.0 / CLB	6.0 / CLB	6.5 / CLB
FL 200 – FL 250	300 kts	4.0 / CLB	4.0 / CLB	4.0 / CLB
FL 250 – FL 280		3.5 / CLB	3.0 / CLB	3.0 / CLB
Above FL 280	M 0.76	3.5 / CLB	3.5 / CLB	3.5 / CLB

CRUISE

Adjust N1 to maintain approximate level flight with pitch attitude held constant. When time permits, refer to QRH 5.01 (SEVERE TURBULENCE) and adjust pitch to maintain level flight.

CLEAN				
		Above 81 t	81 t – 68 t	Below 68 t
FL	Speed	Pitch (°)/Thrust (% N1)		
Below FL 200	270 kts	3.5 / 69.0	2.5 / 66.1	1.5 / 63.7
FL 200 – FL 280	300 kts	2.0 / 78.9	1.5 / 75.9	1.0 / 73.9
Above FL 280	M 0.76	2.5 / 83.7	2.5 / 81.6	2.0 / 79.0

DESCENT

Set the thrust to IDLE.

CLEAN				
		Above 81 t	81 t – 68 t	Below 68 t
FL	Speed	Pitch (°)/Thrust (% N1)		
Above FL 280	M 0.76	-1.0 / IDLE	-1.5 / IDLE	-2.0 / IDLE
FL 280 – FL 200	300 kts	-0.5 / IDLE	-1.5 / IDLE	-2.5 / IDLE
FL 200 – FL 100	270 kts	0.5 / IDLE	-0.5 / IDLE	-1.5 / IDLE
Below FL 100	270 kts	0.5 / IDLE	-0.5 / IDLE	-2.0 / IDLE
Below FL 100	G-DOT	2.0 / IDLE	2.0 / IDLE	2.0 / IDLE



UNRELIABLE SPEED INDIC/ADR CHECK PROC (CONT'D)**Affected ADR identification :**

- Crosscheck all speed indications and refer to QRH 4.01 (for F, S speeds) or 5.01 (for speed in clean conf) :

■ If at least one ADR is reliable :

- Faulty ADR(s) OFF
- REMAINING AIR DATA CONFIRM
Alternates sources may be used to evaluate the air data :
 - GPS altitude
 - GPS and IRS Ground Speeds, taking into account altitude and wind effect.

■ If affected ADR(s) cannot be identified or all ADRs are affected :

- ONE ADR KEEP ON
Keep one ADR ON to maintain the STALL WARNING protection
- TWO ADRs OFF
This prevents the flight control laws from using two coherent but unreliable ADR data.
- LDG CONF USE FLAP 3
- APP SPD VLS + 10
- LDG DIST PROC APPLY
Multiply the landing distance by 1.48 on dry runway, or 1.43 on wet runway, or 1.37 on contaminated runway.

■ To return to departure airport :

Keep takeoff configuration preferably
Refer to initial and intermediate approach, and final approach tables.

■ To accelerate and clean up after takeoff :

Accelerate and clean up the aircraft in level flight :

- THRUST CLB
- FLAPS RETRACT

Retract from 3 or 2 to 1, once CLB thrust is set.
Retract from 1 to 0, when the aircraft pitch is lower than the pitch for S speed (refer to the "Pitch/Thrust for initial level off" table).
Once in clean configuration, refer to climb, cruise, descent, approach tables for flight continuation.

■ Other cases :

Refer to climb, cruise, descent, approach tables for flight continuation.



R UNRELIABLE SPEED INDICATION/ADR CHECK PROC (CONT'D)

CLIMB

Set the thrust to CL.

CLEAN				
		Above 67 t	67 t – 57 t	Below 57 t
FL	Speed	Pitch (°)/Thrust (% N1)		
Below FL 50	250 kts	10.0 / CLB	10.5 / CLB	11.5 / CLB
FL 50 – FL 100		9.0 / CLB	9.5 / CLB	10.0 / CLB
FL 100 – FL 150		8.0 / CLB	8.5 / CLB	8.5 / CLB
FL 150 – FL 200		7.0 / CLB	7.0 / CLB	7.0 / CLB
FL 200 – FL 250	275 kts	5.0 / CLB	5.0 / CLB	5.0 / CLB
FL 250 – FL 320		4.0 / CLB	4.0 / CLB	4.0 / CLB
Above FL 320	M 0.76	3.5 / CLB	3.5 / CLB	3.5 / CLB

CRUISE

Adjust N1 to maintain approximate level flight with pitch attitude held constant. When time permits, refer to QRH 5.01 (SEVERE TURBULENCE) and adjust pitch to maintain level flight.

CLEAN				
		Above 67 t	67 t – 57 t	Below 57 t
FL	Speed	Pitch (°)/Thrust (% N1)		
Below FL 200	250 kts	4.0 / 62.4	3.0 / 60.1	2.0 / 58.3
FL 200 – FL 320	275 kts	3.0 / 73.4	2.0 / 71.6	1.5 / 70.2
Above FL 320	M 0.76	2.5 / 79.2	2.5 / 78.1	2.0 / 77.0

DESCENT

Set the thrust to IDLE.

CLEAN				
		Above 67 t	67 t – 57 t	Below 57 t
FL	Speed	Pitch (°)/Thrust (% N1)		
Above FL 320	M 0.76	-0.5 / IDLE	-1.0 / IDLE	-1.5 / IDLE
FL 320 – FL 200	275 kts	0.0 / IDLE	-0.5 / IDLE	-1.5 / IDLE
FL 200 – FL 100	250 kts	1.5 / IDLE	0.5 / IDLE	-0.5 / IDLE
Below FL 100	250 kts	1.0 / IDLE	0.0 / IDLE	-1.0 / IDLE
Below FL 100	G-DOT	2.0 / IDLE	2.5 / IDLE	2.5 / IDLE



UNRELIABLE SPEED INDIC/ADR CHECK PROC (CONT'D)**Affected ADR identification :**

- Crosscheck all speed indications and refer to QRH 4.01 (for F, S speeds) or 5.01 (for speed in clean conf) :

■ If at least one ADR is reliable :

- Faulty ADR(s) OFF
- REMAINING AIR DATA CONFIRM
Alternates sources may be used to evaluate the air data :
 - GPS altitude
 - GPS and IRS Ground Speeds, taking into account altitude and wind effect.

■ If affected ADR(s) cannot be identified or all ADRs are affected :

- ONE ADR KEEP ON
Keep one ADR ON to maintain the STALL WARNING protection
- TWO ADRs OFF
This prevents the flight control laws from using two coherent but unreliable ADR data.
- LDG CONF USE FLAP 3
- APP SPD VLS + 10
- LDG DIST PROC APPLY
Multiply the landing distance by 1.48 on dry runway, or 1.48 on wet runway, or 1.43 on contaminated runway.

■ To return to departure airport :

Keep takeoff configuration preferably

Refer to initial and intermediate approach, and final approach tables.

■ To accelerate and clean up after takeoff :

Accelerate and clean up the aircraft in level flight :

- THRUST CLB
- FLAPS RETRACT

Retract from 3 or 2 to 1, once CLB thrust is set.

Retract from 1 to 0, when the aircraft pitch is lower than the pitch for S speed (refer to the "Pitch/Thrust for initial level off" table).

Once in clean configuration, refer to climb, cruise, descent, approach tables for flight continuation.

■ Other cases :

Refer to climb, cruise, descent, approach tables for flight continuation.



R UNRELIABLE SPEED INDICATION/ADR CHECK PROC (CONT'D)

CLIMB

Set the thrust to CL.

CLEAN				
		Above 66 t	66 t – 56 t	Below 56 t
FL	Speed	Pitch (°)/Thrust (% N1)		
Below FL 50	250 kts	10.5 / CLB	11.5 / CLB	12.5 / CLB
FL 50 – FL 100		9.5 / CLB	10.0 / CLB	11.0 / CLB
FL 100 – FL 150		8.5 / CLB	8.5 / CLB	9.5 / CLB
FL 150 – FL 200	275 kts	7.5 / CLB	7.5 / CLB	8.0 / CLB
FL 200 – FL 250		5.0 / CLB	5.0 / CLB	5.0 / CLB
FL 250 – FL 320		4.0 / CLB	4.0 / CLB	4.0 / CLB
Above FL 320	M 0.76	3.5 / CLB	4.0 / CLB	4.0 / CLB

CRUISE

Adjust N1 to maintain approximate level flight with pitch attitude held constant. When time permits, refer to QRH 5.01 (SEVERE TURBULENCE) and adjust pitch to maintain level flight.

CLEAN				
		Above 66 t	66 t – 56 t	Below 56 t
FL	Speed	Pitch (°)/Thrust (% N1)		
Below FL 200	250 kts	3.5 / 62.4	3.0 / 60.3	2.0 / 58.8
FL 200 – FL 320	275 kts	2.5 / 74.3	2.0 / 72.7	1.5 / 71.4
Above FL 320	M 0.76	3.0 / 80.1	2.5 / 78.6	2.0 / 76.3

DESCENT

Set the thrust to IDLE.

CLEAN				
		Above 66 t	66 t – 56 t	Below 56 t
FL	Speed	Pitch (°)/Thrust (% N1)		
Above FL 320	M 0.76	-0.5 / IDLE	-0.5 / IDLE	-1.5 / IDLE
FL 320 – FL 200	275 kts	0.0 / IDLE	-1.0 / IDLE	-2.0 / IDLE
FL 200 – FL 100	250 kts	1.0 / IDLE	0.0 / IDLE	-1.0 / IDLE
Below FL 100	250 kts	1.0 / IDLE	0.0 / IDLE	-1.0 / IDLE
Below FL 100	G-DOT	2.5 / IDLE	2.5 / IDLE	2.5 / IDLE



R UNRELIABLE SPEED INDICATION/ADR CHECK PROC (CONT'D)

INITIAL AND INTERMEDIATE APPROACH IN LEVEL FLIGHT

R The approach phase between Green Dot speed (clean configuration) and the landing configuration (CONF 3), is flown in level flight.

LANDING GEAR UP IN LEVEL FLIGHT

CONF	Speed (kts)	Above 81 t	81 t – 68 t	Below 68 t
		Pitch (°)/Thrust (% N1)		
0	G-DOT	5.0 / 63.4	5.0 / 59.4	5.0 / 54.6
1	S	7.5 / 65.6	7.5 / 61.4	7.5 / 56.6
1+F (a)	S	3.5 / 67.6	3.0 / 63.8	3.0 / 58.6
2	F	7.0 / 68.5	7.0 / 64.7	7.0 / 59.9

LANDING GEAR DOWN IN LEVEL FLIGHT
(EXPECT GRVTY EXTENSION)

3	F	4.0 / 74.8	4.0 / 71.0	4.0 / 65.8
---	---	------------	------------	------------

(a) Due to the fact that the speed is unreliable, the SFCC may select the 1+F configuration in approach, instead of 1.

FINAL APPROACH AT STANDARD – 3° DESCENT FLIGHT PATH

LANDING GEAR DOWN

CONF	Speed (kts)	Above 81 t	81 t – 68 t	Below 68 t
		Pitch (°)/Thrust (% N1)		
3	VLS+10	2.0 / 60.0	2.0 / 56.0	1.5 / 51.6

Flying technique to stabilize speed :

- Adjust pitch in order to fly the required flight path.
- When target pitch is reached, flying intended flight path, adjust thrust to target.
 - If the aircraft pitch tends to increase, aircraft is slow, then increase thrust ;
 - If the aircraft pitch tends to decrease, aircraft is fast, then decrease thrust.

R UNRELIABLE SPEED INDICATION/ADR CHECK PROC (CONT'D)

INITIAL AND INTERMEDIATE APPROACH IN LEVEL FLIGHT

R The approach phase between Green Dot speed (clean configuration) and the landing configuration (CONF 3), is flown in level flight.

LANDING GEAR UP IN LEVEL FLIGHT

CONF	Speed (kts)	Above 66 t	66 t – 56 t	Below 56 t
		Pitch (°)/Thrust (% N1)		
0	G-DOT	5.0 / 57.0	5.5 / 53.1	5.5 / 49.4
1	S	7.5 / 59.2	7.5 / 55.5	7.5 / 51.1
1+F (a)	S	3.5 / 62.5	3.5 / 58.5	3.5 / 54.2
2	F	8.5 / 61.2	8.5 / 57.0	8.5 / 52.6

LANDING GEAR DOWN IN LEVEL FLIGHT
(EXPECT GRVTY EXTENSION)

3	F	7.5 / 66.6	7.0 / 62.6	7.0 / 58.0
---	---	------------	------------	------------

(a) Due to the fact that the speed is unreliable, the SFCC may select the 1+F configuration in approach, instead of 1.

FINAL APPROACH AT STANDARD – 3° DESCENT FLIGHT PATH

LANDING GEAR DOWN

CONF	Speed (kts)	Above 66 t	66 t – 56 t	Below 56 t
		Pitch (°)/Thrust (% N1)		
3	VLS+10	4.5 / 49.9	4.5 / 47.2	4.0 / 43.9

Flying technique to stabilize speed :

- Adjust pitch in order to fly the required flight path.
- When target pitch is reached, flying intended flight path, adjust thrust to target.
 - If the aircraft pitch tends to increase, aircraft is slow, then increase thrust ;
 - If the aircraft pitch tends to decrease, aircraft is fast, then decrease thrust.

R UNRELIABLE SPEED INDICATION/ADR CHECK PROC (CONT'D)

INITIAL AND INTERMEDIATE APPROACH IN LEVEL FLIGHT

R The approach phase between Green Dot speed (clean configuration) and the landing configuration (CONF 3), is flown in level flight.

R LANDING GEAR UP IN LEVEL FLIGHT

CONF	Speed (kts)	Above 67 t	67 t – 57 t	Below 57 t
		Pitch (°)/Thrust (% N1)		
0	G-DOT	5.5 / 55.7	5.5 / 51.5	6.0 / 47.3
1	S	7.5 / 58.2	7.5 / 54.0	7.5 / 49.0
1+F (a)	S	4.5 / 60.2	4.5 / 56.1	4.5 / 51.2
2	F	9.0 / 61.7	9.0 / 57.3	9.0 / 52.8

LANDING GEAR DOWN IN LEVEL FLIGHT
(EXPECT GRVTY EXTENSION)

3	F	7.5 / 67.2	7.5 / 62.7	7.5 / 57.9
---	---	------------	------------	------------

(a) Due to the fact that the speed is unreliable, the SFCC may select the 1+F configuration in approach, instead of 1.

FINAL APPROACH AT STANDARD – 3° DESCENT FLIGHT PATH

LANDING GEAR DOWN

CONF	Speed (kts)	Above 67t	67t – 55t	Below 57t
		Pitch (°)/Thrust (% N1)		
3	VLS+10	4.5 / 48.0	4.5 / 44.4	4.5 / 41.4

Flying technique to stabilize speed :

- Adjust pitch in order to fly the required flight path.
- When target pitch is reached, flying intended flight path, adjust thrust to target.
 - If the aircraft pitch tends to increase, aircraft is slow, then increase thrust ;
 - If the aircraft pitch tends to decrease, aircraft is fast, then decrease thrust.

NAV FM/GPS POS DISAGREE

This message is triggered when either one of the FM positions differs from either of the GPS positions by more than 0.5 minutes of latitude or longitude.

– A/C POS CHECK

The following procedure is not displayed on the ECAM

● If the message occurs during takeoff initiation:

– Continue takeoff and monitor navigation.

● If the message occurs during ILS/LOC approach (LOC green):

– DISREGARD it.

● If the message occurs in climb, cruise, or descent:

– CHECK navigation accuracy, using raw data:

■ If the check is positive:

– NAV mode and ND ARC/ROSE NAV may be used.

■ If the check is negative:

– HDG/TRK mode and raw data must be used.

– Consider switching off the terrain functions of the EGPWS.

– When possible, compare the FM position versus the GPIRS position on the POSITION MONITOR page:

■ If one FM position agrees with the GPIRS position on the POSITION MONITOR page:

– Use the associated FD/AP.

■ If not :

– Deselect the GPS, and revert to basic information.

● If the message occurs during a Non Precision Approach (NPA):

■ Overlay approach:

– SELECT HDG or TRK, and use raw data

■ GPS or RNAV approach:

– GO AROUND or fly visual, if visual conditions are met.

R
R
R
R

ADR 1+2+3 FAULT

This procedure is not displayed on the ECAM. Only dual ADR warnings are displayed, in case of a triple ADR failure.

- ADR (all) OFF
- STBY INST (ALT + ASI) USE

NOTE : Disregard ECAM actions for AIR DATA SWTG and ATC, since these have no effect in case of a total loss of ADRs.

F/CTL ALTN LAW (PROT LOST)

NOTE : The STALL WARNING is lost.

- MAX SPEED 320/.82
- See the following table for the IAS/M relationship for .82.

FL	390	370	350	330	310	290	280 and below
MAX SPD	252	265	278	290	305	315	320

- WHEN L/G DN : DIRECT LAW

At landing gear extension, control reverts to direct law in pitch, as well as in roll.

NOTE : Use manual control of cabin pressurization (Refer to 3.02.21) :

- MODE SEL MAN
- MAN V/S CTL AS RQD

STATUS

MAX SPEED 320/.82
 RUD WITH CARE ABV 160 KT

At slats' extension, full rudder travel authority is recovered.

APPR PROC :

- FOR LDG USE FLAP 3
 - GPWS LDG FLAP 3 ON
 - APPR SPD VREF + 10 KT
 - LDG DIST PROC APPLY
- Multiply the landing distance by 1.35 on dry runway, or 1.30 on wet runway, or 1.25 on contaminated runway.*
- CAT 1 ONLY

● **FOR L/G GRVTY EXTN (not on the ECAM) :**

- GRVTY GEAR EXTN handcrank PULL AND TURN
 - L/G LEVER DOWN
- WHEN L/G DN : DIRECT LAW

● **DURING FINAL APPR**

- V/S CTL FULL UP

NOTE 1 : In case of a go-around, respect maximum speed 215 knots in CONF 1+F, due to the loss of flap auto retraction to CONF 1.

INOP SYS

- ATT LIMIT
- OVSP LIMIT
- ALPHA LIMIT
- ADR 1+2+3
- WINDSHEAR DET
- RUD TRV LIM 1+2
- A/THR
- AP 1+2
- GPWS

Other inop sys :
 See below

CAUTION

Check that the outflow valve is fully open, and that cabin altitude is at airfield elevation before opening the doors.

R
R

Other inoperative systems

CAB PR 1+2
 RAT auto extension

ATC ALTI MODE

TCAS 
 L/G RETRACT

NAV FM/GPS POS DISAGREE

The FMS and GPS positions differ by more than a longitude threshold that depends on the latitude :

- 0.5 minutes for latitudes below 55°
- 0.9 minutes for latitudes at, or above, 55° and below 70°
- or a latitude threshold of 0.5 minutes, regardless of the latitude.
- A/C POS CHECK

The following procedure is not displayed on the ECAM:

- R
R
R
R
- **If the message occurs during takeoff initiation:**
 - Continue takeoff and monitor navigation.
 - **If the message occurs during ILS/LOC approach (LOC green):**
 - DISREGARD it.
 - **If the message occurs in climb, cruise, or descent:**
 - CHECK navigation accuracy, using raw data:
 - **If the check is positive:**
 - NAV mode and ND ARC/ROSE NAV may be used.
 - **If the check is negative:**
 - HDG/TRK mode and raw data must be used.
 - Consider switching off the terrain functions of the EGPWS.
 - When possible, compare the FM position with the GPIRS position, on the POSITION MONITOR page:
 - **If one FM position agrees with the GPIRS position, on the POSITION MONITOR page:**
 - Use the associated FD/AP.
 - **If not:**
 - Deselect the GPS, and revert to basic information.
 - **If the message occurs during a Non Precision Approach (NPA):**
 - **Overlay approach:**
 - SELECT HDG or TRK, and use raw data
 - **GPS or RNAV approach:**
 - GO AROUND or fly visual, if visual conditions are met.

ADR 1+2+3 FAULT

This procedure is not displayed on the ECAM. Only dual ADR warnings are displayed, in case of a triple ADR failure.

- ADR (all) OFF
- STBY INST (ALT + ASI) USE

NOTE : Disregard ECAM actions for AIR DATA SWTG and ATC, since these have no effect in case of a total loss of ADRs.

F/CTL ALTN LAW (PROT LOST)

NOTE : The STALL WARNING is lost.

- MAX SPEED 320/.82
- See the following table for the IAS/M relationship for .82.

FL	390	370	350	330	310	290	280 and below
MAX SPD	252	265	278	290	305	315	320

- WHEN L/G DN : DIRECT LAW

At landing gear extension, control reverts to direct law in pitch, as well as in roll.

NOTE : Use manual control of cabin pressurization (Refer to 3.02.21) :

- MODE SEL MAN
- MAN V/S CTL AS RQD

STATUS

MAX SPEED 320/.82
 RUD WITH CARE ABV 160 KT

At slats' extension, full rudder travel authority is recovered.

APPR PROC :

- FOR LDG USE FLAP 3
 - GPWS LDG FLAP 3 ON
 - APPR SPD VREF + 10 KT
 - LDG DIST PROC APPLY
- Multiply the landing distance by 1.35 on dry runway, or 1.30 on wet runway, or 1.25 on contaminated runway.
- CAT 1 ONLY

● **FOR L/G GRVTY EXTN (not on the ECAM) :**

- GRVTY GEAR EXTN handcrank PULL AND TURN
 - L/G LEVER DOWN
- WHEN L/G DN : DIRECT LAW

● **DURING FINAL APPR**

- V/S CTL FULL UP

NOTE 1 : In case of a go-around, respect maximum speed 215 knots in CONF 1+F, due to the loss of flap auto retraction to CONF 1.

INOP SYS

- ATT LIMIT
- OVSP LIMIT
- ALPHA LIMIT
- ADR 1+2+3
- WINDSHEAR DET
- RUD TRV LIM 1+2
- A/THR
- AP 1+2
- GPWS

Other inop sys :
 See below

CAUTION

Check that the outflow valve is fully open, and that cabin altitude is at airfield elevation before opening the doors.

R
R

Other inoperative systems

CAB PR 1+2
 RAT auto extension

ATC ALTI MODE

TCAS 
 L/G RETRACT

NAV FM/GPS POS DISAGREE

The FMS and GPS positions differ by more than a longitude threshold that depends on the latitude :

- 0.5 minutes for latitudes below 55°
- 0.9 minutes for latitudes at, or above, 55° and below 70°
- or a latitude threshold of 0.5 minutes, regardless of the latitude.
- A/C POS CHECK

The following procedure is not displayed on the ECAM:

- R
R
R
R
- **If the message occurs during takeoff initiation:**
 - Continue takeoff and monitor navigation.
 - **If the message occurs during ILS/LOC approach (LOC green):**
 - DISREGARD it.
 - **If the message occurs in climb, cruise, or descent:**
 - CHECK navigation accuracy, using raw data:
 - **If the check is positive:**
 - NAV mode and ND ARC/ROSE NAV may be used.
 - **If the check is negative:**
 - HDG/TRK mode and raw data must be used.
 - Consider switching off the terrain functions of the EGPWS.
 - When possible, compare the FM position with the GPIRS position, on the POSITION MONITOR page:
 - **If one FM position agrees with the GPIRS position, on the POSITION MONITOR page:**
 - Use the associated FD/AP.
 - **If not:**
 - Deselect the GPS, and revert to basic information.
 - **If the message occurs during a Non Precision Approach (NPA):**
 - **Overlay approach:**
 - SELECT HDG or TRK, and use raw data
 - **GPS or RNAV approach:**
 - GO AROUND or fly visual, if visual conditions are met.

ADR 1+2+3 FAULT

This procedure is not displayed on the ECAM. Only dual ADR warnings are displayed, in case of a triple ADR failure.

- ADR (all) OFF
- STBY INST (ALT + ASI) USE

NOTE : Disregard ECAM actions for AIR DATA SWTG and ATC, since these have no effect in case of a total loss of ADRs.

F/CTL ALTN LAW (PROT LOST)

NOTE : The STALL WARNING is lost.

- MAX SPEED 320/.82
- See the following table for the IAS/M relationship for .82.*

FL	390	370	350	330	310	290	280 and below
MAX SPD	252	265	278	290	305	315	320

- WHEN L/G DN : DIRECT LAW

At landing gear extension, control reverts to direct law in pitch, as well as in roll.

NOTE : Use manual control of cabin pressurization (Refer to 3.02.21) :

- MODE SEL MAN
- MAN V/S CTL AS RQD

STATUS

MAX SPEED 320/.82

RUD WITH CARE ABV 160 KT

At slats' extension, full rudder travel authority is recovered.

APPR PROC :

- FOR LDG USE FLAP 3
- GPWS LDG FLAP 3 ON

APPR SPD V_{REF} + 10 KT

- LDG DIST PROC APPLY

Multiply the landing distance by 1.35 on dry runway, or 1.35 on wet runway, or 1.30 on contaminated runway.

CAT 1 ONLY

- **FOR L/G GRVTY EXTN (not on the ECAM) :**

- GRVTY GEAR EXTN handcrank PULL AND TURN
- L/G LEVER DOWN
- WHEN L/G DN : DIRECT LAW

- **DURING FINAL APPR**

- V/S CTL FULL UP

NOTE 1 : In case of a go-around, respect maximum speed 215 knots in CONF 1+F, due to the loss of flap auto retraction to CONF 1.

CAUTION

Check that the outflow valve is fully open, and that cabin altitude is at airfield elevation before opening the doors.

Other inoperative systems

CAB PR 1+2
RAT auto extension

ATC ALTI MODE

TCAS  L/G RETRACT

R
R

NAV FM/GPS POS DISAGREE

The FMS and GPS positions differ by more than a longitude threshold that depends on the latitude :

- 0.5 minutes for latitudes below 55 deg
- 0.9 minutes for latitudes at, or above, 55 deg and below 70 deg
- or a latitude threshold of 0.5 minutes, regardless of the latitude.
- A/C POS CHECK

The following procedure is not displayed on the ECAM:

- R
R
R
R
- **If the message occurs during takeoff initiation:**
 - Continue takeoff and monitor navigation.
 - **If the message occurs during ILS/LOC approach (LOC green):**
 - DISREGARD it.
 - **If the message occurs in climb, cruise, or descent:**
 - CHECK navigation accuracy, using raw data:
 - **If the check is positive:**
 - NAV mode and ND ARC/ROSE NAV may be used.
 - **If the check is negative:**
 - HDG/TRK mode and raw data must be used.
 - Consider switching off the terrain functions of the GPWS.
 - When possible, compare the FM position with the GPIRS position, on the POSITION MONITOR page:
 - **If one FM position agrees with the GPIRS position, on the POSITION MONITOR page:**
 - Use the associated FD/AP.
 - **If not:**
 - Deselect the GPS, and revert to basic information.
 - **If the message occurs during a Non Precision Approach (NPA):**
 - **Overlay approach:**
 - SELECT HDG or TRK, and use raw data
 - **GPS or RNAV approach:**
 - GO AROUND or fly visual, if visual conditions are met.

ADR 1+2+3 FAULT

This procedure is not displayed on the ECAM. Only dual ADR warnings are displayed, in case of a triple ADR failure.

- ADR (all) OFF
- STBY INST (ALT + ASI) USE

NOTE : Disregard ECAM actions for AIR DATA SWTG and ATC, since these have no effect in case of a total loss of ADRs.

F/CTL ALTN LAW (PROT LOST)

- MAX SPEED 320/.82
- See the following table for the IAS/M relationship for .82.

FL	390	370	350	330	310	290	280 and below
MAX SPD	252	265	278	290	305	315	320

- WHEN L/G DN : DIRECT LAW

At landing gear extension, control reverts to direct law in pitch, as well as in roll.

NOTE : Use manual control of cabin pressurization (Refer to 3.02.21) :

- MODE SEL MAN
- MAN V/S CTL AS RQD

STATUS

MAX SPEED 320/.82
 RUD WITH CARE ABV 160 KT

At slats' extension, full rudder travel authority is recovered.

APPR PROC :

- FOR LDG USE FLAP 3
- GPWS LDG FLAP 3 ON

APPR SPD V_{REF} + 10 KT

- LDG DIST PROC APPLY
- Multiply the landing distance by 1.35 on dry runway or 1.30 on wet runway or 1.25 on contaminated runway.

CAT 1 ONLY

● **FOR L/G GRVTY EXTN (not on the ECAM) :**

- GRVTY GEAR EXTN handcrank PULL AND TURN
 - L/G LEVER DOWN
- WHEN L/G DN : DIRECT LAW

● **DURING FINAL APPR**

- V/S CTL FULL UP

NOTE 1 : In case of a go-around, respect maximum speed 215 knots in CONF 1+F, due to the loss of flap auto retraction to CONF 1.

CAUTION

Check the outflow valve is fully open, and that cabin altitude is at airfield elevation before opening the doors.

Other inoperative systems

CAB PR 1+2

ATC ALTI MODE

TCAS  L/G RETRACT

RAT automatic extension is lost.

R
R

R

NAV IR ALIGNMENT IN ATT MODE

If IR alignment is lost, the navigation mode is inoperative (red ATT flag on the PFD, and red HDG flag on the ND).

Aircraft attitude and heading may be recovered by applying the following procedure. The aircraft must stay level, with constant speed for 30 seconds.

- MODE SELECTOR ATT
ALIGN light on for 30 seconds.
ATT MODE displayed on the CDU.
- LEVEL A/C ATTITUDE HOLD
- CONSTANT A/C SPEED MAINTAIN
- DISPLAY SYS switch AFFECTED SYS
- DISPLAY DATA switch HDG

Depending on the CDU keyboard installed, an "H" may be written on the "5" key :

■ **If "H" is written on the "5" key :**

- H KEY PRESS
Degree marker, 0 decimal point, ENT and CLR lights come on.
- A/C HEADING ENTER

■ **If "H" is not written on the "5" key :**

- A/C HEADING ENTER
Enter the aircraft's magnetic heading on the CDU keyboard.
Then, press the ENT key to enter data.
Example : To enter a heading of 320°, dial 3, 2, 0, 0 then press ENT.
Heading will be displayed on the associated ND.
"HDG---ATT MODE" will be displayed on the CDU.
Due to IR drift, the magnetic heading has to be periodically crosschecked and updated with standby compass, if required.

R

ENG RELIGHT (in flight)

- MAX ALTITUDE See below
- ENG MASTER (affected) OFF
- THR LEVER (affected) IDLE
- MAN START pushbutton OFF

Autostart is recommended in flight. Be aware that contrary to an autostart on ground, the crew must take appropriate action in case of an abnormal start.

- ENG MODE SEL IGN
- X BLEED OPEN
- WING A. ICE (for starter assist) OFF
- ENG MASTER (affected) ON

Engine light-up must be achieved within 30 seconds after fuel flow increases.

■ When idle is reached :

- ENG MODE SEL NORM
- TCAS MODE SEL ◁ check TA/RA

Check that the selector is at TA/RA since, if the ENG SHUT DOWN procedure has been applied, the TCAS mode selector may have been set at the TA position.

- Affected SYS RESTORE

■ If no relight :

- ENG MASTER (affected) OFF

Wait 30 seconds before attempting a new start (to drain the engine).

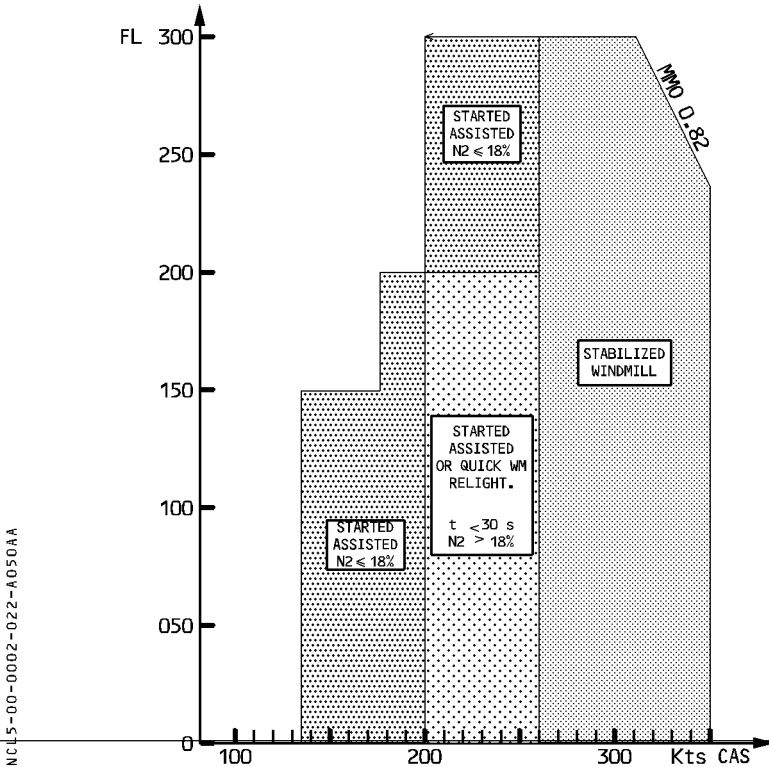

NAV IR ALIGNMENT IN ATT MODE

If IR alignment is lost, the navigation mode is inoperative (red ATT flag on the PFD and red HDG flag on the ND).

Aircraft attitude and heading may be recovered by applying the following procedure. The aircraft must stay level, with constant speed for 30 seconds.

- MODE SELECTOR ATT
ALIGN light on for 30 seconds.
ATT MODE displayed on the CDU.
- LEVEL A/C ATTITUDE HOLD
- CONSTANT A/C SPEED MAINTAIN
- DISPLAY SYS switch AFFECTED SYS
- DISPLAY DATA switch HDG

■ MCDU INITIALIZATION :

- DATA (MCDU KEY) PRESS
The DATA INDEX page is displayed.
- IRS MONITOR (2L KEY) PRESS
The IRS MONITOR page is displayed.
- A/C HEADING ENTER
The heading must be entered in the SET HDG field (5R KEY).

■ CDU INITIALIZATION :

Depending on the CDU keyboard installed, an "H" may be written on the "5" key :

■ If "H" is written on the "5" key :

- H KEY PRESS
Degree marker, 0 decimal point, ENT and CLR lights come on.
- A/C HEADING ENTER

■ If "H" is not written on the "5" key :

- A/C HEADING ENTER

Enter the aircraft's magnetic heading on the CDU keyboard. Then, press the ENT key to enter data.

Example : To enter a heading of 320°, dial 3, 2, 0, 0 then press ENT.

Heading will be displayed on the associated ND.

"HDG---ATT MODE" will be displayed on the CDU.

Due to IR drift, the magnetic heading has to be periodically crosschecked and updated with standby compass, if required.

ENG RELIGHT (in flight)

- MAX ALTITUDE See below
- ENG MASTER (affected) OFF
- THR LEVER (affected) IDLE
- MAN START pushbutton OFF

Autostart is recommended in flight. Be aware that contrary to an autostart on ground, the crew must take appropriate action in case of an abnormal start.

- ENG MODE SEL IGN
- X BLEED OPEN
- WING A. ICE (for starter assist) OFF
- ENG MASTER (affected) ON

Engine light-up must be achieved within 30 seconds after fuel flow increases.

■ **When idle is reached :**

- ENG MODE SEL NORM
- TCAS MODE SEL ◀ check TA/RA

Check that the selector is at TA/RA since, if the ENG SHUT DOWN procedure has been applied, the TCAS mode selector may have been set at the TA position.

- Affected SYS RESTORE

■ **If no relight :**

- ENG MASTER (affected) OFF

Wait 30 seconds before attempting a new start (to drain the engine).

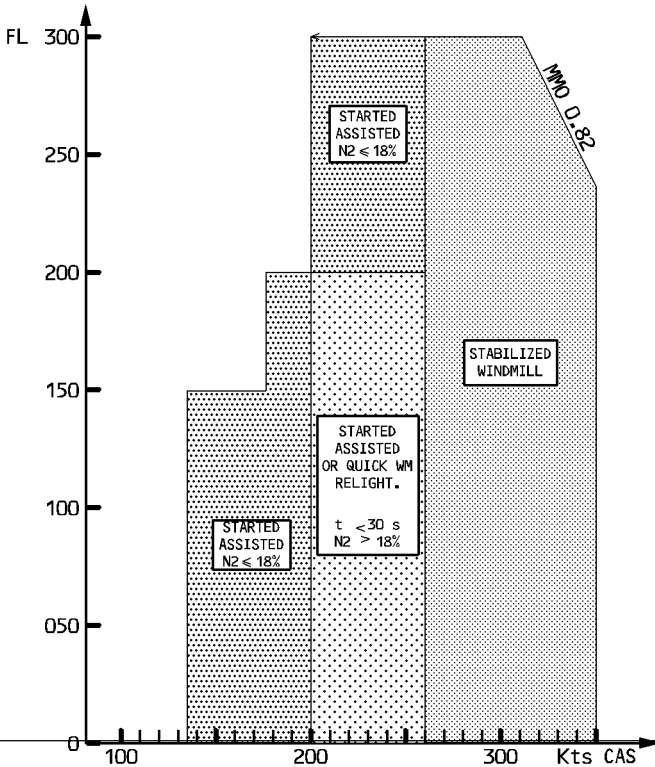

NCL5-00-0002-022-A050AA

Code : 0011

ENG 1 (2) STALL

■ On ground :

- ENG MASTER (affected engine) OFF

■ In flight :

Only ENG 1 (2) STALL is displayed on ECAM.

The following procedure is not displayed :

- THR LEVER (affected engine) IDLE
- ENG PARAMETERS (affected engine) CHECK

● Abnormal :

- ENG MASTER (affected engine) OFF

ENG 1 (2) SHUT DOWN

● Normal :

- ENG A.ICE (affected engine) ON
- WING A.ICE ON
- THR LEVER (affected engine) SLOWLY ADVANCE

● If a stall recurs :

- THR LEVER (affected engine) REDUCE

● If a stall does not recur :

Continue engine operation.

APPROACH WITH ONE ENGINE INOPERATIVE

*For performance reasons, do not extend flap full until established on a final descent to landing.
If a level off is expected during final approach, perform the approach and landing in CONF 3.*

ENG TAILPIPE FIRE

CAUTION

External fire agents can cause severe corrosive damage and should, therefore, only be considered after having applied following procedure :

- MAN START OFF
- ENG MASTER (affected) OFF
- AIR BLEED PRESS ESTABLISH
- BEACON ON
- ENG MODE SEL CRANK
- MAN START ON

● When burning has stopped :

- MAN START OFF
- ENG MODE SEL NORM

R

HIGH ENGINE VIBRATION

■ High N2 vibrations during engine start on ground :

Engine start should be aborted (if vibration indications are available), when the N2 vibration level exceeds the 6.5-units advisory threshold. The subsequent start is to be initiated after the engine has completely spooled down. This procedure may be repeated a maximum of three times. Report any N2 vibration advisory condition in the logbook.

■ High N1 or N2 vibrations in operation :

The ECAM's VIB advisory (N1 ≥ 5 units, N2 ≥ 5 units) is mainly a guideline to induce the crew to monitor engine parameters more closely.

VIB detection alone does not require engine shutdown.

- NOTE : 1. High engine vibrations may be accompanied by cockpit and cabin smoke, and/or the smell of burning. This may be due only to compressor blade tip contact with associated abradable seals.
2. High N₁ vibrations are generally accompanied by perceivable airframe vibrations.
High N₂ vibrations can occur without perceivable airframe vibrations.

■ If no icing conditions :

ENG PARAMETERS CHECK

*Check engine parameters and especially EGT ; crosscheck with the other engine.
Report in the maintenance log.*

● If rapid increase above the advisory :

- **THRUST LEVER (affected engine) RETARD**
Flight conditions permitting, reduce N1 to maintain the vibration level below the advisory threshold.

NOTE : *If the VIB indication does not decrease following thrust reduction, this may indicate other engine problems. Apply the adequate procedure.*

■ If icing conditions :

An increase in engine vibrations in icing conditions, with or without engine anti-ice, may be due to fan blades and/or spinner icing.

- **A/THR OFF**
- **ENGINE ANTI-ICE CHECK**

If ENG ANTI-ICE is off, switch it ON at idle fan speed, one engine after the other at an approximate 30-second interval.

- **THRUST LEVER (one engine at a time) .. INCREASE THRUST**

*Increase thrust to a setting compatible with the flight phase. The VIB level will return to normal after ice has been shed, despite a slight increase during acceleration.
Resume normal operation.*

NOTE : *When vibrations above the advisory level have been experienced during the flight, and if possible, shut down the engine after landing, for taxiing.*

OVERWEIGHT LANDING

– LDG CONF AS REQUIRED

Use the ECAM flap setting, if required for abnormal operations. In all other cases :

- FULL is preferred for optimized landing performance.
- If the aircraft weight is above the maximum weight for go-around (given in the table below), use FLAP 3 for landing.

In all cases, if landing configuration is different from FLAP FULL, use 1+F for go-around.

NOTE : At very high weights, VFE CONF1 is close to VLS clean. To select CONF1, deselect A/THR, decelerate to (or slightly below) VLS and select CONF1 when below VFE. When established at CONF1, the crew can re-engage the A/THR and use managed speed again.

– LDG DIST CHECK

– PACK 1 and 2 OFF or supplied by APU

Selecting packs OFF (or supplied from APU) will increase the maximum thrust available from the engines, in the event of a go-around.

● In the final approach stages

– TARGET SPEED VLS

Reduce the selected speed on the FCU to reach VLS at runway threshold.
Touch down as smoothly as possible (Maximum V/S at touchdown 360 ft/min).

● At main landing gear touchdown

– REVERSE THRUST USE MAX AVAILABLE

● After nosewheel touchdown

– BRAKES APPLY AS NECESSARY

Maximum braking may be used after nosewheel touchdown. But, if landing distance permits, delay or reduce braking to fully benefit from the available runway length.

● Landing complete

– BRAKE FANS (◀) ON

Be prepared for tire deflation, if temperatures exceed 800° C.

MAXIMUM WEIGHT FOR GO AROUND IN CONF 3 (1000 kg)								
OAT °C	AIRPORT ELEVATION (FT)							
	0	2000	4000	6000	8000	10000	12000	14000
<10	92	88	82	76	70	65	60	55
15	92	88	82	76	70	65	60	55
20	92	88	82	76	70	65	60	55
25	92	87	80	75	69	64	59	
30	92	85	79	73	68			
35	88	82	76	70	65			
40	85	79	73	68				
45	82	75	70					
50	78	72						
55								

R
R
R
R
R
R
R
R
R
R

COCKPIT WINDSHIELD/WINDOW CRACKED

- MAX FL 230
- CAB PRESS MODE SEL MAN
- MAN V/S CTL AS RQRD

Set the cabin altitude, according to the table below.

ΔP = 5 PSI	FL	100	150	200	230
	CABIN ALTITUDE	0	3000	6000	8000

- **When starting the final descent :**

- CAB PRESS MODE SEL AUTO

COCKPIT WINDSHIELD/WINDOW ARCING

- Affected WINDOW/WINDSHIELD ANTI ICE C/B PULL
- In case of electrical arcing, pull the circuit breaker of the affected window/windshield heating system :
- . ANTI ICE L WSHLD C/B AF10
 - . ANTI ICE R WSHLD C/B AF03
 - . ANTI ICE/WINDOWS L C/B X14
 - . ANTI ICE/WINDOWS R C/B W14

VOLCANIC ASH ENCOUNTER

Accomplish the following, while making a 180° turn.

- ATC NOTIFY
- A/THR OFF
- THRUST (conditions permitting) DECREASE
- CREW OXYGEN MASKS ON/100%
- CABIN CREW NOTIFY
- PASSENGER OXYGEN AS RQRD
- ENG ANTI ICE ON
- WING ANTI ICE ON
- ECON FLOW OFF
- APU START
- ENGINE PARAMETERS MONITOR
- AIRSPEED INDICATIONS MONITOR

If airspeed is unreliable or lost, use the UNRELIABLE SPEED INDICATION/ADR CHECK PROC procedure (2.15).

Note : . If both engines flame out and speed indications are lost, use the DUAL ENGINE FAILURE procedure (1.16) to get the required pitch attitude for optimum relight speed.

. In case of engine failure, switch off the wing anti-ice before engine restart.

R
R

OVERWEIGHT LANDING

R
R

Automatic landing is certified up to MLW, but flight tests have been performed successfully up to 69 tons. In case of emergency, and under crew responsibility, an automatic landing may be performed up to 69 tons provided that the runway is approved for automatic landing.

– LDG CONF AS REQUIRED

Use the ECAM flap setting, if required for abnormal operations. In all other cases :

- FULL is preferred for optimized landing performance.
- If the aircraft weight is above the maximum weight for go-around (given in the table below), use FLAP 3 for landing.

In all cases, if landing configuration is different from FLAP FULL, use 1+F for go-around.

NOTE : For weights greater than 68000 kg (or 150 000 lb) S speed is greater than VFE CONF 2 (200 knots). Consequently the crew must select on FCU a speed below 200 knots before setting FLAPS 2. When in FLAPS 2, the crew can use managed speed again.

– LDG DIST CHECK

– PACK 1 and 2 OFF or supplied by APU

Selecting packs OFF (or supplied from APU) will increase the maximum thrust available from the engines, in the event of a go-around.

● In the final approach stages

– TARGET SPEED VLS

Reduce the selected speed on the FCU to reach VLS at runway threshold.

Touch down as smoothly as possible (Maximum V/S at touchdown 360 ft/min).

● At main landing gear touchdown

– REVERSE THRUST USE MAX AVAILABLE

● After nosewheel touchdown

– BRAKES APPLY AS NECESSARY

Maximum braking may be used after nosewheel touchdown. But, if landing distance permits, delay or reduce braking to fully benefit from the available runway length.

● Landing complete

– BRAKE FANS (◀) ON

Be prepared for tire deflation, if temperatures exceed 800° C.

MAXIMUM WEIGHT FOR GO AROUND IN CONF 3 (1000 kg)								
OAT °C	AIRPORT ELEVATION (FT)							
	0	2000	4000	6000	8000	10000	12000	14000
<10	75	74	72	71	69	65	62	58
15	75	74	72	71	69	65	62	58
20	75	74	72	71	69	65	62	56
25	75	74	72	71	69	65	59	54
30	75	74	72	71	68	62	57	
35	75	74	72	69	65			
40	75	74	72	67				
45	75	74	69					
50	75	72						
55								

COCKPIT WINDSHIELD/WINDOW CRACKED

- MAX FL 230
- CAB PRESS MODE SEL MAN
- MAN V/S CTL AS RQRD

Set the cabin altitude, according to the table below.

ΔP = 5 PSI	FL	100	150	200	230
	CABIN ALTITUDE	0	3000	6000	8000

● **When starting the final descent :**

- CAB PRESS MODE SEL AUTO

COCKPIT WINDSHIELD/WINDOW ARCING

- Affected WINDOW/WINDSHIELD ANTI ICE C/B PULL
In case of electrical arcing, pull the circuit breaker of the affected window/windshield heating system :

- . ANTI ICE L WSHLD C/B AF10 . ANTI ICE/WINDOWS L C/B X14
- . ANTI ICE R WSHLD C/B AF03 . ANTI ICE/WINDOWS R C/B W14

VOLCANIC ASH ENCOUNTER

Accomplish the following, while making a 180° turn.

- ATC NOTIFY
- A/THR OFF
- THRUST (conditions permitting) DECREASE
- CREW OXYGEN MASKS ON/100%
- CABIN CREW NOTIFY
- PASSENGER OXYGEN AS RQRD
- ENG ANTI ICE ON
- WING ANTI ICE ON
- PACK FLOW HI
- APU START
- ENGINE PARAMETERS MONITOR
- AIRSPEED INDICATIONS MONITOR

If airspeed is unreliable or lost, use the UNRELIABLE SPEED INDICATION/ADR CHECK PROC procedure (2.15).

Note : . *If both engines flame out and speed indications are lost, use the DUAL ENGINE FAILURE procedure (1.16) to get the optimum relight speed.*

. *In case of engine failure, switch off the wing anti-ice before engine restart.*

R
R

OVERWEIGHT LANDING

– LDG CONF AS REQUIRED

Use the ECAM flap setting, if required for abnormal operations. In all other cases :

- FULL is preferred for optimized landing performance.
- If the aircraft weight is above the maximum weight for go-around (given in the table below), use FLAP 3 for landing.

In all cases, if landing configuration is different from FLAP FULL, use 1+F for go-around.

NOTE : For weights greater than 70000 kg (or 154 000 lb), S speed is greater than VFE CONF 2 (200 knots). Consequently, on the FCU, the crew must select a speed below 200 knots before setting FLAPS 2. When in FLAPS 2, the crew can use managed speed again.

– LDG DIST CHECK

– PACK 1 and 2 OFF or supplied by APU

Selecting packs OFF (or supplied from APU) will increase the maximum thrust available from the engines, in the event of a go-around.

● **In the final approach stages**

– TARGET SPEED VLS

Reduce the selected speed on the FCU to reach VLS at runway threshold.
Touch down as smoothly as possible (Maximum V/S at touchdown 360 ft/min).

● **At main landing gear touchdown**

– REVERSE THRUST USE MAX AVAILABLE

● **After nosewheel touchdown**

– BRAKES APPLY AS NECESSARY

Maximum braking may be used after nosewheel touchdown. But, if landing distance permits, delay or reduce braking to fully benefit from the available runway length.

● **Landing complete**

– BRAKE FANS (◀) ON

Be prepared for tire deflation, if temperatures exceed 800° C.

MAXIMUM WEIGHT FOR GO AROUND IN CONF 3 (1000 kg)								
OAT °C	AIRPORT ELEVATION (FT)							
	0	2000	4000	6000	8000	10000	12000	14000
<10	83	81	78	74	71	66	62	58
15	83	81	78	74	71	66	62	58
20	83	81	78	74	71	66	61	56
25	83	81	78	74	70	64	59	
30	83	81	78	73	67			
35	83	81	76	70	65			
40	83	80	73	67				
45	82	76	70					
50	79	73						
55								

R
R
R
R

COCKPIT WINDSHIELD/WINDOW CRACKED

- MAX FL 230
- CAB PRESS MODE SEL MAN
- MAN V/S CTL AS RQRD

Set the cabin altitude, according to the table below.

ΔP = 5 PSI	FL	100	150	200	230
	CABIN ALTITUDE	0	3000	6000	8000

● **When starting the final descent :**

- CAB PRESS MODE SEL AUTO

COCKPIT WINDSHIELD/WINDOW ARCING

- Affected WINDOW/WINDSHIELD ANTI ICE C/B PULL
- In case of electrical arcing, pull the circuit breaker of the affected window/windshield heating system :

. ANTI ICE L WSHLD C/B AF10

. ANTI ICE/WINDOWS L C/B X14

. ANTI ICE R WSHLD C/B AF03

. ANTI ICE/WINDOWS R C/B W14

VOLCANIC ASH ENCOUNTER

Accomplish the following, while making a 180° turn.

- ATC NOTIFY
- A/THR OFF
- THRUST (conditions permitting) DECREASE
- CREW OXYGEN MASKS ON/100%
- CABIN CREW NOTIFY
- PASSENGER OXYGEN AS RQRD
- ENG ANTI ICE ON
- WING ANTI ICE ON
- PACK FLOW HI
- APU START
- ENGINE PARAMETERS MONITOR
- AIRSPEED INDICATIONS MONITOR

If airspeed is unreliable or lost, use the UNRELIABLE SPEED INDICATION/ADR CHECK PROC procedure (2.15).

Note : . If both engines flame out and speed indications are lost, use the DUAL ENGINE FAILURE procedure (1.16) to get the optimum relight speed.

. In case of engine failure, switch off the wing anti-ice before engine restart.

R
R

BOMB ON BOARD

IF POSSIBLE, LAND AND EVACUATE THE AIRCRAFT IMMEDIATELY.
If it is not possible to land and evacuate the aircraft within 30 minutes, apply the following procedures :

COCKPIT PROCEDURES

Background

To avoid the activation of an altitude-sensitive bomb, the cabin altitude should not exceed the value at which the bomb has been discovered.

To reduce the effects of the explosion, the aircraft should fly as long as possible with approximately 1 PSI differential pressure, to help the blast go outwards. 1 PSI differential pressure corresponds to a 2500 feet difference between the aircraft and the cabin altitude.

These conditions are achieved by using the manual pressure control.

Procedure

The following procedure assumes that it is initiated during climb or cruise :

- First, maintain the cabin altitude.
- While maintaining the cabin altitude, descend the aircraft to the cabin altitude + 2500 feet and maintain delta P at 1 PSI.
- During further steps of descent, maintain delta P at 1 PSI.
- For landing, reduce the differential pressure to zero, until the final approach.

If flight conditions are different, the crew should adapt the procedure, bearing in mind the above-mentioned principles (background paragraph).

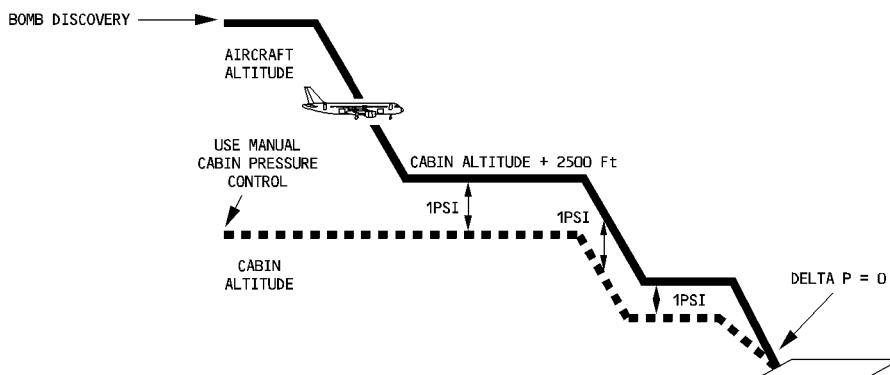

NCL5-00-0002-027-A001A



BOMB ON BOARD (Cont'd)

- AIRCRAFT (if climbing) LEVEL OFF
- CABIN PRESS MODE SEL MAN
- CAB ALT MAINTAIN
- CABIN CREW NOTIFY
- ATC/COMPANY OPERATIONS NOTIFY
- FUEL RESERVES DETERMINE

Keep in mind that when flying at cabin altitude + 2500 feet, the fuel consumption in CONF 1, with landing gear down, will be about 2.1 times that consumed in clean configuration.

- NEXT SUITABLE AIRPORT DETERMINE
- FCU SPEED SELECTION KNOB PULL AND TURN

Select the most appropriate speed, taking into account the time to destination, the fuel consumption and the fact that low speed could reduce the consequences of possible structural damage, if the bomb explodes.

- DESCENT TO CAB ALT + 2500 FEET or MEA or
minimum obstacle clearance altitude INITIATE
- AVOID SHARP MANEUVERS
- CAB ALT MAINTAIN

- **When at CAB ALT + 2500 FEET :**

- 1 PSI DELTA P MAINTAIN
 - GALLEY/COMMERCIAL (<*) OFF
 - FLAPS (fuel permitting) AT LEAST CONF 1
- For landing, use normal configuration.*
- LANDING GEAR
(fuel permitting, except for flight over water) DOWN

- **For any other steps of descent :**

- 1 PSI DELTA P MAINTAIN

- **During approach :**

- CABIN PRESS MODE SEL AUTO

- **When aircraft on ground and stopped in a remote area (if possible) :**

- EVACUATION INITIATE

Avoid exits and exiting on the same side as the bomb ; avoid exits and exiting near the bomb.



R

BOMB ON BOARD (Cont'd)**CABIN PROCEDURES**

If a suspect device is found in the cabin :

WARNING

Do not cut or disconnect any wires and do not open or attempt to gain entry to internal components of a closed or concealed suspect device. Any attempt may result in an explosion. Booby-trapped closed devices have been used on aircraft in the past.

WARNING

Alternate locations must not be used without consulting with an aviation explosives security specialist. **Never take a suspect device to the flight deck.**

CAUTION

The least risk bomb location for aircraft structure and systems is center of the RH aft cabin door.

– EOD PERSONNEL ON BOARD CHECK

Announce : "Is there any EOD personnel on board ?". By using the initials, only persons familiar with EOD (Explosive Ordnance Disposal) will be made aware of the problem.

– BOMB DO NOT OPEN, DO NOT CUT WIRES,
SECURE AGAINST SLIPPING, AVOID SHOCKS

Secure in the attitude found and do not lift before having checked for an anti-lift ignition device.

– PASSENGERS LEAD AWAY FROM BOMB

Move passengers at least 4 seat rows away the bomb location. On full flights, it may be necessary to double up passengers to achieve standoff from the suspect device.

Passengers near the bomb should protect their heads with pillows, blankets. All passengers must remain seated with seatbelts on and, if possible, head below the top of the head rest. Seat backs and tray tables must be in their full upright position.

Service items may need to be collected in order to secure tray tables.

– PORTABLE ELECTRONIC DEVICES SWITCH OFF

The cabin crews must command passengers to switch off all portable electronic devices.

– BOMB CHECK NO ANTI-LIFT DEVICE

To check for an anti-lift switch or lever, slide a string or stiff card (such as the emergency information card) under the bomb, without disturbing the bomb.

If the string or card cannot be slipped under the bomb, it may indicate that an anti-lift switch or lever is present and that the bomb cannot be moved.

If a card is used an can be slid under the bomb, leave it under the bomb and move together with the bomb.

If it is not possible to move the bomb, then it should be surrounded with a single thin sheet of plastic (e.g. trash bag), then with wetted materials, and other blast attenuation materials such as seat cushions and soft carry-on baggage. Move personnel as far away from the bomb location as possible.



BOMB ON BOARD (Cont'd)

Build up at 25 cm (10 in) of wetted material around the sides and on top of the bomb. DO NOT PLACE ANYTHING BETWEEN THE BOMB AND THE DOOR, AND MINIMIZE AIRSPACE AROUND THE BOMB.

The idea is to build up a protective surrounding of the bomb so that the explosive force is directed in the only unprotected area into the door structure.

Fill the area around the bomb with seat cushions and other soft materials such as hand luggage (saturated with water on any other nonflammable liquid) up to the cabin ceiling, compressing as much as possible. Secure the LRBL stack in place using belt, ties or other appropriate materials. The more material stacked around the bomb, the less the damage will be.

USE ONLY SOFT MATERIAL. AVOID USING MATERIALS CONTAINING ANY INFLAMMABLE LIQUID AND ANY METAL OBJECTS WHICH COULD BECOME DANGEROUS PROJECTILES.

LRBL STACK

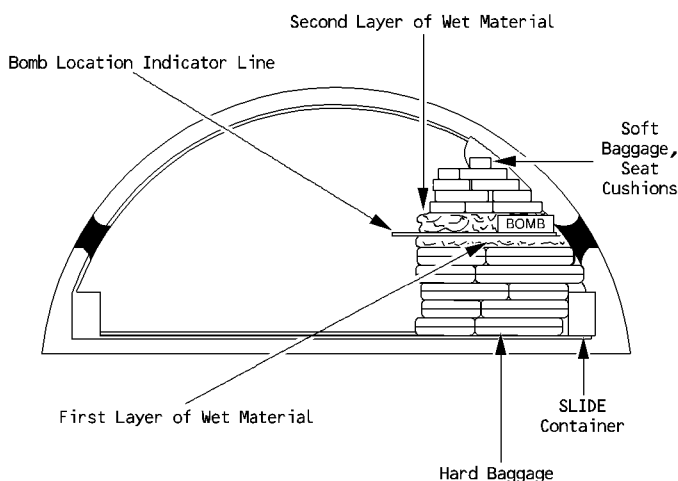

NCL5-03-0002-030A A001AA

– PASSENGERS MOVE/ADVISE

Move passengers at least 4 seat rows away from the least risk bomb location (RH aft cabin door). On full flights, it may be necessary to double up passengers to achieve standoff from the suspect device.

Passengers near the bomb should protect their heads with pillows, blankets. All passengers must remain seated with seatbelts on and, if possible, head below the top of the head rest. Seat backs and tray tables must be in their full upright position.

– CABIN CREW NOTIFY COCKPIT CREW

Cabin crew notify the flight crew that the bomb is secured at the LRBL.

– EVACUATION/DISEMBARKATION EXECUTE

Evacuate through normal and emergency exits on the opposite side of the "bomb" location. Do not use the door just opposite the "bomb".

Use all available airport facilities to disembark without delay.

VAPP DETERMINATION

● NORMAL CONFIGURATION (OR NO ΔVREF)

The FMGS performs the following VAPP computation for landing in normal configuration (CONF 3 or CONF FULL). These VAPP also apply for failure cases without ΔVREF.

Note : For CG < 25 %, add 2 knots to VLS CONF FULL and VLS CONF 3.

W(1000Kg)	40	44	48	52	56	60	64	68	72	76	78
VLS CONF FULL (KT)	106	111	116	121	125	129	134	138	142	146	147
VLS CONF 3 (KT)	109	114	119	124	128	133	137	142	146	150	152

+

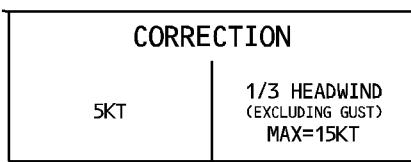

=

VAPP

$$V_{APP} = VLS + 5kt* + W_{IND} CORR$$

NCL5-00-0002-031-A130AA

The 5-knot increment is required, when the A/THR is used, or when an autoland is performed.

- NOTE :** * – In case of ice accretion, Vapp must not be lower than :
- VLS + 5 knots in CONF FULL
 - VLS + 10 knots in CONF 3
 - In case of gusty crosswind greater than 20 knots, Vapp should be at least VLS + 5 knots.

R
R
R
R
R

● ABNORMAL/EMERGENCY CONFIGURATION (WITH ΔVREF)

Note : For CG < 25 %, add 2 knots to VREF.

W(1000Kg)	40	44	48	52	56	60	64	68	72	76	78
VREF=VLS CONF FULL	106	111	116	121	125	129	134	138	142	146	147

+



+

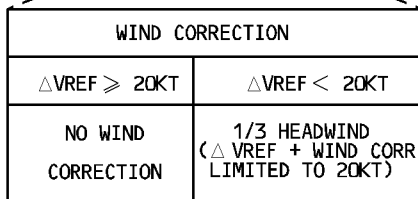

=

VAPP

$$V_{APP} = VREF + \Delta VREF + WIND CORR$$

TO BE INSERTED ON MCDU PERF APPR PAGE

NCL5-00-0002-031-B130AA

LDG CONF/APPR SPD/LDG DIST FOLLOWING FAILURES

R	A320 FAMILY	FAILURE	FLAPS LEVER POSITION FOR LDG	Δ VREF APPR SPD INCREMENT	MULTIPLY LDG DIST (CONF FULL) BY		
					DRY	WET (b)	CONTA (b)
ELEC	AC BUS 1		Norm (a)	–	1.20	1.20	1.10
	DC BUS 2		Norm (a)	–	1.25	1.35	1.25
	DC ESS BUS (if no Ice accretion)		Norm (a)	–	1.20	1.25	1.20
	DC ESS BUS (if Ice accretion)		Norm (a)	10	1.35	1.40	1.30
	DC EMER CONF		Norm (a)	–	3.05	2.55	2.25
	DC BUS 1+2 (if no Ice accretion)		Norm (a)	–	1.95	1.65	1.45
	DC BUS 1+2 (if Ice accretion)		Norm (a)	10	2.20	1.85	1.65
	EMER ELEC CONF		3	10	2.65	2.30	2.15
FTL CTL	ONE SPLR FAULT		Norm (a)	–	1.20	1.20	1.10
	TWO SPLR FAULT		Norm (a)	–	1.25	1.25	1.15
	THREE SPLR FAULT		Norm (a)	–	1.30	1.25	1.20
	ALL SPLR FAULT		Norm (a)	–	1.50	1.50	1.40
	SEC 1 or SEC 3 FAULT		Norm (a)	–	1.25	1.25	1.15
	SEC 2 FAULT		Norm (a)	–	1.20	1.20	1.10
	SEC 2+3 FAULT		Norm (a)	–	1.25	1.25	1.15
	SEC 1+3 FAULT		Norm (a)	–	1.35	1.45	1.40
	SEC 1+2 FAULT		Norm (a)	–	1.25	1.30	1.25
	SEC 1+2+3 FAULT		3	10	1.60	2.20	2.25
	ALTN LAW/DIRECT LAW/ELAC 1+2/L+R ELEV FAULT/L(R) ELEV FAULT/STAB JAM		3	10	1.35*	1.30*	1.25*
FLAPS/ SLATS	FLAPS and SLATS at zero		1	60 (APPR) 50 (THRESHOLD)	2.40*	2.10*	2.10*
	FLAPS < 1	S < 1	3	45	2.30*	2.00*	2.00*
		S ≥ 1	3	25	1.95*	1.60*	1.60*
	1 ≤ FLAPS < 2	S < 1	3	30	1.85*	1.70*	1.60*
		S ≥ 1	3	15	1.50*	1.45*	1.35*
	2 ≤ FLAPS < 3	S < 1	3	25	1.70*	1.55*	1.50*
		S ≥ 1	3	10	1.40*	1.35*	1.25*
	FLAPS = 3	S < 1	3	25	1.65*	1.55*	1.50*
		1 ≤ S ≤ 3	3	10	1.35*	1.30*	1.25*
		S > 3	3	5	1.30*	1.25*	1.20*
	FLAPS > 3	S < 1	NOT ALLOWED				
		1 ≤ S ≤ 3	FULL	10	1.30*	1.30*	1.20*
		S > 3	FULL	5	1.25*	1.25*	1.15*
HYD	GREEN		Norm (a)	–	1.30	1.35	1.30
	BLUE		Norm (a)	–	1.20	1.20	1.10
	YELLOW		Norm (a)	–	1.25	1.30	1.20
	GREEN + BLUE		3	25	1.80	2.00	1.95
	GREEN + YELLOW		3	25	2.80	2.45	2.45
	BLUE + YELLOW		Norm (a)	–	1.70	1.90	1.85

- (a) If "CONF 3" is used when "NORM" is indicated in the table, add 6 knots to the VREF and multiply the resulting landing distance by an additional factor of 1.10.
- (b) The landing distance coefficients for wet or contaminated runways assume the use of maximum reverse thrust on all of the operative reversers. Apply these coefficients to the actual landing distance with reversers.

VAPP DETERMINATION

R ● NORMAL CONFIGURATION (OR NO ΔVREF)

R The FMGS performs the following VAPP computation for landing in
 R normal configuration (CONF 3 or CONF FULL). These VAPP also
 R apply for failure cases without ΔVREF.

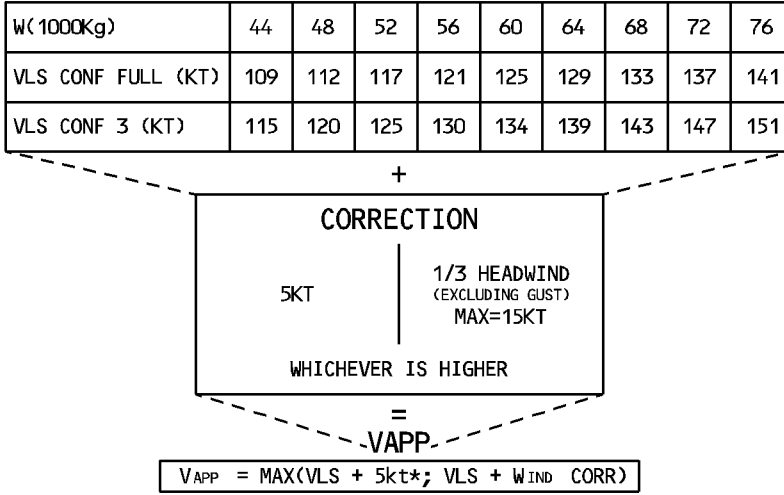

NCL5-00-0002-031-A146AA

The 5 knot increment is required when the A/THR is used, or when an autoland is performed.

NOTE : * – In case of ice accretion, Vapp must not be lower than :

- VLS + 5 knots in CONF FULL
- VLS + 10 knots in CONF 3
- In case of gusty crosswind greater than 20 knots, Vapp should be at least VLS + 5 knots.

R ● ABNORMAL/EMERGENCY CONFIGURATION (WITH ΔVREF)

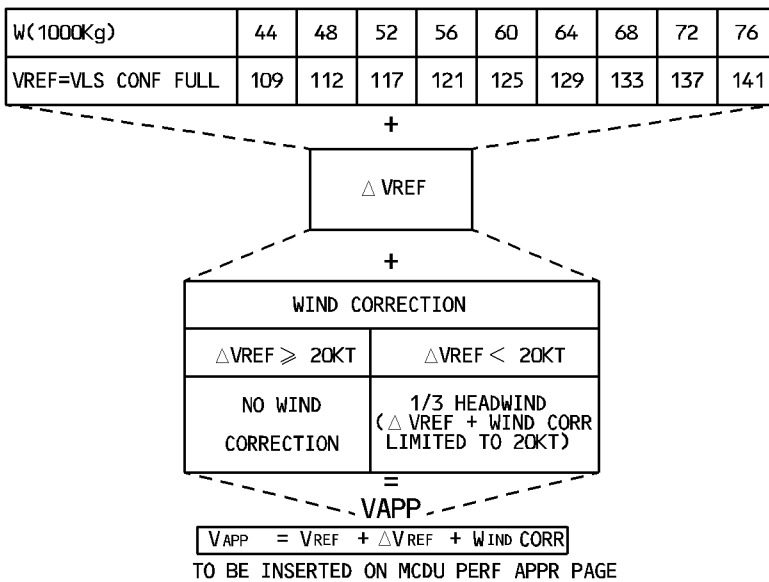

NCL5-00-0002-031-B146AA

IAE Eng. : V2527M

Mod : 20268

A319-133

LDG CONF/APPR SPD/LDG DIST FOLLOWING FAILURES

R	A320 FAMILY	FAILURE	FLAPS LEVER POSITION FOR LDG	Δ VREF APPR SPD INCREMENT	MULTIPLY LDG DIST (CONF FULL) BY		
					DRY	WET (b)	CONTA (b)
ELEC		DC BUS 2	Norm (a)	–	1.30	1.35	1.30
		DC ESS BUS (if no Ice accretion)/AC BUS 1	Norm (a)	–	1.20	1.25	1.20
		DC ESS BUS (if Ice accretion)	Norm (a)	10	1.35	1.40	1.35
		DC EMER CONF	Norm (a)	–	3.00	2.40	2.15
		DC BUS 1+2 (if no Ice accretion)	Norm (a)	–	2.05	1.65	1.50
		DC BUS 1+2 (if Ice accretion)	Norm (a)	10	2.30	1.85	1.70
		EMER ELEC CONF	3	10	2.85	2.35	2.25
FTL CTL		ONE SPLR FAULT	Norm (a)	–	1.25	1.20	1.15
		TWO SPLR FAULT	Norm (a)	–	1.30	1.25	1.20
		THREE SPLR FAULT	Norm (a)	–	1.35	1.30	1.25
		ALL SPLR FAULT	Norm (a)	–	1.50	1.50	1.40
		SEC 1 or SEC 3 FAULT	Norm (a)	–	1.30	1.25	1.20
		SEC 2 FAULT	Norm (a)	–	1.20	1.20	1.15
		SEC 2+3 FAULT	Norm (a)	–	1.30	1.30	1.20
		SEC 1+3 FAULT	Norm (a)	–	1.40	1.45	1.40
		SEC 1+2 FAULT	Norm (a)	–	1.30	1.30	1.30
		SEC 1+2+3 FAULT	3	10	1.60	2.05	2.20
		L (R) ELEV FAULT	3	15	1.45*	1.40*	1.35*
	ALTN LAW/DIRECT LAW/ELAC 1+2/L+R ELEV FAULT/STAB JAM	3	10	1.35*	1.35*	1.30*	
FLAPS/SLATS		FLAPS and SLATS at zero	1	60 (APPR) 50 (THRESHOLD)	2.20*	2.15*	2.20*
	FLAPS < 1	S < 1	3	45	2.10*	2.05*	2.10*
		S \geq 1	3	25	1.65*	1.65*	1.60*
	1 \leq FLAPS < 2	S < 1	3	30	1.70*	1.70*	1.65*
		S \geq 1	3	15	1.45*	1.45*	1.40*
	2 \leq FLAPS < 3	S < 1	3	25	1.60*	1.60*	1.55*
		S \geq 1	3	10	1.40*	1.35*	1.30*
	FLAPS = 3	S < 1	3	25	1.60*	1.60*	1.50*
		1 \leq S \leq 3	3	10	1.35*	1.35*	1.30*
		S > 3	3	5	1.30*	1.25*	1.20*
	FLAPS > 3	S < 1	NOT ALLOWED				
1 \leq S \leq 3		FULL	10	1.35*	1.30*	1.25*	
S > 3		FULL	5	1.25*	1.25*	1.15*	
HYD		GREEN	Norm (a)	–	1.35	1.35	1.30
		BLUE	Norm (a)	–	1.20	1.20	1.15
		YELLOW	Norm (a)	–	1.25	1.30	1.25
		GREEN + BLUE	3	25	1.80	2.05	2.00
		GREEN + YELLOW	3	25	2.80	2.35	2.40
		BLUE + YELLOW	Norm (a)	–	1.75	1.90	1.85

- (a) If "CONF 3" is used when "NORM" is indicated in the table, add 10 knots to the VREF and multiply the resulting landing distance by an additional factor of 1.15.
- (b) The landing distance coefficients for wet or contaminated runways assume the use of maximum reverse thrust on all of the operative reversers. Apply these coefficients to the actual landing distance with reversers.

VAPP DETERMINATION

R ● NORMAL CONFIGURATION (OR NO ΔVREF)

R The FMGS performs the following VAPP computation for landing in
R normal configuration (CONF 3 or CONF FULL). These VAPP also
R apply for failure cases without ΔVREF.

W(1000Kg)	52	56	60	64	68	72	76	80	84	88	92	94
VLS CONF FULL (KT)	116	121	125	129	133	137	141	144	148	151	155	157
VLS CONF 3 (KT)	121	125	130	134	138	142	146	150	154	157	161	163

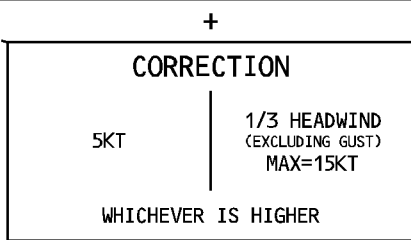

VAPP

$V_{APP} = \text{MAX}(VLS + 5kt*; VLS + \text{WIND CORR})$

NCL5-00-0002-031-A150A.A

The 5 knot increment is required when the A/THR is used, or when an autoland is performed.

NOTE : * – In case of ice accretion, Vapp must not be lower than :

- VLS + 5 knots in CONF FULL
- VLS + 10 knots in CONF 3
- In case of gusty crosswind greater than 20 knots, Vapp should be at least VLS + 5 knots.

R ● ABNORMAL/EMERGENCY CONFIGURATION (WITH ΔVREF)

W(1000Kg)	52	56	60	64	68	72	76	80	84	88	92	94
VREF=VLS CONF FULL	116	121	125	129	133	137	141	144	148	151	155	157

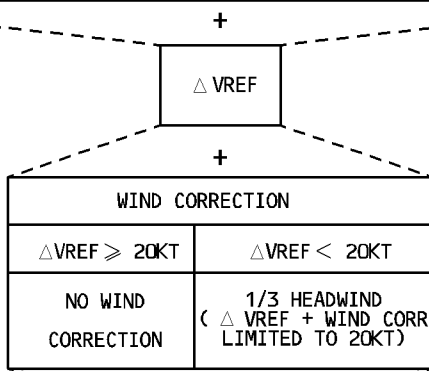

VAPP

$V_{APP} = V_{REF} + \Delta V_{REF} + \text{WIND CORR}$

TO BE INSERTED ON MCDU PERF APPR PAGE

NCL5-00-0002-031-B150A.A

IAE Eng. : V2533

Mod : 20268

A321-231

LDG CONF/APPR SPD/LDG DIST FOLLOWING FAILURES

A320 FAMILY	FAILURE	FLAPS LEVER POSITION FOR LDG	Δ VREF APPR SPD INCREMENT	MULTIPLY LDG DIST (CONF FULL) BY			
				DRY	WET (b)	CONTA (b)	
ELEC	AC BUS 1	Norm (a)	–	1.20	1.15	1.10	
	DC BUS 2	Norm (a)	–	1.30	1.30	1.30	
	DC ESS BUS (if no Ice accretion)	Norm (a)	–	1.20	1.20	1.20	
	DC ESS BUS (if Ice accretion)	Norm (a)	10	1.35	1.40	1.35	
	DC EMER CONF	Norm (a)	–	2.80	2.55	2.30	
	DC BUS 1+2 (if no Ice accretion)	Norm (a)	–	1.85	1.60	1.50	
	DC BUS 1+2 (if Ice accretion)	Norm (a)	10	2.05	1.80	1.70	
	EMER ELEC CONF	3	10	2.45	2.25	2.10	
FTL CTL	ONE SPLR FAULT	Norm (a)	–	1.25	1.20	1.15	
	TWO SPLR FAULT	Norm (a)	–	1.25	1.25	1.20	
	THREE SPLR FAULT	Norm (a)	–	1.30	1.25	1.20	
	ALL SPLR FAULT	Norm (a)	–	1.45	1.45	1.40	
	SEC 1 or SEC 3 FAULT	Norm (a)	–	1.25	1.25	1.20	
	SEC 2 FAULT	Norm (a)	–	1.20	1.15	1.10	
	SEC 2+3 FAULT	Norm (a)	–	1.30	1.25	1.20	
	SEC 1+3 FAULT	Norm (a)	–	1.40	1.45	1.45	
	SEC 1+2 FAULT	Norm (a)	–	1.25	1.30	1.30	
	SEC 1+2+3 FAULT	3	10	1.65	2.05	2.20	
	ALTN LAW/DIRECT LAW ELAC 1+2/L(R) ELEV FAULT/L+R ELEV FAULT/STAB JAM	3	10	1.35*	1.30*	1.25*	
FLAPS/SLATS	FLAPS and SLATS at zero		1	60 (APPR) 50 (THRESHOLD)	2.40*	2.05*	2.00*
	FLAPS < 1	S < 1	3	45	2.30*	1.95*	1.95*
		S ≥ 1	3	30	1.95*	1.65*	1.60*
	1 ≤ FLAPS < 2	S < 1	3	30	1.85*	1.65*	1.60*
		S ≥ 1	3	15	1.50*	1.40*	1.35*
	2 ≤ FLAPS < 3	S < 1	3	25	1.70*	1.55*	1.50*
		S ≥ 1	3	10	1.40*	1.35*	1.25*
	FLAPS = 3	S < 1	3	25	1.65*	1.55*	1.45*
		1 ≤ S ≤ 3	3	10	1.35*	1.30*	1.25*
		S > 3	3	5	1.25*	1.25*	1.15*
	FLAPS > 3	S < 1	NOT ALLOWED				
		1 ≤ S ≤ 3	FULL	10	1.30*	1.30*	1.20*
S > 3		FULL	5	1.25*	1.20*	1.15*	
HYD	GREEN	Norm (a)	–	1.35	1.35	1.35	
	BLUE	Norm (a)	–	1.20	1.15	1.10	
	YELLOW	Norm (a)	–	1.25	1.25	1.25	
	GREEN + BLUE	3	25	1.85	2.05	1.90	
	GREEN + YELLOW	3	30	2.50	2.35	2.40	
	BLUE + YELLOW	3	10	1.75	1.95	1.85	

- (a) If "CONF 3" is used when "NORM" is indicated in the table, add 6 knots to the VREF and multiply the resulting landing distance by an additional factor of 1.10.
- (b) The landing distance coefficients for wet or contaminated runways assume the use of maximum reverse thrust on all of the operative reversers. Apply these coefficients to the actual landing distance with reversers.

VAPP DETERMINATION

● **NORMAL CONFIGURATION (OR NO ΔVREF)**

The FMGS performs the following VAPP computation for landing in normal configuration (CONF 3 or CONF FULL). These VAPP also apply for failure cases without ΔVREF.

Note : For CG < 25 %, add 2 knots to VLS CONF FULL and VLS CONF 3.

W(1000Kg)	40	44	48	52	56	60	64	68	72	76	78
VLS CONF FULL (KT)	106	111	116	121	125	129	134	138	142	146	147
VLS CONF 3 (KT)	109	114	119	124	128	133	137	142	146	150	152

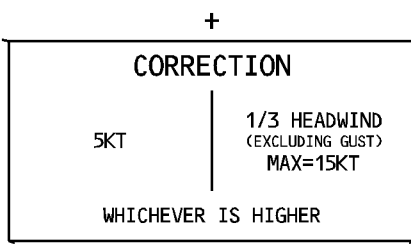

VAPP

$V_{APP} = \text{MAX}(VLS + 5KT^*; VLS + WIND CORR)$

The 5-knot increment is required when the A/THR is used, or when an autoland is performed.

- NOTE :** * – In case of ice accretion, Vapp must not be lower than :
- VLS + 5 knots in CONF FULL
 - VLS + 10 knots in CONF 3
 - In case of gusty crosswind greater than 20 knots, Vapp should be at least VLS + 5 knots.

● **ABNORMAL/EMERGENCY CONFIGURATION (WITH ΔVREF)**

Note : For CG < 25 %, add 2 knots to VREF.

W(1000Kg)	40	44	48	52	56	60	64	68	72	76	78
VREF=VLS CONF FULL	106	111	116	121	125	129	134	138	142	146	147

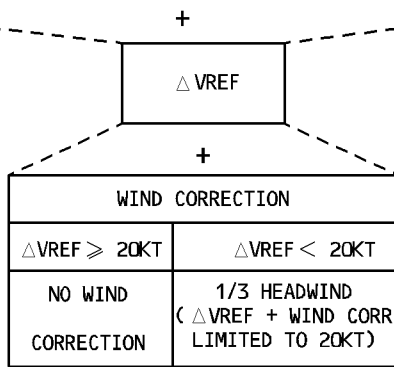

VAPP

$V_{APP} = VREF + \Delta VREF + WIND CORR$

TO BE INSERTED ON MCDU PERF APPR PAGE

NCL5-00-0002-031-A235AA

R
R
R
R
R

NCL5-00-0002-031-B235AA

IAE Eng. : V2500/V2527/V2527E

Mod : 20268 + 25225
A320-232, A320-233 + reduced VAPP function
A320-231, A320-233 + reduced VAPP function

LDG CONF/APPR SPD/LDG DIST FOLLOWING FAILURES

R	A320 FAMILY	FAILURE	FLAPS LEVER POSITION FOR LDG	Δ VREF APPR SPD INCREMENT	MULTIPLY LDG DIST (CONF FULL) BY		
					DRY	WET (b)	CONTA (b)
ELEC	AC BUS 1		Norm (a)	–	1.20	1.20	1.10
	DC BUS 2		Norm (a)	–	1.25	1.35	1.25
	DC ESS BUS (if no Ice accretion)		Norm (a)	–	1.20	1.25	1.20
	DC ESS BUS (if Ice accretion)		Norm (a)	10	1.35	1.40	1.30
	DC EMER CONF		Norm (a)	–	3.05	2.55	2.25
	DC BUS 1+2 (if no Ice accretion)		Norm (a)	–	1.95	1.65	1.45
	DC BUS 1+2 (if Ice accretion)		Norm (a)	10	2.20	1.85	1.65
	EMER ELEC CONF		3	10	2.65	2.30	2.15
FTL CTL	ONE SPLR FAULT		Norm (a)	–	1.20	1.20	1.10
	TWO SPLR FAULT		Norm (a)	–	1.25	1.25	1.15
	THREE SPLR FAULT		Norm (a)	–	1.30	1.25	1.20
	ALL SPLR FAULT		Norm (a)	–	1.50	1.50	1.40
	SEC 1 or SEC 3 FAULT		Norm (a)	–	1.25	1.25	1.15
	SEC 2 FAULT		Norm (a)	–	1.20	1.20	1.10
	SEC 2+3 FAULT		Norm (a)	–	1.25	1.25	1.15
	SEC 1+3 FAULT		Norm (a)	–	1.35	1.45	1.40
	SEC 1+2 FAULT		Norm (a)	–	1.25	1.30	1.25
	SEC 1+2+3 FAULT		3	10	1.60	2.20	2.25
	ALTN LAW/DIRECT LAW/ELAC 1+2/L+R ELEV FAULT/L(R) ELEV FAULT/STAB JAM		3	10	1.35*	1.30*	1.25*
FLAPS/SLATS	FLAPS and SLATS at zero		1	60 (APPR) 50 (THRESHOLD)	2.40*	2.10*	2.10*
	FLAPS < 1	S < 1	3	45	2.30*	2.00*	2.00*
		S ≥ 1	3	25	1.95*	1.60*	1.60*
	1 ≤ FLAPS < 2	S < 1	3	30	1.85*	1.70*	1.60*
		S ≥ 1	3	15	1.50*	1.45*	1.35*
	2 ≤ FLAPS < 3	S < 1	3	25	1.70*	1.55*	1.50*
		S ≥ 1	3	10	1.40*	1.35*	1.25*
	FLAPS = 3	S < 1	3	25	1.65*	1.55*	1.50*
		1 ≤ S ≤ 3	3	10	1.35*	1.30*	1.25*
		S > 3	3	5	1.30*	1.25*	1.20*
	FLAPS > 3	S < 1	NOT ALLOWED				
		1 ≤ S ≤ 3	FULL	10	1.30*	1.30*	1.20*
S > 3		FULL	5	1.25*	1.25*	1.15*	
HYD	GREEN		Norm (a)	–	1.30	1.35	1.30
	BLUE		Norm (a)	–	1.20	1.20	1.10
	YELLOW		Norm (a)	–	1.25	1.30	1.20
	GREEN + BLUE		3	25	1.80	2.00	1.95
	GREEN + YELLOW		3	25	2.80	2.45	2.45
	BLUE + YELLOW		Norm (a)	–	1.70	1.90	1.85

- (a) If "CONF 3" is used when "NORM" is indicated in the table, add 6 knots to the VREF and multiply the resulting landing distance by an additional factor of 1.10.
- (b) The landing distance coefficients for wet or contaminated runways assume the use of maximum reverse thrust on all of the operative reversers. Apply these coefficients to the actual landing distance with reversers.

A320 FAMILY	FAILURE	FLAPS LEVER POSITION FOR LDG	Δ VREF APPR SPD INCREMENT	MULTIPLY LDG DIST (CONF FULL) BY		
				DRY	WET (b)	CONTA (b)
BRK	ANTI SKID	Norm (a)	–	1.75	1.30	1.10
	AUTO BRK FAULT	Norm (a)	–	1.40	1.25	1.20
NAV	IR 1+2+3 FAULT	3	10	2.60	2.10	1.70
	DUAL IR FAULT/DUAL ADR FAULT ADR 1+2+3 FAULT	3	10	1.35*	1.30*	1.25*
BLEED	WING ANTI ICE NOT AVAIL (if Ice Accretion)	Norm (a)	10	1.30	1.30	1.20
ENG	REV UNLOCK with buffet	1**	55 (APPR) 40 (THRESHOLD)	2.15*	2.05*	2.05*
	REV UNLOCK with buffet	3**	10	1.35*	1.40*	1.35*

(a) If “CONF 3” is used when “NORM” is indicated in the table, add 6 knots to the VREF and multiply the resulting landing distance by an additional factor of 1.10.

(b) The landing distance coefficients for wet or contaminated runways assume the use of maximum reverse thrust on all of the operative reversers. Apply these coefficients to the actual landing distance with reversers.

* See below for multiple failures

** The applicable landing configuration (CONF 1 or CONF 3) is displayed on the ECAM STATUS page.

A320 FAMILY	FAILURE	FLAPS LEVER POSITION FOR LDG	Δ VREF APPR SPD INCREMENT	MULTIPLY LDG DIST (CONF FULL) BY		
				DRY	WET (b)	CONTA (b)
BRK	ANTI SKID	Norm (a)	–	1.75	1.30	1.10
	BRK RELEASED	Norm (a)	–	1.40	1.25	1.20
	ALTN L(R) RELEASED (IF NORM BRK FAULT)	Norm (a)	–	2.35	1.85	1.90
	ALTN L(R) RELEASED (if G SYS LO PR)	Norm (a)	–	2.50	2.25	2.75
	NORM BRK FAULT	Norm (a)	–	1.25	1.20	1.15
	NORM + ALTN BRK FAULT	Norm (a)	–	1.75	1.30	1.10
NAV	IR 1+2+3 FAULT	3	10	2.60	2.10	1.70
	DUAL IR FAULT/DUAL ADR FAULT ADR 1+2+3 FAULT	3	10	1.35*	1.30*	1.25*
BLEED	WING ANTI ICE NOT AVAIL (if Ice Accretion)	Norm (a)	10	1.30	1.30	1.20
ENG	REV UNLOCK with buffet	1**	55 (APPR) 40 (THRESHOLD)	2.15*	2.05*	2.05*
	REV UNLOCK with buffet	3**	10	1.35*	1.40*	1.35*

- (a) If “CONF 3” is used when “NORM” is indicated in the table, add 6 knots to the VREF and multiply the resulting landing distance by an additional factor of 1.10.
- (b) The landing distance coefficients for wet or contaminated runways assume the use of maximum reverse thrust on all of the operative reversers. Apply these coefficients to the actual landing distance with reversers.

* See below for multiple failures

** The applicable landing configuration (CONF 1 or CONF 3) is displayed on the ECAM STATUS page.

A320 FAMILY	FAILURE	FLAPS LEVER POSITION FOR LDG	Δ VREF APPR SPD INCREMENT	MULTIPLY LDG DIST (CONF FULL) BY		
				DRY	WET (b)	CONTA (b)
BRK	ANTI SKID	Norm (a)	–	1.60	1.30	1.10
	AUTO BRK FAULT	Norm (a)	–	1.45	1.25	1.20
NAV	IR 1+2+3 FAULT	3	10	2.45	2.00	1.55
	DUAL IR FAULT/DUAL ADR FAULT ADR 1+2+3 FAULT	3	10	1.35*	1.30*	1.25*
BLEED	WING ANTI ICE NOT AVAIL (if Ice accretion)	Norm (a)	10	1.30	1.30	1.20
ENG	REV UNLOCK with buffet	1**	55 (APPR) 40 (THRESHOLD)	2.15*	1.95*	1.95*
	REV UNLOCK with buffet	3**	10	1.35*	1.35*	1.35*

(a) If “CONF 3” is used when “NORM” is indicated in the table, add 6 knots to the VREF and multiply the resulting landing distance by an additional factor of 1.10.

(b) The landing distance coefficients for wet or contaminated runways assume the use of maximum reverse thrust on all of the operative reversers. Apply these coefficients to the actual landing distance with reversers.

** See below for multiple failures

** The applicable landing configuration (CONF 1 or CONF 3) is displayed on the ECAM STATUS page.

A320 A/C FAMILY	FAILURE	FLAPS LEVER POSITION FOR LDG	△ VREF APPR SPD INCREMENT	MULTIPLY LDG DIST (CONF FULL) BY		
				DRY	WET (b)	CONTA (b)
BRK	ANTI SKID	Norm (a)	–	1.80	1.30	1.15
	AUTO BRK FAULT	Norm (a)	–	1.40	1.30	1.25
NAV	IR 1+2+3 FAULT	3	10	2.55	1.95	1.55
	DUAL IR FAULT/DUAL ADR FAULT ADR 1+2+3 FAULT	3	10	1.35*	1.35*	1.30*
BLEED	WING ANTI ICE NOT AVAIL (if Ice Accretion)	Norm (a)	10	1.35	1.30	1.25
ENG	REV UNLOCK with buffet	1**	55 (APPR) 40 (THRESHOLD)	1.90*	2.05*	2.10*
	REV UNLOCK with buffet	3**	10	1.35*	1.40*	1.40*

(a) If “CONF 3” is used when “NORM” is indicated in the table, add 10 knots to the VREF and multiply the resulting landing distance by an additional factor of 1.15.

(b) The landing distance coefficients for wet or contaminated runways assume the use of maximum reverse thrust on all of the operative reversers. Apply these coefficients to the actual landing distance with reversers.

* See below for multiple failures

** The applicable landing configuration (CONF 1 or CONF 3) is displayed on the ECAM STATUS page.

R USE OF THE TABLE (PREVIOUS PAGES)

R – Δ VREF values take into account the necessary corrections, due to failures and the required landing configuration. The Δ VREF values are rounded off to take into account all possible weight ranges.

R LDG DIST factors must be applied to the actual "LANDING DISTANCE WITHOUT AUTOBRAKE-CONFIGURATION FULL" (Refer to QRH 4.03).

R – For a single failure :

R . Determine the LDG CONF to be selected

R . Determine the Δ VREF

R . $VAPP = VREF + \Delta VREF + WIND CORRECTION$ (Refer to QRH 2.31).

R . Determine the LDG DIST factor.

R – For multiple failures :

R . Only combine PRIMARY or SINGLE failures. In the case of a PRIMARY failure, the associated effects of SECONDARY(s) failure are taken into account by the Δ VREF and LDG DIST factor computation.

R . Use the lowest LDG CONF

R . Use the highest Δ VREF to compute the VAPP.

R . Multiply the applicable LDG DIST factors together, unless all values are marked with an asterisk (*). If all values are marked with an asterisk, use the highest LDG DIST factor.

R . Examples Applicable to Dry Runways :

FLAPS FAULT (F < 3, S \geq 1)	LDG CONF 3	Δ VREF = 10 KT	LDG DIST \times 1.40*
BRK ANTI SKID	NORM CONF	Δ VREF = 0	LDG DIST \times 1.75
TOTAL	LDG CONF 3	Δ VREF = 10 KT	LDG DIST \times 2.45

R VREF = 131 KT \rightarrow VAPP = 131 + 10 + WIND (10 KT MAX)

R = 141 KT + WIND (10 KT MAX)

ALTN LAW	LDG CONF 3	Δ VREF = 10 KT	LDG DIST \times 1.35*
FLAPS FAULT (F < 1, S \geq 1)	LDG CONF 3	Δ VREF = 25 KT	LDG DIST \times 1.95*
TOTAL	LDG CONF 3	Δ VREF = 25 KT	LDG DIST \times 1.95

R VREF = 140 KT \rightarrow VAPP = 140 + 25 + 0 (No wind correction)

R = 165 KT

TRIPPED C/B REENGAGEMENT

R In flight, do not reengage a circuit breaker (C/B) that has tripped by itself,
 R unless the Captain judges it necessary to do so for the safe continuation
 R of the flight. This procedure should be adopted only as a last resort, and
 R only one reengagement should be attempted.

R On ground, do not reengage the C/B of the fuel pump(s) of any tank. For
 R all other C/Bs, if the flight crew coordinates the action with maintenance,
 R the flight crew may reengage a tripped C/B, provided that the cause of
 R the tripped C/B is identified.

COMPUTER RESET

When a digital computer behaves abnormally, as a result of an electrical transient, for example, the Operator can stop the abnormal behavior by briefly interrupting the power supply to its processor.

The flight crew can reset most of the computers in this aircraft with a normal cockpit control (selector or pushbutton). However, for some systems, the only way to cut off electrical power is to pull the associated circuit breaker.

PROCEDURE

To perform a computer reset :

- Select the related normal cockpit control OFF, or pull the corresponding reset pushbutton or circuit breaker
- Wait 3 seconds if a normal cockpit control is used, or 5 seconds if a circuit breaker is used (unless a different time is indicated)
- Select the related normal cockpit control ON, or push the corresponding reset pushbutton or circuit breaker
- Wait 3 seconds for the end of the reset.

WARNING

Do not reset more than one computer at the same time, unless instructed to do so.

NOTE : Due to the many customization possibilities of the C/B panel :

Before taking any action on the C/B panel, the flight crew must crosscheck that the C/B label corresponds to the affected system.

R USE OF THE TABLE (PREVIOUS PAGES)

R – Δ VREF values take into account the necessary corrections, due to failures and the required landing configuration. The Δ VREF values are rounded off to take into account all possible weight ranges.

R LDG DIST factors must be applied to the actual "LANDING DISTANCE WITHOUT AUTOBRAKE-CONFIGURATION FULL" (Refer to QRH 4.03).

R – For a single failure :

R . Determine the LDG CONF to be selected

R . Determine the Δ VREF

R . $VAPP = VREF + \Delta VREF + WIND CORRECTION$ (Refer to QRH 2.31).

R . Determine the LDG DIST factor.

R – For multiple failures :

R . Only combine PRIMARY or SINGLE failures. In the case of a PRIMARY failure, the associated effects of SECONDARY(s) failure are taken into account by the Δ VREF and LDG DIST factor computation.

R . Use the lowest LDG CONF

R . Use the highest Δ VREF to compute the VAPP.

R . Multiply the applicable LDG DIST factors together, unless all values are marked with an asterisk (*). If all values are marked with an asterisk, use the highest LDG DIST factor.

R . Examples Applicable to Dry Runways :

FLAPS FAULT (F < 3, S \geq 1)	LDG CONF 3	Δ VREF = 10 KT	LDG DIST \times 1.40*
BRK ANTI SKID	NORM CONF	Δ VREF = 0	LDG DIST \times 1.60
TOTAL	LDG CONF 3	Δ VREF = 10 KT	LDG DIST \times 2.24

R VREF = 131 KT \rightarrow VAPP = 131 + 10 + WIND (10 KT MAX)

R = 141 KT + WIND (10 KT MAX)

ALTN LAW	LDG CONF 3	Δ VREF = 10 KT	LDG DIST \times 1.35*
FLAPS FAULT (F < 1, S \geq 1)	LDG CONF 3	Δ VREF = 30 KT	LDG DIST \times 1.95*
TOTAL	LDG CONF 3	Δ VREF = 30 KT	LDG DIST \times 1.95*

R VREF = 140 KT \rightarrow VAPP = 140 + 30 + 0 (No wind correction)

R = 170 KT

TRIPPED C/B REENGAGEMENT

R In flight, do not reengage a circuit breaker (C/B) that has tripped by itself,
 R unless the Captain judges it necessary to do so for the safe continuation
 R of the flight. This procedure should be adopted only as a last resort, and
 R only one reengagement should be attempted.

R On ground, do not reengage the C/B of the fuel pump(s) of any tank. For
 R all other C/Bs, if the flight crew coordinates the action with maintenance,
 R the flight crew may reengage a tripped C/B, provided that the cause of
 R the tripped C/B is identified.

COMPUTER RESET

When a digital computer behaves abnormally, as a result of an electrical transient, for example, the Operator can stop the abnormal behavior by briefly interrupting the power supply to its processor.

The flight crew can reset most of the computers in this aircraft with a normal cockpit control (selector or pushbutton). However, for some systems, the only way to cut off electrical power is to pull the associated circuit breaker.

PROCEDURE

To perform a computer reset :

- Select the related normal cockpit control OFF, or pull the corresponding reset pushbutton or circuit breaker
- Wait 3 seconds if a normal cockpit control is used, or 5 seconds if a circuit breaker is used (unless a different time is indicated)
- Select the related normal cockpit control ON, or push the corresponding reset pushbutton or circuit breaker
- Wait 3 seconds for the end of the reset.

WARNING

Do not reset more than one computer at the same time, unless instructed to do so.

NOTE : Due to the many customization possibilities of the C/B panel :

Before taking any action on the C/B panel, the flight crew must crosscheck that the C/B label corresponds to the affected system.

R USE OF THE TABLE (PREVIOUS PAGES)

R – Δ VREF values take into account the necessary corrections, due to failures and the required landing configuration. The Δ VREF values are rounded off to take into account all possible weight ranges.

R LDG DIST factors must be applied to the actual "LANDING DISTANCE WITHOUT AUTOBRAKE-CONFIGURATION FULL" (Refer to QRH 4.03).

R – For a single failure :

R . Determine the LDG CONF to be selected

R . Determine the Δ VREF

R . $VAPP = VREF + \Delta VREF + WIND CORRECTION$ (Refer to QRH 2.31).

R . Determine the LDG DIST factor.

R – For multiple failures :

R . Only combine PRIMARY or SINGLE failures. In the case of a PRIMARY failure, the associated effects of SECONDARY(s) failure are taken into account by the Δ VREF and LDG DIST factor computation.

R . Use the lowest LDG CONF

R . Use the highest Δ VREF to compute the VAPP.

R . Multiply the applicable LDG DIST factors together, unless all values are marked with an asterisk (*). If all values are marked with an asterisk, use the highest LDG DIST factor.

R . Examples Applicable to Dry Runways :

FLAPS FAULT (F < 3, S ≥ 1)	LDG CONF 3	Δ VREF = 10 KT	LDG DIST × 1.40*
BRK ANTI SKID	NORM CONF	Δ VREF = 0	LDG DIST × 1.80
TOTAL	LDG CONF 3	Δ VREF = 10 KT	LDG DIST × 2.52

R $VREF = 131 \text{ KT} \rightarrow VAPP = 131 + 10 + WIND (10 \text{ KT MAX})$

R $= 141 \text{ KT} + WIND (10 \text{ KT MAX})$

ALTN LAW	LDG CONF 3	Δ VREF = 10 KT	LDG DIST × 1.35*
FLAPS FAULT (F < 1, S ≥ 1)	LDG CONF 3	Δ VREF = 25 KT	LDG DIST × 1.65*
TOTAL	LDG CONF 3	Δ VREF = 25 KT	LDG DIST × 1.65

R $VREF = 140 \text{ KT} \rightarrow VAPP = 140 + 25 + 0$ (No wind correction)

R $= 165 \text{ KT}$

TRIPPED C/B REENGAGEMENT

R In flight, do not reengage a circuit breaker (C/B) that has tripped by itself,
 R unless the Captain judges it necessary to do so for the safe continuation
 R of the flight. This procedure should be adopted only as a last resort, and
 R only one reengagement should be attempted.

R On ground, do not reengage the C/B of the fuel pump(s) of any tank. For
 R all other C/Bs, if the flight crew coordinates the action with maintenance,
 R the flight crew may reengage a tripped C/B, provided that the cause of
 R the tripped C/B is identified.

COMPUTER RESET

When a digital computer behaves abnormally, as a result of an electrical transient, for example, the Operator can stop the abnormal behavior by briefly interrupting the power supply to its processor.

The flight crew can reset most of the computers in this aircraft with a normal cockpit control (selector or pushbutton). However, for some systems, the only way to cut off electrical power is to pull the associated circuit breaker.

PROCEDURE

To perform a computer reset :

- Select the related normal cockpit control OFF, or pull the corresponding reset pushbutton or circuit breaker
- Wait 3 seconds if a normal cockpit control is used, or 5 seconds if a circuit breaker is used (unless a different time is indicated)
- Select the related normal cockpit control ON, or push the corresponding reset pushbutton or circuit breaker
- Wait 3 seconds for the end of the reset.

WARNING

Do not reset more than one computer at the same time, unless instructed to do so.

NOTE : Due to the many customization possibilities of the C/B panel :

Before taking any action on the C/B panel, the flight crew must crosscheck that the C/B label corresponds to the affected system.

COMPUTER RESET TABLE

The computers most prone to reset are listed in the table below, along with the associated reset procedure or FCOM reference, when applicable.

Specific reset procedures included in OEB or Temporary revisions are not referenced in this table and, when issued, supercede this table.

– On ground, almost all computers can be reset and are not limited to the ones indicated in the table.

The following computers are not allowed to be reset in specific circumstances :

- . ECU (Engine Control Unit on CFM engines), or EEC (Electronic Engine Control on IAE engines), and EIU (Engine Interface Unit) while the engine is running.
- . BSCU (Brake Steering Control Unit), if the aircraft is not stopped. (Refer to 3.04.32).

– In flight, as a general rule, the crew must restrict computer resets to those listed in the table, or to those in applicable TRs or OEBs. Before taking any action on other computes, the flight crew must consider and fully understand the consequences.

CAUTION

Do not pull the following circuit breakers :

- SFCC (could lead to SLATS/FLAPS locked).
- ECU or EEC, EIU.

Also refer to the FCOM 3.04.24.

NOTE: In the table's "reset" column, the "if applicable" note signifies that, depending on the computer standard, the reset procedure may no longer be necessary. If this is the case, the reset procedure is removed from the applicable FCOM section.

ATA	System malfunction or ECAM Warning/Caution	Affected system	Reset
21	VENT AVNCS SYS FAULT	AEVC	<p><u>On ground only :</u></p> <ul style="list-style-type: none"> - Pull C/B Y 17 on 122VU. - Wait 1 second before pushing the C/B.
22	AUTO FLT FCU 1(2) FAULT	FCU	<p><u>In flight :</u></p> <ul style="list-style-type: none"> - Pull the C/B B05 on 49VU for FCU1, or M21 on 121VU for FCU2. - Push it after 5 seconds. - CHECK the displayed targets and the barometer reference, and correct them if necessary. <p><u>On ground :</u></p> <ul style="list-style-type: none"> - Pull the C/B B05 on 49VU for FCU1, or M21 on 121VU for FCU2. - Push it after 5 seconds. - If FCU1(2) FAULT disappears, CHECK the displayed targets and barometer reference, and correct them if necessary (RESET successful) - If FCU1(2) FAULT remains, pull both C/B B05 on 49VU and M21 on 121VU - Push them after 7 minutes, with a delay of less than 5 seconds between side 1 and 2 - Wait at least 30 seconds for FCU1 and FCU2 safety tests completion - CHECK the displayed targets and barometer reference, and correct them if necessary (RESET successful)
	AUTO FLT FCU 1+2 FAULT	FCU	<p><u>In flight :</u></p> <ul style="list-style-type: none"> - Pull the C/B B05 on 49VU for FCU1, and then M21 on 121VU for FCU2. - Push them after 5 seconds. - CHECK the displayed targets and the barometer reference, and correct them if necessary. <p><u>On ground :</u></p> <ul style="list-style-type: none"> - Pull the C/B B05 on 49VU for FCU1, and then M21 on 121VU for FCU2. - Push them after 5 seconds. - If FCU 1 + 2 FAULT disappears, CHECK the displayed targets and barometer reference, and correct them if necessary (RESET successful) - If FCU 1 + 2 FAULT remains, pull again both C/B B05 on 49VU and M21 on 121VU - Push them after 7 minutes, with a delay of less than 5 seconds between side 1 and 2 - Wait for at least 30 seconds for FCU1 and FCU2 safety tests completion - CHECK the displayed targets and barometer reference, and correct them if necessary (RESET successful) <p>FCU targets are synchronized on current aircraft values, and displayed as selected targets.</p> <ul style="list-style-type: none"> - RE-ENTER the barometer altimeter setting value, if necessary.

R

R
R
RR
R
R

ATA	System Malfunction or ECAM Warning/Caution	Affected System	Reset
R R R R R R R R R	AUTO FLT YAW DAMPER 1(2) FAULT	FAC 1(2)	Refer to the FCOM 3.02.22, if applicable.
	WINDSHEAR DET FAULT or REAC W/S DET FAULT (◀)	FAC 1 + 2	
	One MCDU locked, or blank Both MCDU locked, or blank FMGC malfunction	MCDU FMGC FMGC	Refer to the FCOM 4.06.20
R R R R R R R R R	COM CIDS 1+2 FAULT	CIDS	<u>On ground, or in flight :</u> <ul style="list-style-type: none"> – Pull the C/Bs in the following order : G02 on 49VU, M05 on 121VU. – Wait 10 seconds, then – Push the C/Bs in the following order : M05, G02. – After CIDS reset, wait approximately 4 minutes, before recovering normal operation.
	Uncommanded EVAC horn activation	CIDS	<u>On ground, or in flight :</u> Press the EVAC HORN SHUT OFF pushbutton. . IF UNSUCCESSFUL : <ul style="list-style-type: none"> – Pull the C/Bs in the following order : G02 on 49VU, M05 on 121VU. – Wait 10 seconds, then : – Push the C/Bs in the following order : M05, G02. – After CIDS reset, wait approximately 4 minutes, before recovering normal operation.
	Frozen RMP	RMP	Refer to the FCOM 3.04.23.
	FAP freezing	FAP or Tape reproducer PRAM	<u>On ground, or in flight :</u> <ul style="list-style-type: none"> – Pull C/B M14 (or Q14 ◀) of the FAP in the 121VU. – Wait 10 seconds before pushing the C/B. . IF UNSUCCESSFUL : – Pull the tape reproducer/PRAM C/B F07 on 2000 VU (cabin). – Wait 10 seconds, before pushing the C/B.

ATA	System malfunction or ECAM Warning/Caution	Affected system	Reset
26	SMOKE LAV + CRG DET FAULT	SDCU	On ground only : – Pull C/B C06 on 49VU, and C/B T18 on 122VU. – Wait 10 seconds before pushing both C/Bs.
27	F/CTL ELAC 1(2) FAULT F/CTL ALTN LAW F/CTL ELAC 1(2) PITCH FAULT	ELAC	– Refer to the FCOM 3.02.27, if applicable.
	ELAC or SEC malfunction	ELAC or SEC	WARNING : Do not reset more than one computer at a time. It is possible to reset the flight control computers in flight, even if not requested by the ECAM, provided only one reset is performed at a time : For the ELAC only, in case of uncommanded maneuvers during the flight, the reset is not recommended. <i>Note : When an ELAC reset is performed on ground, the crew must check the pitch trim position.</i>
R 28	Loss of fuel quantity indication	FQIC	On ground, or in flight : – Pull the C/B of the affected channel : . Channel 1 A13 on 49VU . Channel 2 M27 on 121VU – Wait 5 seconds, before pushing the C/B. <i>Note : The fuel quantity indication will be re-established within one minute.</i>

ATA	System Malfunction or ECAM Warning/Caution	Affected System	Reset
R R R R R R R R	AUTO FLT YAW DAMPER 1(2) FAULT	FAC 1(2)	Refer to the FCOM 3.02.22, if applicable.
	WINDSHEAR DET FAULT or REAC W/S DET FAULT (◀)	FAC 1 + 2	
	One MCDU locked, or blank Both MCDU locked, or blank FMGC malfunction	MCDU FMGC FMGC	Refer to the FCOM 4.06.20
R R R	COM CIDS 1+2 FAULT	CIDS	On ground, or in flight : – Pull the C/Bs in the following order : G01 on 49VU, M06 on 121VU, G02 on 49VU, M07 on 121VU. – Wait 10 seconds, then – Push the C/Bs in the following order : M06, M07, G01, G02. – After CIDS reset, wait approximately 4 minutes, before recovering normal operation.
	Uncommanded EVAC horn activation	CIDS	On ground, or in flight : Press the EVAC HORN SHUT OFF pushbutton. . IF UNSUCCESSFUL : – Pull the C/Bs in the following order : G01 on 49VU, M06 on 121VU, G02 on 49VU, M07 on 121VU. – Wait 10 seconds, then – Push the C/Bs in the following order : M06, M07, G01, G02. – After CIDS reset, wait approximately 4 minutes, before recovering normal operation.
R R R	Frozen RMP	RMP	Refer to FCOM 3.04.23.
	FAP freezing	FAP or Tape reproducer PRAM	On ground, or in flight : – Pull C/B M14 (or Q14 ◀) of the FAP in the 121VU. – Wait 10 seconds before pushing the C/B. . IF UNSUCCESSFUL : – Pull the tape reproducer/PRAM C/B F07 on 2000 VU (cabin). – Wait 10 seconds, before pushing the C/B.
R			

ATA	System malfunction or ECAM Warning/Caution	Affected system	Reset
26	SMOKE LAV + CRG DET FAULT	SDCU	On ground only : – Pull C/B C06 on 49VU, and C/B T18 on 122VU. – Wait 10 seconds before pushing both C/Bs.
27	F/CTL ELAC 1(2) FAULT F/CTL ALTN LAW F/CTL ELAC 1(2) PITCH FAULT	ELAC	– Refer to the FCOM 3.02.27, if applicable.
	ELAC or SEC malfunction	ELAC or SEC	WARNING : Do not reset more than one computer at a time. It is possible to reset the flight control computers in flight, even if not requested by the ECAM, provided only one reset is performed at a time : For the ELAC only, in case of uncommanded maneuvers during the flight, the reset is not recommended. <i>Note : When an ELAC reset is performed on ground, the crew must check the pitch trim position.</i>
R 28	Loss of fuel quantity indication	FQIC	On ground, or in flight : – Pull the C/B of the affected channel : . Channel 1 A13 on 49VU . Channel 2 M27 on 121VU – Wait 5 seconds, before pushing the C/B. <i>Note : The fuel quantity indication will be re-established within one minute.</i>

ATA	System Malfunction or ECAM Warning/Caution	Affected System	Reset
22	AUTO FLT YAW DAMPER 1(2) FAULT	FAC 1(2)	Refer to the FCOM 3.02.22, if applicable.
	WINDSHEAR DET FAULT or REAC W/S DET FAULT (⚠)	FAC 1 + 2	
	One MCDU locked, or blank Both MCDU locked, or blank FMGC malfunction	MCDU FMGC FMGC	Refer to the FCOM 4.06.20
23	COM CIDS 1+2 FAULT	CIDS	<p>On ground, or in flight :</p> <ul style="list-style-type: none"> - Pull the C/Bs in the following order : G01 on 49VU, M05 on 121VU, G02 on 49VU, M06 on 121VU. - Wait 10 seconds, then - Push the C/Bs in the following order : M05, M06, G01, G02. - After CIDS reset, wait approximately 4 minutes, before recovering normal operation.
	Uncommanded EVAC horn activation	CIDS	<p>On ground, or in flight :</p> <p>Press the EVAC SHUT OFF pushbutton . IF UNSUCCESSFUL :</p> <ul style="list-style-type: none"> - Pull the C/Bs in the following order : G01 on 49VU, M05 on 121VU, G02 on 49VU, M06 on 121VU. - Wait 10 seconds, then : - Push the C/Bs in the following order : M05, M06, G01, G02. - After CIDS reset, wait approximately 4 minutes, before recovering normal operation.
	Frozen RMP	RMP	Refer to the FCOM 3.04.23.
	FAP freezing	FAP or Tape reproducer PRAM	<p>On ground, or in flight :</p> <ul style="list-style-type: none"> - Pull C/B M14 (or Q14 ⚠) of the FAP in the 121VU. - Wait 10 seconds before pushing the C/B. . IF UNSUCCESSFUL : - Pull the tape reproducer/PRAM C/B F07 on 2000 VU (cabin). - Wait 10 seconds, before pushing the C/B.

ATA	System malfunction or ECAM Warning/Caution	Affected system	Reset
26	SMOKE LAV + CRG DET FAULT	SDCU	On ground only : – Pull C/B C06 on 49VU, and C/B T18 on 122VU. – Wait 10 seconds before pushing both C/Bs.
27	F/CTL ELAC 1(2) FAULT F/CTL ALTN LAW F/CTL ELAC 1(2) PITCH FAULT	ELAC	– Refer to the FCOM 3.02.27, if applicable.
	ELAC or SEC malfunction	ELAC or SEC	WARNING : Do not reset more than one computer at a time. It is possible to reset the flight control computers in flight, even if not requested by the ECAM, provided only one reset is performed at a time : For the ELAC only, in case of uncommanded maneuvers during the flight, the reset is not recommended. <i>Note : When an ELAC reset is performed on ground, the crew must check the pitch trim position.</i>
R 28	Loss of fuel quantity indication	FQIC	On ground, or in flight : – Pull the C/B of the affected channel : . Channel 1 A13 on 49VU . Channel 2 M27 on 121VU – Wait 5 seconds, before pushing the C/B. <i>Note : The fuel quantity indication will be re-established within one minute.</i>

ATA	System Malfunction or ECAM Warning/Caution	Affected System	Reset
22	AUTO FLT YAW DAMPER 1(2) FAULT	FAC 1(2)	Refer to the FCOM 3.02.22, if applicable.
	WINDSHEAR DET FAULT or REAC W/S DET FAULT (◀)	FAC 1 + 2	
	One MCDU locked, or blank Both MCDU locked, or blank FMGC malfunction	MCDU FMGC FMGC	Refer to the FCOM 4.06.20
23	COM CIDS 1+2 FAULT	CIDS	<p>On ground, or in flight :</p> <ul style="list-style-type: none"> - Pull the C/Bs in the following order : P13 ◀ and P14 ◀ on 121VU M05 and M06 on 121VU, G01 and G02 on 49VU. - Wait 10 seconds, then : - Push the C/Bs in the following order : G01, G02, M05, M06. P13 ◀, P14 ◀ - After CIDS reset, wait approximately 4 minutes, before recovering normal operation.
	Uncommanded EVAC horn actuation	CIDS	<p>On ground, or in flight :</p> <p>Press the EVAC HORN SHUT OFF pushbutton. . IF UNSUCCESSFUL :</p> <ul style="list-style-type: none"> - Pull the C/Bs in the following order : M05 and M06 on 121VU, G01 and G02 on 49VU. - Wait 10 seconds, then : - Push the C/Bs in the following order : G01, G02, M05, M06. - After CIDS reset, wait approximately 4 minutes, before recovering normal operation.
	Frozen RMP	RMP	Refer to FCOM 3.04.23.
	FAP freezing	FAP	<p>On ground, or in flight :</p> <ul style="list-style-type: none"> - Pull the C/Bs in the following order : H01 on 49VU, Q14 on 121VU. - Wait 10 seconds, then : - Push the C/Bs in the following order : Q14, H01.

R
R

R

R
R

R

ATA	System malfunction or ECAM Warning/Caution	Affected system	Reset
27	F/CTL ELAC 1(2) FAULT F/CTL ALTN LAW F/CTL ELAC 1(2) PITCH FAULT	ELAC	– Refer to the FCOM 3.02.27, if applicable.
	ELAC or SEC malfunction	ELAC or SEC	WARNING : Do not reset more than one computer at a time. . It is possible to reset the flight control computers in flight, even if not requested by the ECAM, provided only one reset is performed at a time : For the ELAC only, in case of uncommanded maneuvers during the flight, the reset is not recommended.
28	Loss of fuel quantity indication	FQIC	<u>On ground, or in flight :</u> – Pull the C/B of the affected channel : . Channel 1 A13 on 49VU . Channel 2 M27 on 121VU – Wait 5 seconds, before pushing the C/B. <i>Note :</i> 1) The fuel quantity indication will be re-established within one minute. 2) The fuel leak detection function will be lost for the remainder of the flight. The flight crew must monitor the fuel quantity according to FCOM 3.03.15.

ATA	System malfunction or ECAM Warning/Caution	Affected system	Reset
30	ANTI ICE L(R) WINDSHIELD (WINDOW)	WHC	Refer to the FCOM 3.02.30, if applicable.
31	FWS FWC 1(2) FAULT	FWC	On ground, or in flight : Pull, then push, the C/B of the affected FWC – FWC 1 F01 ON 49VU – FWC 2 Q7 ON 121VU
32	Braking malfunction	BSCU	Refer to 3.04.32 or OEB 50 if applicable.
	L/G LGCIU 1(2) FAULT	LGCIU 1(2)	On ground only : LGCIU 1 : Pull C/B Q34 on 121VU, then C09 on 49VU. Then push C/B C09 and C/B Q34. LGCIU 2 : Pull then push C/B Q35 on 121VU.
34	NAV TCAS FAULT	TCAS	On ground only : – Pull C/B K10 on 121VU. – Wait 5 seconds, then push the C/B.
38	Failure messages on the CIDS FAP in the cabin	Vacuum System Controller	On ground, or in flight : – Pull C/B 35 MG on 2001VU, aft cabin, – Wait 30 seconds, then push the C/B.
70	ENG IGN A+B FAULT	FADEC and EIU	Refer to the FCOM 3.02.70, if applicable.
	ENG 1(2) FADEC A(B) FAULT	FADEC	Refer to the FCOM 3.02.70, if applicable.

ATA	System Malfunction or ECAM Warning/Caution	Affected System	REMARKS
30	ANTI ICE L(R) WINDSHIELD (WINDOW)	WHC	REFER to the FCOM 3.02.30, if applicable.
31	FWS FWC 1(2) FAULT	FWC	On ground, or in flight : Pull, then push, the C/B of the affected FWC – FWC 1.F01 ON 49VU – FWC 2.Q7 ON 121VU
32	Braking Malfunction	BSCU	Refer to 3.04.32, or OEB 50, if applicable.
	L/G LGCIU 1(2) FAULT	LGCIU 1(2)	On ground only : LGCIU 1 : Pull C/B Q34 on 121VU, then C09 on 49VU. Then push C/B C09 and C/B Q34. LGCIU 2 : Pull then push C/B Q35 on 121VU.
34	NAV TCAS FAULT	TCAS	On ground only : – Pull C/B K10 on 121VU. – Wait 5 seconds, then push the C/B.
38	Failure messages on the CIDS FAP in the cabin	Vacuum System Controller	On ground, or in flight : – Pull C/B 35 MG on 2001VU, aft cabin, – Wait 30 seconds, then push the C/B.
46	ATSU Malfunction	ATSU	An ATSU reset should be attempted, if : key selection has no effect on any of the MCDU ATSU DATALINK submenus. On ground, or in flight : – Pull the C/Bs in the following order : L16, L15 on 121VU – Wait 5 seconds, then : – Push the C/Bs in the following order : L15, L16.
70	ENG IGN A+B FAULT	FADEC and EIU	Refer to the FCOM 3.02.70, if applicable.
	ENG 1(2) FADEC A(B) FAULT	FADEC	Refer to the FCOM 3.02.70, if applicable.

R
R
R

ECAM ADVISORY CONDITIONS

SYSTEM	CONDITIONS	RECOMMENDED ACTION
CAB PRESS	CAB VERTICAL SPEED V/S > 1800 ft/min	CPC changeover may be attempted : MODE SEL MAN Wait 10 seconds, then : MODE SEL AUTO
	CAB ALTITUDE altitude ≥ 8800 ft	MODE SEL MAN Manual pressure control
	CAB DIFF PRESS ΔP ≥ 1.5 psi in phase 7	LDG ELEV MAN ADJUST If unsuccessful : MODE SEL MAN Manual pressure control
ELEC	IDG OIL TEMP T ≥ 147°C	Reduce IDG load, if possible (GALLEY or GEN OFF). If required, restore when the temperature has dropped. Restrict generator use to a short time, if the temperature rises again excessively.
FUEL	Difference between wing fuel quantities is greater than 1500 kg (3307 lb).	FUEL MANAGEMENT CHECK If a fuel leak is suspected, refer to the FUEL LEAK procedure. For limitations, see 3.01.28.
	Fuel is temp greater than : 45°C in inner cell, or 55° in outer cell.	GALLEY OFF
	Fuel temp lower than – 40°C in inner or outer cell.	Consider descending to a lower altitude, and/or increasing Mach to increase TAT.
OXY	Cockpit oxygen bottle pressure < 800 psi.	If mask is not being used, check if it is correctly stowed, as per FCOM 1.35.20.
APU	FLAP OPEN Flap not fully closed when APU master switch is off.	
	EGT > EGT MAX – 33°C (inhibited during APU start).	
	OIL QTY (LOW OIL LEVEL message pulses).	If there is no oil leak, then the remaining oil quantity allows normal APU operation for about 10 hours.

ATA	System Malfunction or ECAM Warning/Caution	Affected System	REMARKS
30	ANTI ICE L(R) WINDSHIELD (WINDOW)	WHC	REFER to the FCOM 3.02.30, if applicable.
31	FWS FWC 1(2) FAULT	FWC	On ground, or in flight : Pull, then push, the C/B of the affected FWC – FWC 1.F01 ON 49VU – FWC 2.Q7 ON 121VU
32	Braking Malfunction	BSCU	Refer to 3.04.32, or OEB 50, if applicable.
	L/G LGCIU 1(2) FAULT	LGCIU 1(2)	On ground only : LGCIU 1 : Pull C/B Q34 on 121VU, then C09 on 49VU. Then push C/B C09 and C/B Q34. LGCIU 2 : Pull then push C/B Q35 on 121VU.
34	NAV TCAS FAULT	TCAS	On ground only : – Pull C/B K10 on 121VU. – Wait 5 seconds, then push the C/B.
38	Failure messages on the CIDS FAP in the cabin	Vacuum System Controller	On ground, or in flight : – Pull C/B 35 MG on 2001VU, aft cabin, – Wait 30 seconds, then push the C/B.
46	ATSU Malfunction	ATSU	An ATSU reset should be attempted, if : key selection has no effect on any of the MCDU ATSU DATALINK submenus. On ground, or in flight : – Pull the C/Bs in the following order : L16, L15 on 121VU – Wait 5 seconds, then : – Push the C/Bs in the following order : L15, L16.
70	ENG IGN A+B FAULT	FADEC and EIU	Refer to the FCOM 3.02.70, if applicable.
	ENG 1(2) FADEC A(B) FAULT	FADEC	Refer to the FCOM 3.02.70, if applicable.

R
R
R

ECAM ADVISORY CONDITIONS

SYSTEM	CONDITIONS	RECOMMENDED ACTION
CAB PRESS	CAB VERTICAL SPEED V/S > 1800 ft/min	CPC changeover may be attempted : MODE SEL MAN Wait 10 seconds, then : MODE SEL AUTO
	CAB ALTITUDE altitude ≥ 8800 ft	MODE SEL MAN Manual pressure control
	CAB DIFF PRESS ΔP ≥ 1.5 psi in phase 7	LDG ELEV MAN ADJUST If unsuccessful : MODE SEL MAN Manual pressure control
ELEC	IDG OIL TEMP T ≥ 147°C	Reduce IDG load, if possible (GALLEY or GEN OFF). If required, restore when the temperature has dropped. Restrict generator use to a short time, if the temperature rises again excessively.
FUEL	Difference between wing fuel quantities is greater than 1500 kg (3307 lb).	FUEL MANAGEMENT CHECK If a fuel leak is suspected, refer to the FUEL LEAK procedure. For limitations, see 3.01.28.
	Fuel is temp greater than : 45°C in inner cell, or 55° in outer cell.	GALLEY OFF
	Fuel temp lower than – 40°C in inner or outer cell.	Consider descending to a lower altitude, and/or increasing Mach to increase TAT.
OXY	Cockpit oxygen bottle pressure < 600 psi.	If mask is not being used, check if it is correctly stowed, as per FCOM 1.35.20.
APU	FLAP OPEN Flap not fully closed when APU master switch is off.	
	EGT > EGT MAX – 33°C (inhibited during APU start).	
	OIL QTY (LOW OIL LEVEL message pulses).	If there is no oil leak, then the remaining oil quantity allows normal APU operation for about 10 hours.

ATA	System Malfunction or ECAM Warning/Caution	Affected System	REMARKS
30	ANTI ICE L(R) WINDSHIELD (WINDOW)	WHC	REFER to the FCOM 3.02.30, if applicable.
31	FWS FWC 1(2) FAULT	FWC	On ground, or in flight : Pull, then push, the C/B of the affected FWC – FWC 1.F01 ON 49VU – FWC 2.Q7 ON 121VU
32	Braking Malfunction	BSCU	Refer to 3.04.32, or OEB 50, if applicable.
	L/G LGCIU 1(2) FAULT	LGCIU 1(2)	On ground only : LGCIU 1 : Pull C/B Q34 on 121VU, then C09 on 49VU. Then push C/B C09 and C/B Q34. LGCIU 2 : Pull then push C/B Q35 on 121VU.
34	NAV TCAS FAULT	TCAS	On ground only : – Pull C/B K10 on 121VU. – Wait 5 seconds, then push the C/B.
38	Failure messages on the CIDS FAP in the cabin	Vacuum System Controller	On ground, or in flight : – Pull C/B 35 MG on 2001VU, aft cabin, – Wait 30 seconds, then push the C/B.
46	ATSU Malfunction	ATSU	An ATSU reset should be attempted, if : key selection has no effect on any of the MCDU ATSU DATALINK submenus. On ground, or in flight : – Pull the C/Bs in the following order : L16, L15 on 121VU – Wait 5 seconds, then : – Push the C/Bs in the following order : L15, L16.
70	ENG IGN A+B FAULT	FADEC and EIU	Refer to the FCOM 3.02.70, if applicable.
	ENG 1(2) FADEC A(B) FAULT	FADEC	Refer to the FCOM 3.02.70, if applicable.

R
R
R

ECAM ADVISORY CONDITIONS

SYSTEM	CONDITIONS	RECOMMENDED ACTION
CAB PRESS	CAB VERTICAL SPEED V/S > 1800 ft/min	CPC changeover may be attempted : MODE SEL MAN Wait 10 seconds, then : MODE SEL AUTO
	CAB ALTITUDE altitude ≥ 8800 ft	MODE SEL MAN Manual pressure control
	CAB DIFF PRESS ΔP ≥ 1.5 psi in phase 7	LDG ELEV MAN ADJUST If unsuccessful : MODE SEL MAN Manual pressure control
ELEC	IDG OIL TEMP T ≥ 147°C	Reduce IDG load, if possible (GALLEY or GEN OFF). If required, restore when the temperature has dropped. Restrict generator use to a short time, if the temperature rises again excessively.
FUEL	Difference between wing fuel quantities is greater than 1500 kg (3307 lb).	FUEL MANAGEMENT CHECK If a fuel leak is suspected, refer to the FUEL LEAK procedure. For limitations, see 3.01.28.
	Fuel is temp greater than : 45°C in the wing tank.	GALLEY OFF
	Fuel temp lower than – 40°C in inner or outer cell.	Consider descending to a lower altitude, and/or increasing Mach to increase TAT.
OXY	Cockpit oxygen bottle pressure < 600 psi.	If mask is not being used, check if it is correctly stowed, as per FCOM 1.35.20.
APU	FLAP OPEN Flap not fully closed when APU master switch is off.	
	EGT > EGT MAX – 33°C (inhibited during APU start).	
	OIL QTY (LOW OIL LEVEL message pulses).	If there is no oil leak, then the remaining oil quantity allows normal APU operation for about 10 hours.

ATA	System Malfunction or ECAM Warning/Caution	Affected System	REMARKS
30	ANTI ICE L(R)/WINDSHIELD (WINDOW)	WHC	Refer to the FCOM 3.02.30, if applicable.
31	FWS FWC 1(2) FAULT	FWC	On ground, or in flight : Pull, then push, the C/B of the affected FWC: – FWC 1. F01 ON 49VU – FWC 2. Q7 ON 121VU
32	Braking Malfunction	BSCU	Refer to the 3.04.32, or OEB 50, if applicable.
	L/G LGCIU 1(2) FAULT	LGCIU 1(2)	On ground only : LGCIU 1 : Pull C/B Q34 on 121VU, then C09 on 49VU. Then push C/B C09 and C/B Q34. LGCIU 2 : Pull then push C/B Q35 on 121VU.
34	NAV TCAS FAULT	TCAS	On ground only : – Pull C/B K10 on 121VU. – Wait 5 seconds, the push the C/B.
46	ATSU Malfunction	ATSU	An ATSU reset should be attempted, if : key selection has no effect on any of the MCDU ATSU DATALINK submenus. On ground, or in flight : – Pull the C/Bs in the following order : L16, L15 on 121VU – Wait 5 seconds, then : – Push the C/Bs in the following order : L15, L16.
70	ENG IGN A+B FAULT	FADEC and EIU	Refer to the FCOM 3.02.70, if applicable.
	ENG 1(2) FADEC A(B) FAULT	FADEC	Refer to the FCOM 3.02.70, if applicable.

R
R
R

ECAM ADVISORY CONDITIONS

SYSTEM	CONDITIONS	RECOMMENDED ACTION
CAB PRESS	CAB VERTICAL SPEED V/S > 1800 ft/min	CPC changeover may be attempted : MODE SEL MAN Wait 10 seconds, then : MODE SEL AUTO
	CAB ALTITUDE altitude ≥ 8800 ft	MODE SEL MAN Manual pressure control
	CAB DIFF PRESS ΔP ≥ 1.5 psi in phase 7	LDG ELEV MAN ADJUST If unsuccessful : MODE SEL MAN Manual pressure control
ELEC	IDG OIL TEMP T ≥ 147°C	Reduce IDG load, if possible (GALLEY or GEN OFF). If required, restore when the temperature has dropped. Restrict generator use to a short time, if the temperature rises again excessively.
FUEL	Difference between wing fuel quantities is greater than 1500 kg (3307 lb).	FUEL MANAGEMENT CHECK If a fuel leak is suspected, refer to the FUEL LEAK procedure. For limitations, see 3.01.28.
	Fuel is temp greater than : 45°C in inner cell, or 55° in outer cell.	GALLEY OFF
	Fuel temp lower than – 40°C in inner or outer cell.	Consider descending to a lower altitude, and/or increasing Mach to increase TAT.
OXY	Cockpit oxygen bottle pressure < 600 psi.	If mask is not being used, check if it is correctly stowed, as per FCOM 1.35.20.
APU	FLAP OPEN Flap not fully closed when APU master switch is off.	
	EGT > EGT MAX – 33°C (inhibited during APU start).	
	OIL QTY (LOW OIL LEVEL message pulses).	If there is no oil leak, then the remaining oil quantity allows normal APU operation for about 10 hours.

ECAM ADVISORY CONDITIONS (Cont'd)

SYSTEM	CONDITIONS	RECOMMENDED ACTION
ENG	OIL PRESS P < 80 PSI	<p>. If oil pressure is between 80 and 60 psi, continue normal engine operation.</p> <p>. If oil pressure is below 60 psi (red indication), without the ENG OIL LO PR warning, continue normal engine operation (it can be assumed that the oil pressure transducer is faulty).</p> <p>In both cases, monitor other engine parameters, especially oil temperature and quantity.</p>
	OIL TEMP T > 155°C	<p>An oil temperature increase during normal steady-state operations indicates a system malfunction, and should be closely monitored for other symptoms of engine malfunction.</p> <p><i>Note : If the OIL TEMP increase follows thrust reduction, increasing thrust may reduce oil temperature.</i></p> <p>In addition, an oil temperature increase could be related to the IDG oil cooling system. To reduce oil temperature increases before limits are reached, the following is recommended :</p> <ol style="list-style-type: none"> 1. <u>Low Speed</u> - Increase engine speed to increase fuel flow, and thereby cool IDG oil. 2. <u>High Speed</u> - Reduce generator load, or turn off generator. If oil temperature continues to rise, mechanically disconnect IDG.
	OIL QTY < 5 qt	If oil quantity is low at a high power setting, expect level increase after power reduction.
	NAC TEMP ≥ 320°C	Monitor engine parameters and crosscheck with other engine.
	VIBRATION N1 ≥ 5 units N2 ≥ 5 units	Refer to the HIGH ENGINE VIBRATION procedure.

TAILSTRIKE

In the event of a tailstrike, apply the following procedure :

LAND ASAP

- MAX FL 100 or MSA

500 feet/minute should be targeted for the climb, to minimize pressure changes, and for passenger and crew comfort. Similarly, the rate of descent must be limited to about 1000 feet/minute, except for the final approach that must be performed normally.

Notify the ATC of the aircraft's rate of climb.

- RAM AIR ON
- PACK 1 and 2 OFF

CIRCLING APPROACH WITH ONE ENGINE INOPERATIVE

– LANDING WEIGHT CHECK

● **If the aircraft weight is above the maximum weight for circling in CONF 3 (given in the table below) :**

The aircraft cannot maintain flight level with CONF 3 and the landing gear down.

– FOR LDG USE FLAP 3

Conf 3 is preferred, to minimize a configuration change in short final.

– GPWS LDG FLAP 3 ON

– Delay gear extension.

NOTE : – *If the approach is flown at less than 750 feet RA, the "L/G NOT DOWN" warning will be triggered. The pilot can cancel the aural warning by pressing the EMER CANC pushbutton, located on the ECAM control panel.*

– *A "TOO LOW GEAR" warning is to be expected, if the landing gear is not downlocked at 500 feet RA.*

MAXIMUM WEIGHT FOR CIRCLING IN CONF 3 (1000 KG)

OAT (°C)	AIRPORT ELEVATION (feet)							
	0	2000	4000	6000	8000	10000	12000	14000
0	70.0	69.0	68.0	67.0	65.0	64.0	62.0	57.0
5	70.0	69.0	68.0	67.0	65.0	64.0	60.0	55.0
10	70.0	69.0	68.0	67.0	65.0	61.0	57.0	52.0
15	70.0	69.0	68.0	66.0	63.0	59.0	54.0	50.0
20	70.0	69.0	66.0	64.0	61.0	56.0	52.0	48.0
25	70.0	67.0	64.0	62.0	58.0	54.0	50.0	46.0
30	67.0	65.0	63.0	60.0	56.0	51.0	47.0	
35	65.0	62.0	60.0	57.0	53.0	49.0		
40	62.0	60.0	58.0	54.0				
45	59.0	57.0	55.0					
50	56.0	54.0						
55	53.0							

CIRCLING APPROACH WITH ONE ENGINE INOPERATIVE

– LANDING WEIGHT CHECK

● **If the aircraft weight is above the maximum weight for circling in CONF 3 (given in the table below) :**

The aircraft cannot maintain flight level with CONF 3 and the landing gear down.

– FOR LDG USE FLAP 3

Conf 3 is preferred, to minimize a configuration change in short final.

– GPWS LDG FLAP 3 ON

– Delay gear extension.

NOTE : – *If the approach is flown at less than 750 feet RA, the "L/G NOT DOWN" warning will be triggered. The pilot can cancel the aural warning by pressing the EMER CANC pushbutton, located on the ECAM control panel.*

– *A "TOO LOW GEAR" warning is to be expected, if the landing gear is not downlocked at 500 feet RA.*

MAXIMUM WEIGHT FOR CIRCLING IN CONF 3 (1000 KG)

OAT (°C)	AIRPORT ELEVATION (feet)							
	0	2000	4000	6000	8000	10000	12000	14000
0	71.0	69.0	68.0	67.0	66.0	64.0	62.0	57.0
5	71.0	69.0	68.0	67.0	66.0	64.0	60.0	55.0
10	71.0	69.0	68.0	67.0	65.0	62.0	57.0	53.0
15	71.0	69.0	68.0	66.0	63.0	59.0	55.0	50.0
20	71.0	69.0	67.0	64.0	61.0	57.0	52.0	48.0
25	71.0	67.0	65.0	62.0	59.0	54.0	50.0	46.0
30	68.0	65.0	63.0	60.0	56.0	52.0	47.0	
35	65.0	63.0	61.0	57.0	54.0	49.0		
40	63.0	60.0	58.0	55.0				
45	60.0	57.0	55.0					
50	57.0	54.0						
55	53.0							

CIRCLING APPROACH WITH ONE ENGINE INOPERATIVE

– LANDING WEIGHT CHECK

● **If the aircraft weight is above the maximum weight for circling in CONF 3 (given in the table below) :**

The aircraft cannot maintain flight level with CONF 3 and the landing gear down.

– FOR LDG USE FLAP 3

Conf 3 is preferred, to minimize a configuration change in short final.

– GPWS LDG FLAP 3 ON

– Delay gear extension.

NOTE : – *If the approach is flown at less than 750 feet RA, the "L/G NOT DOWN" warning will be triggered. The pilot can cancel the aural warning by pressing the EMER CANC pushbutton, located on the ECAM control panel.*

– *A "TOO LOW GEAR" warning is to be expected, if the landing gear is not downlocked at 500 feet RA.*

MAXIMUM WEIGHT FOR CIRCLING IN CONF 3 (1000 KG)

OAT (°C)	AIRPORT ELEVATION (feet)							
	0	2000	4000	6000	8000	10000	12000	14000
0	76	74	71	68	64	61	58	54
5	76	74	71	68	64	61	56	52
10	76	74	71	68	64	59	54	
15	76	74	71	67	61	57	52	
20	76	74	69	64	59	54		
25	76	71	66	61	56			
30	73	68	64	59	54			
35	69	65	61	57	52			
40	66	62	59	55				
45	63	60	57					
50	60	57						
55	57							

CONTENTS

. SPEEDS	4.01
. LANDING DISTANCE WITHOUT AUTOBRAKE - CONF 3	4.02
. LANDING DISTANCE WITHOUT AUTOBRAKE - CONF FULL ..	4.03
. AUTOLAND LANDING DISTANCE WITH AUTOBRAKE	4.04
. <u>ONE ENGINE OUT</u>	
MAX ALTITUDE	4.05
GROSS FLIGHT PATH DESCENT AT GREEN DOT SPEED ..	4.06
LONG RANGE CRUISE	4.07
IN CRUISE QUICK CHECK	4.08
. <u>ALL ENGINES</u>	
MAX/OPT ALTITUDES	4.09
IN CRUISE QUICK CHECK	4.10
COST INDEX	4.11
DESCENT	4.12
DIVERSION	4.13
. FLIGHT WITHOUT CAB PRESS	4.14
. GROUND DISTANCE – AIR DISTANCE CONVERSION	4.15
. IAS- MACH CONVERSION	4.16

R

SPEEDS

OPERATING SPEEDS (KT)					
CG \geq 25 %					
W (1000 KG)	F	S	Green dot FL < 200*	VLS CONF 3	VREF
40	117	152	160	109	106
44	122	159	168	114	111
48	128	166	176	119	116
52	133	173	184	124	121
56	138	179	192	128	125
60	143	185	200	133	129
64	148	192	208	137	134
68	152	197	216	142	138
72	157	203	224	146	142
76	161	209	232	150	146
78	163	211	236	152	147

For CG < 25 % add 2 knots to VLS and VREF

* Above FL200 add 1 knot per additional 1000 feet

LANDING DISTANCE WITHOUT AUTOBRAKE

The actual landing distance is the distance to come to a complete stop from a point 50 ft above the landing surface. No margin is included in this distance.

CONFIGURATION 3

ACTUAL LANDING DISTANCE (METERS)											
WEIGHT (1000 KG)		46	50	54	58	62	66	70	74	78	
RUNWAY CONDITION	DRY	730	760	800	840	890	970	1060	1160	1250	
	WET	970	1040	1110	1180	1260	1340	1420	1500	1580	
	COVERED WITH	6.3 MM (1/4INCH) WATER	1270	1360	1440	1560	1690	1810	1940	2070	2180
		12.7 MM (1/2INCH) WATER	1230	1310	1400	1510	1620	1730	1840	1970	2060
		6.3 MM (1/4INCH) SLUSH	1230	1310	1400	1480	1570	1660	1780	1900	2000
		12.7 MM (1/2INCH) SLUSH	1190	1270	1350	1430	1520	1600	1710	1810	1900
		COMPACTED SNOW	1230	1310	1380	1460	1540	1620	1690	1770	1830
ICE	2320	2480	2650	2810	2970	3140	3300	3470	3600		

CORRECTIONS

	CORRECTION ON ACTUAL LANDING DISTANCE							
	dry runway	wet runway	runway covered with					
			1/4 inch water	1/2 inch water	1/4 inch slush	1/2 inch slush	compacted snow	ice
per 1000 ft above SL	+ 3 %	+ 4 %	+ 4 %	+ 4 %	+ 5 %	+ 5 %	+ 4 %	+ 5 %
per 10 kt headwind	No correction for headwind due to wind correction on approach speed							
per 10 kt tailwind	+ 17 %	+ 21 %	+ 24 %	+ 20 %	+ 22 %	+ 20 %	+ 16 %	+ 24 %
forward C.G.	+ 2 %	+ 3 %	+ 3 %	+ 3 %	+ 3 %	+ 2 %	+ 3 %	+ 3 %
2 reversers operative	- 5 %	- 12 %	- 15 %	- 15 %	- 14 %	- 13 %	- 12 %	- 27 %
Per 5 kt speed increment (and no failure) add 8% (all runways)								

NOTE : – THE ABOVE DISTANCES ARE GIVEN FOR USE IN FLIGHT
– BEFORE DEPARTURE REFER TO FCOM

SPEEDS

OPERATING SPEEDS (KT)					
W (1000 KG)	F	S	Green dot FL < 200*	VLS CONF 3	VREF
44	123	161	173	115	**
48	128	168	181	120	112
52	133	175	189	125	117
56	139	181	197	130	121
60	143	187	205	134	125
64	148	194	213	139	129
68	153	200	221	143	133
72	157	205	229	147	137
76	161	211	237	151	141

* Above FL200 add 1 knot per additional 1000 feet

** VREF is limited by VMCL = 109 knots

LANDING DISTANCE WITHOUT AUTOBRAKE

The actual landing distance is the distance to come to a complete stop from a point 50 ft above the landing surface. No margin is included in this distance.

CONFIGURATION 3

		ACTUAL LANDING DISTANCE (METERS)										
WEIGHT (1000 KG)		40	44	48	52	56	60	64	68	72	76	
RUNWAY CONDITION	DRY	670	710	740	780	820	870	920	1000	1090	1160	
	WET	890	960	1030	1110	1180	1260	1340	1420	1490	1530	
	COVERED WITH	6.3 MM (1/4INCH) WATER	1220	1320	1430	1550	1660	1790	1910	2050	2140	2210
		12.7 MM (1/2INCH) WATER	1170	1260	1360	1470	1580	1700	1800	1920	2020	2080
		6.3 MM (1/4INCH) SLUSH	1190	1280	1380	1470	1570	1690	1820	1930	2020	2090
		12.7 MM (1/2INCH) SLUSH	1150	1240	1330	1420	1510	1620	1730	1850	1920	1980
		COMPACTED SNOW	1170	1240	1320	1400	1480	1560	1640	1720	1770	1800
		ICE	2390	2530	2670	2820	2970	3120	3280	3420	3530	3600

CORRECTIONS

	CORRECTION ON ACTUAL LANDING DISTANCE							
	dry runway	wet runway	runway covered with					
			1/4 inch water	1/2 inch water	1/4 inch slush	1/2 inch slush	compacted snow	ice
per 1000 ft above SL	+ 3 %	+ 4 %	+ 4 %	+ 4 %	+ 5 %	+ 5 %	+ 4 %	+ 5 %
per 10 kt headwind	No correction for headwind due to wind correction on approach speed							
per 10 kt tailwind	+ 17 %	+ 22 %	+ 24 %	+ 22 %	+ 23 %	+ 21 %	+ 18 %	+ 33 %
2 reversers operative	-4 %	-9 %	-16 %	-14 %	-15 %	-13 %	-11 %	-27 %
Per 5 kt speed increment (and no failure) add 8% (all runways)								

NOTE : – THE ABOVE DISTANCES ARE GIVEN FOR USE IN FLIGHT
– BEFORE DEPARTURE REFER TO FCOM

SPEEDS

OPERATING SPEEDS (KT)					
W (1000 KG)	F	S	Green dot FL < 200*	VLS CONF 3	VREF
52	130	168	188	121	116
56	135	174	194	125	121
60	140	180	200	130	125
64	144	186	206	134	129
68	149	192	212	138	133
72	153	197	218	142	137
76	157	203	224	146	141
80	161	208	230	150	144
84	165	213	236	154	148
88	169	218	242	157	151
92	173	223	248	161	155
94	175	226	251	163	157

* Above FL200, add 1 knot per additional 1000 feet

LANDING DISTANCE WITHOUT AUTOBRAKE

The actual landing distance is the distance to come to a complete stop from a point 50 ft above the landing surface. No margin is included in this distance.

CONFIGURATION 3

ACTUAL LANDING DISTANCE (METERS)												
WEIGHT (1000 KG)		58	62	66	70	74	78	82	86	90	94	
RUNWAY CONDITION	DRY	860	900	940	980	1020	1070	1150	1370	1470	1570	
	WET	1110	1180	1250	1330	1400	1470	1540	1670	1770	1860	
	COVERED WITH	6.3 MM (1/4INCH) WATER	1550	1660	1760	1880	1990	2080	2200	2310	2420	2520
		12.7 MM (1/2INCH) WATER	1480	1580	1680	1790	1880	1980	2070	2190	2300	2390
		6.3 MM (1/4INCH) SLUSH	1490	1580	1670	1770	1870	1980	2070	2170	2280	2370
		12.7 MM (1/2INCH) SLUSH	1440	1520	1610	1710	1800	1890	1990	2080	2190	2270
		COMPACTED SNOW	1390	1460	1530	1600	1670	1730	1790	1850	1920	1980
		ICE	2780	2910	3050	3190	3310	3440	3560	3700	3830	3950

CORRECTIONS

	CORRECTION ON ACTUAL LANDING DISTANCE							
	dry runway	wet runway	runway covered with					
			1/4 inch water	1/2 inch water	1/4 inch slush	1/2 inch slush	compacted snow	ice
per 1000 ft above SL	+ 3 %	+ 4 %	+ 4 %	+ 4 %	+ 5 %	+ 5 %	+ 4 %	+ 5 %
per 10 kt headwind	No correction for headwind due to wind correction on approach speed							
per 10 kt tailwind	+ 16 %	+ 21 %	+ 22 %	+ 20 %	+ 21 %	+ 20 %	+ 16 %	+ 26 %
2 reversers operative	-5 %	-8 %	-17 %	-15 %	-16 %	-14 %	-11 %	-29 %
Per 5 kt speed increment (and no failure) add 8% (all runways)								

NOTE : – THE ABOVE DISTANCES ARE GIVEN FOR USE IN FLIGHT
– BEFORE DEPARTURE REFER TO FCOM

LANDING DISTANCE WITHOUT AUTOBRAKE

The actual landing distance is the distance to come to a complete stop from a point 50 ft above the landing surface. No margin is included in this distance.

CONFIGURATION FULL

ACTUAL LANDING DISTANCE (METERS)												
WEIGHT (1000 KG)		58	62	66	70	74	78	82	86	90	94	
RUNWAY CONDITION	DRY	820	850	890	930	970	1020	1080	1290	1380	1470	
	WET	1040	1100	1160	1230	1290	1360	1430	1540	1640	1720	
	COVERED WITH	6.3 MM (1/4INCH) WATER	1430	1530	1640	1740	1840	1940	2030	2140	2240	2340
		12.7 MM (1/2INCH) WATER	1380	1470	1570	1670	1760	1840	1930	2030	2130	2220
		6.3 MM (1/4INCH) SLUSH	1390	1470	1560	1640	1730	1820	1920	2020	2120	2210
		12.7 MM (1/2INCH) SLUSH	1350	1430	1510	1590	1670	1750	1840	1930	2030	2110
		COMPACTED SNOW	1310	1380	1440	1510	1570	1630	1680	1750	1810	1860
		ICE	2590	2720	2850	2970	3090	3210	3320	3450	3580	3690

CORRECTIONS

	CORRECTION ON ACTUAL LANDING DISTANCE							
	dry runway	wet runway	runway covered with					
			1/4 inch water	1/2 inch water	1/4 inch slush	1/2 inch slush	compacted snow	ice
per 1000 ft above SL	+ 3 %	+ 4 %	+ 4 %	+ 4 %	+ 5 %	+ 5 %	+ 4 %	+ 4 %
per 10 kt headwind	No correction for headwind due to wind correction on approach speed							
per 10 kt tailwind	+ 16 %	+ 21 %	+ 24 %	+ 21 %	+ 22 %	+ 20 %	+ 16 %	+ 27 %
2 reversers operative	-4 %	-8 %	-16 %	-14 %	-15 %	-14 %	-11 %	-28 %
Per 5 kt speed increment (and no failure) add 8% (all runways)								

NOTE: – THE ABOVE DISTANCES ARE GIVEN FOR USE IN FLIGHT
– BEFORE DEPARTURE REFER TO FCOM

AUTOLAND LANDING DISTANCE WITH AUTOBRAKE

CONFIGURATION 3

R

ACTUAL LANDING DISTANCE (METERS)								CORRECTIONS (%) ON LANDING DISTANCE				
WEIGHT (1000 KG)		54	62	70	78	86	94	PER 1000FT ABOVE SL	2 REV. OP.	PER 10KT TAIL WIND	PER 10KT HEAD WIND	
RUNWAY CONDITION	MODE											
DRY	MED	1340	1440	1550	1650	1810	1970	+ 5	0	+13	-2	
	LOW	1920	2100	2290	2460	2640	2810	+ 3	0	+15	-2	
WET	MED	1410	1540	1690	1830	2010	2200	+ 6	-3	+17	-3	
	LOW	1920	2100	2290	2460	2640	2810	+ 3	0	+15	-2	
C O V E R E D W I T H	6.3 MM (1/4 INCH) WATER	MED	1770	1990	2210	2410	2640	2860	+ 6	-17	+21	-4
	LOW	1900	2090	2300	2490	2720	2940	+ 4	0	+18	-2	
12.7 MM (1/2 INCH) WATER	MED	1690	1880	2090	2280	2490	2700	+ 5	-16	+19	-3	
	LOW	1890	2070	2260	2440	2640	2830	+ 4	0	+16	-2	
6.3 MM (1/4 INCH) SLUSH	MED	1700	1890	2100	2290	2490	2690	+ 7	-16	+21	-3	
	LOW	1860	2030	2220	2400	2590	2790	+ 5	0	+17	-2	
12.7 MM (1/2 INCH) SLUSH	MED	1640	1810	2000	2180	2370	2560	+ 6	-15	+19	-3	
	LOW	1840	2020	2200	2370	2540	2720	+ 4	0	+15	-2	
COMPACTED SNOW	MED	1580	1700	1830	1940	2060	2170	+ 6	-12	+15	-2	
	LOW	1870	2050	2230	2390	2560	2730	+ 4	0	+15	-2	
ICE	MED	2980	3240	3530	3780	4040	4290	+ 6	-29	+25	-4	
	LOW	3000	3260	3550	3800	4060	4320	+ 5	-26	+26	-4	

CONFIGURATION FULL

ACTUAL LANDING DISTANCE (METERS)								CORRECTIONS (%) ON LANDING DISTANCE				
WEIGHT (1000 KG)		54	62	70	78	86	94	PER 1000FT ABOVE SL	2 REV. OP.	PER 10KT TAIL WIND	PER 10KT HEAD WIND	
RUNWAY CONDITION	MODE											
DRY	MED	1280	1370	1460	1530	1660	1800	+ 3	0	+13	-1	
	LOW	1830	1990	2150	2300	2450	2590	+ 3	0	+14	-2	
WET	MED	1330	1440	1560	1670	1820	1980	+ 4	-2	+16	-2	
	LOW	1830	1990	2150	2300	2450	2590	+ 3	0	+14	-2	
C O V E R E D W I T H	6.3 MM (1/4 INCH) WATER	MED	1660	1830	2020	2190	2400	2580	+ 4	-16	+20	-3
	LOW	1810	1980	2150	2310	2490	2660	+ 4	0	+18	-2	
12.7 MM (1/2 INCH) WATER	MED	1590	1760	1920	2080	2250	2430	+ 4	-15	+19	-3	
	LOW	1790	1960	2120	2270	2430	2590	+ 4	0	+15	-2	
6.3 MM (1/4 INCH) SLUSH	MED	1590	1760	1940	2080	2270	2440	+ 5	-16	+20	-3	
	LOW	1770	1930	2080	2220	2380	2540	+ 5	0	+16	-2	
12.7 MM (1/2 INCH) SLUSH	MED	1540	1690	1850	2000	2160	2310	+ 5	-15	+18	-3	
	LOW	1760	1910	2070	2210	2350	2500	+ 4	0	+14	-2	
COMPACTED SNOW	MED	1500	1600	1710	1800	1890	1970	+ 4	-11	+14	-2	
	LOW	1780	1940	2090	2230	2380	2520	+ 4	0	+14	-2	
ICE	MED	2790	3030	3270	3490	3720	3940	+ 5	-28	+25	-4	
	LOW	2810	3050	3290	3510	3740	3960	+ 5	-26	+26	-4	

NOTE : – MAX MODE IS NOT RECOMMENDED AT LANDING

– THE TABLES TAKE INTO ACCOUNT THE APPROACH SPEED INCREMENT LINKED TO HEADWIND AND AUTOLAND. FOR ANY EXTRA SPEED INCREMENT OF 5 KNOTS (AND NO FAILURE) INCREASE LANDING DISTANCE BY 6 % (ALL RUNWAYS).

LANDING DISTANCE WITHOUT AUTOBRAKE

The actual landing distance is the distance to come to a complete stop from a point 50 ft above the landing surface. No margin is included in this distance.

CONFIGURATION FULL

		ACTUAL LANDING DISTANCE (METERS)										
		WEIGHT (1000 KG)		40	44	48	52	56	60	64	68	72
RUNWAY CONDITION	DRY	670	670	690	720	760	790	830	870	940	1010	
	WET	860	880	910	970	1040	1100	1170	1230	1280	1310	
	COVERED WITH											
	6.3 MM (1/4INCH) WATER	1170	1190	1240	1330	1430	1530	1630	1730	1800	1870	
	12.7 MM (1/2INCH) WATER	1120	1140	1190	1280	1370	1460	1560	1660	1730	1770	
	6.3 MM (1/4INCH) SLUSH	1140	1160	1210	1290	1370	1460	1540	1640	1720	1760	
	12.7 MM (1/2INCH) SLUSH	1100	1120	1170	1250	1330	1410	1490	1580	1650	1690	
	COMPACTED SNOW	1130	1140	1180	1250	1320	1390	1460	1520	1570	1590	
ICE	2160	2210	2300	2420	2550	2680	2810	2930	3020	3070		

CORRECTIONS

	CORRECTION ON ACTUAL LANDING DISTANCE							
	dry runway	wet runway	runway covered with					
			1/4 inch water	1/2 inch water	1/4 inch slush	1/2 inch slush	compacted snow	ice
per 1000 ft above SL	+ 3 %	+ 4 %	+ 4 %	+ 4 %	+ 5 %	+ 5 %	+ 4 %	+ 5 %
per 10 kt headwind	No correction for headwind due to wind correction on approach speed							
per 10 kt tailwind	+ 19 %	+ 22 %	+ 25 %	+ 22 %	+ 24 %	+ 21 %	+ 18 %	+ 34 %
2 reversers operative	-3 %	-8 %	-13 %	-12 %	-13 %	-12 %	-10 %	-25 %
Per 5 kt speed increment (and no failure) add 8% (all runways)								

NOTE : – THE ABOVE DISTANCES ARE GIVEN FOR USE IN FLIGHT
– BEFORE DEPARTURE REFER TO FCOM

AUTOLAND LANDING DISTANCE WITH AUTOBRAKE

CONFIGURATION 3

		ACTUAL LANDING DISTANCE (METERS)					CORRECTIONS (%) ON LANDING DISTANCE				
WEIGHT (1000 KG)		40	50	60	70	80	PER 1000FT ABOVE SL	2 REV. OP.	PER 10KT TAIL WIND	PER 10KT HEAD WIND	
RUNWAY CONDITION	MODE										
DRY	MED	1150	1290	1430	1570	1690	+ 3	0	+12	-1	
	LOW	1640	1890	2140	2390	2590	+ 3	0	+15	-2	
WET	MED	1190	1370	1570	1770	1920	+ 4	-2	+18	-2	
	LOW	1640	1890	2140	2390	2590	+ 3	0	+15	-2	
C O V E R E D W I T H	6.3 MM (1/4 INCH) WATER	MED	1500	1790	2080	2390	2650	+ 5	-16	+22	-4
	LOW	1620	1880	2160	2450	2720	+ 4	-0	+19	-2	
12.7 MM (1/2 INCH) WATER	MED	1430	1680	1950	2220	2470	+ 5	-15	+21	-4	
	LOW	1600	1850	2110	2380	2610	+ 4	0	+17	-2	
6.3 MM (1/4 INCH) SLUSH	MED	1450	1700	1970	2260	2480	+ 6	-15	+22	-3	
	LOW	1590	1830	2080	2340	2580	+ 5	-1	+19	-2	
12.7 MM (1/2 INCH) SLUSH	MED	1390	1620	1880	2130	2350	+ 5	-15	+20	-3	
	LOW	1570	1810	2060	2300	2510	+ 5	-0	+16	-2	
COMPACTED SNOW	MED	1400	1570	1750	1920	2030	+ 4	-11	+17	-2	
	LOW	1620	1860	2100	2340	2530	+ 4	-0	+16	-2	
ICE	MED	2700	3050	3430	3790	4070	+ 5	-27	+31	-5	
	LOW	2730	3080	3450	3810	4100	+ 5	-25	+30	-4	

CONFIGURATION FULL

		ACTUAL LANDING DISTANCE (METERS)					CORRECTIONS (%) ON LANDING DISTANCE				
WEIGHT (1000 KG)		40	50	60	70	80	PER 1000FT ABOVE SL	2 REV. OP.	PER 10KT TAIL WIND	PER 10KT HEAD WIND	
RUNWAY CONDITION	MODE										
DRY	MED	1060	1140	1260	1360	1430	+ 3	0	+14	-3	
	LOW	1540	1670	1880	2060	2210	+ 3	0	+16	-3	
WET	MED	1080	1180	1340	1470	1570	+ 4	0	+19	-3	
	LOW	1540	1670	1880	2060	2210	+ 3	0	+16	-3	
C O V E R E D W I T H	6.3 MM (1/4 INCH) WATER	MED	1340	1510	1750	1960	2130	+ 5	-15	+23	-5
	LOW	1510	1650	1860	2070	2240	+ 4	0	+19	-3	
12.7 MM (1/2 INCH) WATER	MED	1280	1440	1640	1850	2010	+ 4	-13	+21	-5	
	LOW	1490	1630	1850	2040	2190	+ 4	-0	+17	-3	
6.3 MM (1/4 INCH) SLUSH	MED	1300	1450	1670	1870	2030	+ 5	-15	+22	-5	
	LOW	1480	1610	1810	1990	2140	+ 5	0	+18	-3	
12.7 MM (1/2 INCH) SLUSH	MED	1250	1390	1590	1770	1920	+ 5	-13	+21	-5	
	LOW	1460	1600	1800	1980	2120	+ 4	0	+16	-3	
COMPACTED SNOW	MED	1260	1380	1520	1640	1710	+ 4	-11	+18	-4	
	LOW	1510	1640	1840	2010	2150	+ 4	-0	+17	-3	
ICE	MED	2360	2590	2890	3170	3370	+ 5	-25	+32	-6	
	LOW	2380	2610	2920	3200	3400	+ 5	-23	+33	-5	

NOTE: – MAX MODE IS NOT RECOMMENDED AT LANDING.

– THE TABLES TAKE INTO ACCOUNT THE APPROACH SPEED INCREMENT LINKED TO HEADWIND AND AUTOLAND. FOR ANY EXTRA SPEED INCREMENT OF 5 KNOTS (AND NO FAILURE) INCREASE LANDING DISTANCE BY 7 % (ALL RUNWAYS).

LANDING DISTANCE WITHOUT AUTOBRAKE

The actual landing distance is the distance to come to a complete stop from a point 50 ft above the landing surface. No margin is included in this distance.

CONFIGURATION FULL

ACTUAL LANDING DISTANCE (METERS)											
WEIGHT (1000 KG)		46	50	54	58	62	66	70	74	78	
RUNWAY CONDITION	DRY	690	730	760	790	830	890	980	1070	1150	
	WET	890	950	1010	1080	1150	1220	1290	1360	1420	
	COVERED WITH	6.3 MM (1/4INCH) WATER	1170	1250	1330	1420	1530	1630	1740	1850	1950
		12.7 MM (1/2INCH) WATER	1140	1220	1290	1380	1470	1580	1680	1780	1860
		6.3 MM (1/4INCH) SLUSH	1130	1210	1290	1370	1450	1530	1620	1720	1800
		12.7 MM (1/2INCH) SLUSH	1100	1180	1250	1330	1400	1480	1560	1660	1730
		COMPACTED SNOW	1140	1220	1290	1360	1430	1500	1570	1650	1700
		ICE	2030	2170	2310	2450	2600	2740	2880	3030	3150

CORRECTIONS

	CORRECTION ON ACTUAL LANDING DISTANCE							
	dry runway	wet runway	runway covered with					
			1/4 inch water	1/2 inch water	1/4 inch slush	1/2 inch slush	compacted snow	ice
per 1000 ft above SL	+ 3 %	+ 4 %	+ 4 %	+ 4 %	+ 5 %	+ 5 %	+ 4 %	+ 5 %
per 10 kt headwind	No correction for headwind due to wind correction on approach speed							
per 10 kt tailwind	+ 18 %	+ 21 %	+ 22 %	+ 20 %	+ 20 %	+ 19 %	+ 17 %	+ 25 %
forward C.G.	+ 2 %	+ 3 %	+ 3 %	+ 3 %	+ 3 %	+ 3 %	+ 3 %	+ 2 %
2 reversers operative	- 5 %	- 11 %	- 14 %	- 13 %	- 13 %	- 12 %	- 11 %	- 24 %
Per 5 kt speed increment (and no failure) add 8% (all runways)								

NOTE: – THE ABOVE DISTANCES ARE GIVEN FOR USE IN FLIGHT
– BEFORE DEPARTURE REFER TO FCOM

AUTOLAND LANDING DISTANCE WITH AUTOBRAKE

CONFIGURATION 3

ACTUAL LANDING DISTANCE (METERS)							CORRECTIONS (%) ON LANDING DISTANCE					
WEIGHT (1000 KG)		40	50	60	70	80	PER 1000FT ABOVE SL	2 REV. OP.	PER 10KT TAIL WIND	PER 10KT HEAD WIND	FWD CG	
RUNWAY CONDITION	MODE											
DRY	MED	1290	1410	1530	1660	1780	+ 3	0	+ 12	-2	+ 1	
	LOW	1760	1990	2220	2450	2680	+ 3	-2	+ 16	-3	+ 2	
WET	MED	1300	1450	1620	1800	1970	+ 4	0	+ 17	-3	+ 2	
	LOW	1760	1990	2220	2450	2680	+ 3	-2	+ 16	-3	+ 2	
C O V E R E D	6.3 MM (1/4 INCH) WATER	MED	1500	1740	2010	2300	2590	+ 5	-13	+ 21	-4	+ 3
	LOW	1740	1960	2210	2490	2760	+ 4	-2	+ 17	-3	+ 1	
R E D	12.7 MM (1/2 INCH) WATER	MED	1450	1660	1900	2170	2440	+ 4	-11	+ 20	-4	+ 2
	LOW	1710	1930	2150	2410	2670	+ 4	-1	+ 16	-3	+ 2	
W I T H	6.3 MM (1/4 INCH) SLUSH	MED	1470	1640	1860	2120	2380	+ 5	-13	+ 21	-4	+ 3
	LOW	1700	1910	2120	2360	2600	+ 5	-1	+ 16	-3	+ 2	
I C E	12.7 MM (1/2 INCH) SLUSH	MED	1410	1570	1770	2000	2220	+ 5	-10	+ 19	-4	+ 2
	LOW	1660	1870	2090	2310	2530	+ 4	-1	+ 15	-3	+ 2	
I C E	COMPACTED SNOW	MED	1470	1620	1770	1930	2070	+ 4	-11	+ 16	-3	+ 2
	LOW	1730	1940	2160	2390	2600	+ 4	-1	+ 15	-3	+ 1	
I C E	ICE	MED	2520	2900	3280	3680	4040	+ 5	-28	+ 23	-5	+ 2
	LOW	2550	2930	3320	3710	4080	+ 5	-24	+ 23	-5	+ 2	

CONFIGURATION FULL

ACTUAL LANDING DISTANCE (METERS)							CORRECTIONS (%) ON LANDING DISTANCE					
WEIGHT (1000 KG)		40	50	60	70	80	PER 1000FT ABOVE SL	2 REV. OP.	PER 10KT TAIL WIND	PER 10KT HEAD WIND	FWD CG	
RUNWAY CONDITION	MODE											
DRY	MED	1170	1310	1440	1560	1670	+ 3	0	+ 13	-3	+ 2	
	LOW	1600	1830	2060	2280	2480	+ 3	0	+ 16	-3	+ 2	
WET	MED	1170	1310	1470	1620	1760	+ 4	0	+ 17	-4	+ 3	
	LOW	1600	1830	2060	2280	2480	+ 3	0	+ 16	-3	+ 2	
C O V E R E D	6.3 MM (1/4 INCH) WATER	MED	1330	1530	1770	2010	2240	+ 4	-11	+ 21	-5	+ 3
	LOW	1570	1800	2030	2250	2480	+ 4	-1	+ 16	-3	+ 2	
R E D	12.7 MM (1/2 INCH) WATER	MED	1290	1480	1690	1910	2130	+ 4	-9	+ 19	-5	+ 3
	LOW	1540	1770	2000	2220	2430	+ 3	-1	+ 15	-3	+ 2	
W I T H	6.3 MM (1/4 INCH) SLUSH	MED	1290	1470	1660	1870	2070	+ 5	-10	+ 20	-5	+ 3
	LOW	1530	1750	1970	2180	2380	+ 4	-1	+ 16	-3	+ 2	
I C E	12.7 MM (1/2 INCH) SLUSH	MED	1260	1420	1590	1780	1960	+ 5	-9	+ 19	-5	+ 3
	LOW	1500	1720	1940	2140	2340	+ 4	-1	+ 16	-3	+ 2	
I C E	COMPACTED SNOW	MED	1310	1470	1620	1760	1880	+ 4	-9	+ 16	-4	+ 3
	LOW	1560	1780	2000	2210	2410	+ 4	-1	+ 16	-3	+ 2	
I C E	ICE	MED	2130	2480	2820	3150	3460	+ 5	-25	+ 25	-5	+ 3
	LOW	2160	2510	2850	3190	3490	+ 5	-19	+ 24	-5	+ 2	

NOTE : - MAX MODE IS NOT RECOMMENDED AT LANDING.

- THE TABLES TAKE INTO ACCOUNT THE APPROACH SPEED INCREMENT LINKED TO HEADWIND AND AUTOLAND. FOR ANY EXTRA SPEED INCREMENT OF 5 KNOTS (AND NO FAILURE) INCREASE LANDING DISTANCE BY 7 % (ALL RUNWAYS).

ONE ENGINE OUT MAX ALTITUDE

GROSS CEILING at LONG RANGE and GREEN DOT SPEEDS
Pack Flow Hi – Anti ice OFF

R

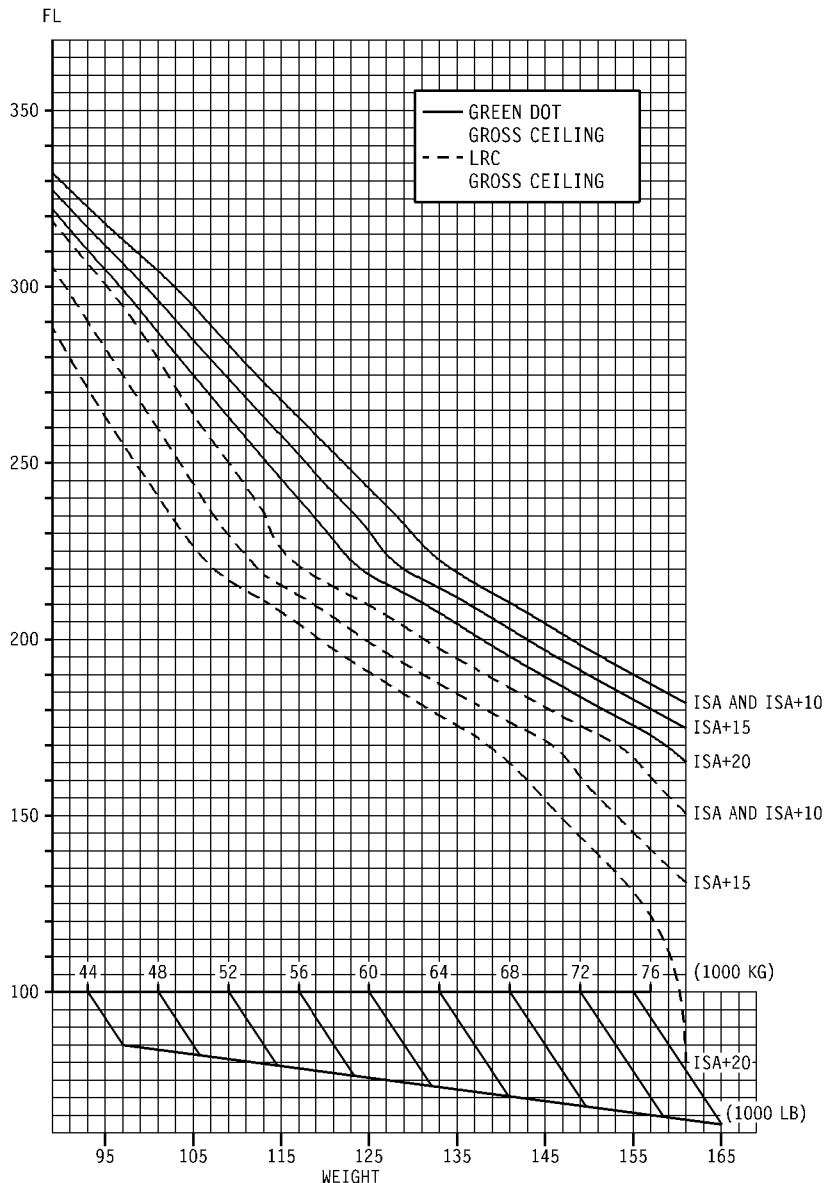

CORRECTIONS

R

		ISA AND ISA + 10	ISA + 15 AND ISA + 20
LONG RANGE	ENGINE ANTI ICE ON	- 1300 FT	- 4000 FT
	TOTAL ANTI ICE ON	- 2700 FT	- 7400 FT
GREEN DOT	ENGINE ANTI ICE ON	- 700 FT	- 900 FT
	TOTAL ANTI ICE ON	- 1700 FT	- 2100 FT

ONE ENGINE OUT

GROSS FLIGHT PATH DESCENT AT GREEN DOT SPEED - 1 ENGINE OUT							
MAX. CONTINUOUS THRUST PACK FLOW HI ANTI-ICING OFF		ISA CG=33.0%		DISTANCE (NM)		TIME (MIN)	
INIT. GW (1000KG)		INITIAL FLIGHT LEVEL		INITIAL SPEED (KT)		FUEL (1000KG) LEVEL OFF (FT)	
	250	290	310	330	350	370	390
50			78 15 191 .4 30800	196 38 193 .9 31000	244 46 195 1.1 31100	276 52 197 1.3 31200	301 56 199 1.3 31200
52			149 29 195 .8 30100	217 41 197 1.1 30200	255 48 199 1.2 30300	283 53 201 1.3 30400	305 56 203 1.4 30400
54		63 12 197 .3 28800	203 39 199 1.1 29200	249 47 201 1.3 29300	282 53 203 1.4 29400	306 57 205 1.5 29500	327 60 207 1.5 29500
56		162 31 201 .9 28100	234 45 203 1.2 28300	274 52 205 1.4 28400	302 57 207 1.5 28400	325 61 209 1.6 28500	343 63 211 1.7 28500
58		205 40 205 1.1 27200	258 49 207 1.4 27300	292 55 209 1.6 27400	317 59 211 1.7 27400	338 63 213 1.7 27500	355 65 215 1.8 27500
60		234 45 209 1.3 26300	275 52 211 1.5 26400	305 58 213 1.7 26400	328 61 215 1.8 26500	347 64 217 1.8 26500	363 67 219 1.9 26500
62	67 13 209 .4 24800	255 49 213 1.5 25400	291 55 215 1.7 25400	318 60 217 1.8 25500	338 63 219 1.9 25500	357 66 221 1.9 25600	372 68 223 2.0 25600
64	160 31 213 1.0 24100	277 53 217 1.6 24400	306 58 219 1.8 24500	331 62 221 1.9 24600	349 65 223 2.0 24600	368 68 225 2.0 24600	383 70 227 2.1 24700
66	204 40 217 1.3 23200	295 56 221 1.8 23500	322 61 223 1.9 23600	344 65 225 2.0 23600	363 68 227 2.1 23600	379 70 229 2.1 23700	395 72 231 2.2 23700
68	239 47 221 1.6 22400	314 60 225 1.9 22600	338 64 227 2.1 22600	360 67 229 2.1 22700	377 70 231 2.2 22700	393 72 233 2.3 22700	407 74 235 2.3 22700
70	224 43 225 1.5 21600	297 56 229 1.9 21700	323 61 231 2.0 21800	345 64 233 2.1 21800	363 67 235 2.2 21800	381 70 237 2.2 21800	
72	218 42 229 1.5 21100	280 53 233 1.8 21200	303 56 235 1.9 21200	322 59 237 2.0 21300	340 62 239 2.0 21300	353 64 241 2.1 21300	
74	227 43 233 1.5 20600	280 52 237 1.8 20700	302 56 239 1.9 20700	319 58 241 2.0 20700	334 61 243 2.0 20700	350 63 245 2.1 20800	
76	239 45 237 1.6 20000	287 53 241 1.9 20100	307 56 243 2.0 20100	322 59 245 2.0 20200	339 61 247 2.1 20200	352 63 249 2.1 20200	
78	240 45 241 1.7 19500	286 52 245 1.9 19600	305 55 247 2.0 19600	322 58 249 2.1 19600	336 60 251 2.1 19600		
CORRECTIONS		DISTANCE		TIME	FUEL	LEVEL OFF	
ENGINE ANTI ICE ON		+ 15 %		+ 15 %	+ 20 %	- 800 FT	
TOTAL ANTI ICE ON		+ 20 %		+ 25 %	+ 30 %	- 1900 FT 3	

ONE ENGINE OUT MAX ALTITUDE

GROSS CEILING at LONG RANGE and GREEN DOT SPEEDS
Pack Flow Hi – Anti ice OFF

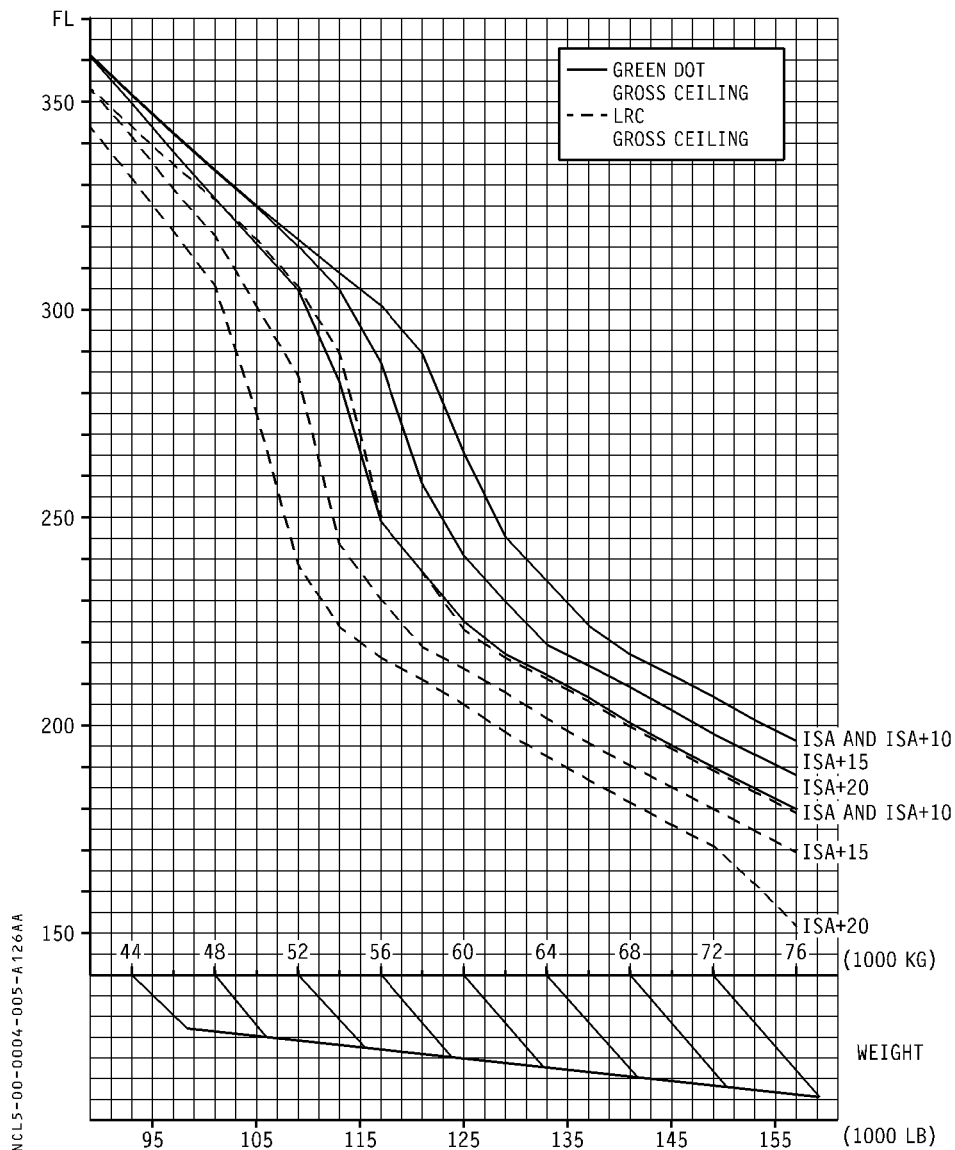

CORRECTIONS

		ISA	ISA + 10	ISA + 15	ISA + 20
LONG RANGE	ENGINE ANTI ICE ON	- 2500 FT	- 2600 FT	- 3600 FT	- 1800 FT
	TOTAL ANTI ICE ON	- 5100 FT	- 5000 FT	- 6000 FT	- 7000 FT
GREEN DOT	ENGINE ANTI ICE ON	- 1700 FT	- 1600 FT	- 1800 FT	- 2400 FT
	TOTAL ANTI ICE ON	- 4200 FT	- 4200 FT	- 4200 FT	- 4800 FT

ONE ENGINE OUT

R

GROSS FLIGHT PATH DESCENT AT GREEN DOT SPEED - 1 ENGINE OUT

MAX. CONTINUOUS THRUST		ISA				DISTANCE (NM)		TIME (MIN)	
PACK FLOW HI		CG=33.0%				INITIAL SPEED(KT)		FUEL(1000KG)	
ANTI-ICING OFF		LEVEL OFF (FT)							
INIT. GW (1000KG)	INITIAL FLIGHT LEVEL								
	250	290	310	330	350	370	390	410	
48					179 32 196 .8 33700	238 42 198 1.0 33800	274 48 200 1.2 33900	300 52 202 1.3 33900	
50				85 15 198 .4 32700	210 38 200 1.0 32900	255 45 202 1.2 33000	286 50 204 1.3 33100	309 54 206 1.3 33100	
52				163 29 202 .8 32000	232 41 204 1.1 32200	269 48 206 1.3 32200	296 52 208 1.3 32300	318 55 210 1.4 32300	
54			21 4 204 .1 30900	197 35 206 1.0 31300	249 44 208 1.2 31400	280 49 210 1.4 31400	305 53 212 1.4 31500	326 56 214 1.5 31500	
56			138 25 208 .7 30400	221 39 210 1.1 30600	262 46 212 1.3 30600	292 51 214 1.4 30700	314 54 216 1.5 30700	332 57 218 1.6 30700	
58			182 33 212 1.0 29700	241 43 214 1.3 29800	276 48 216 1.4 29900	301 52 218 1.5 29900	320 55 220 1.6 30000	339 58 222 1.6 30000	
60		194 35 214 1.1 28100	276 50 216 1.5 28600	314 56 218 1.7 28800	340 60 220 1.8 28900	361 63 222 1.9 28900	376 65 224 1.9 29000	392 67 226 2.0 29000	
62	82 16 214 .5 24800	320 59 218 1.9 26500	373 68 220 2.1 26900	406 73 222 2.3 27100	429 76 224 2.4 27200	447 79 226 2.4 27300	464 81 228 2.5 27300	478 83 230 2.5 27400	
64	178 34 218 1.1 24100	375 70 222 2.2 24700	446 82 224 2.6 24900	487 89 226 2.8 25000	508 92 228 2.9 25200	526 95 230 2.9 25300	541 97 232 3.0 25300	554 98 234 3.0 25400	
66	229 44 222 1.4 23200	359 67 226 2.2 23600	404 74 228 2.4 23700	436 79 230 2.5 23800	459 83 232 2.6 23800	481 86 234 2.7 23900	498 89 236 2.8 23900	513 91 238 2.8 23900	
68	265 50 226 1.7 22300	364 68 230 2.2 22600	401 74 232 2.4 22700	429 78 234 2.5 22700	452 82 236 2.6 22800	471 84 238 2.7 22800	486 87 240 2.8 22800		
70	242 46 230 1.6 21600	336 62 234 2.1 21700	371 68 236 2.3 21800	402 73 238 2.4 21800	425 77 240 2.5 21800	447 80 242 2.6 21800	465 82 244 2.7 21900		
72	239 45 234 1.6 21100	312 57 238 2.0 21200	343 62 240 2.1 21200	368 66 242 2.2 21300	389 69 244 2.3 21300	406 72 246 2.4 21300	421 74 248 2.4 21300		
74	246 46 238 1.6 20600	310 56 242 2.0 20700	337 61 244 2.1 20700	359 64 246 2.2 20700	378 67 248 2.3 20800	395 69 250 2.4 20800			
CORRECTIONS			DISTANCE		TIME	FUEL	LEVEL OFF		
ENGINE ANTI ICE ON			+ 17 %		+ 12 %	+ 20 %	- 600 ft		
TOTAL ANTI ICE ON			+ 25 %		+ 20 %	+ 28 %	- 1600 ft		

IAE Eng. : V2527M

Mod : 20268 + 28238
11.2-08F0A319-133 IAE V2527M-A5 23500010C6KG330 0 018590
0 0 3 0 .0 .00 0 02 1.000 1.000 0 CL-NO-04-006-225

ONE ENGINE OUT MAX ALTITUDE

GROSS CEILING at LONG RANGE and GREEN DOT SPEEDS
Pack Flow Hi – Anti ice OFF

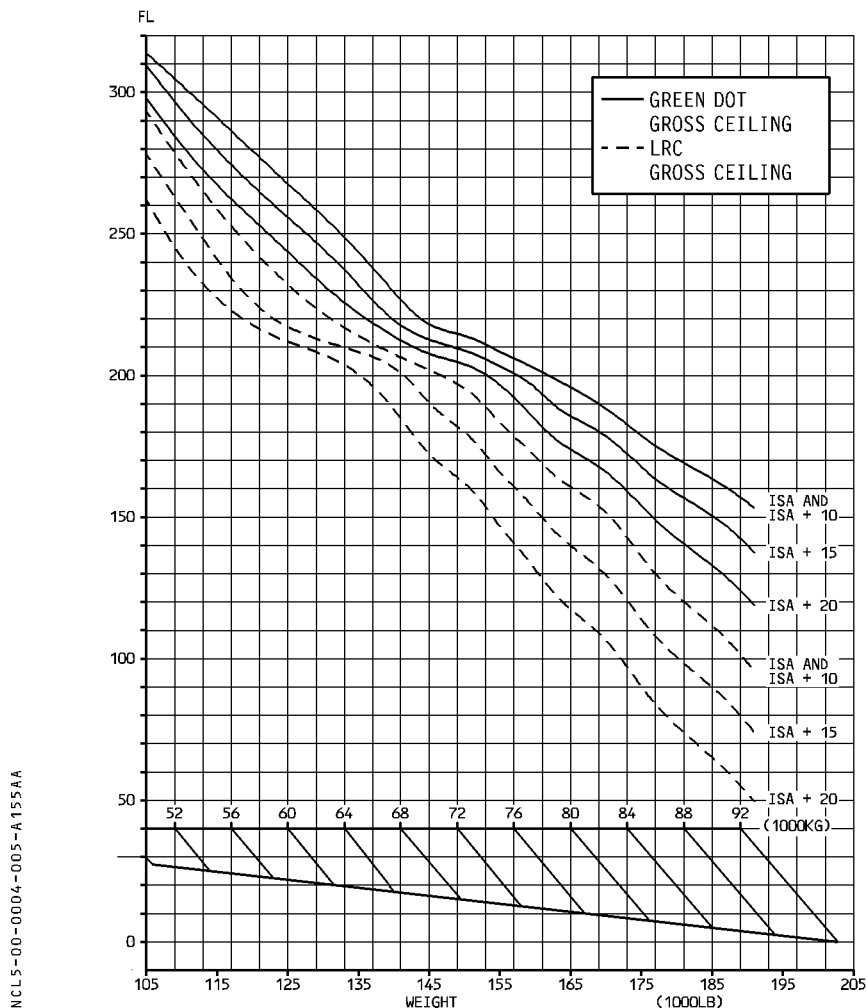

CORRECTIONS

		ISA	ISA + 10	ISA + 15	ISA + 20
LONG RANGE	ENGINE ANTI ICE ON	- 1300 FT	- 1300 FT	- 1400 FT	- 1400 FT
	TOTAL ANTI ICE ON	- 2800 FT	- 2800 FT	- 2800 FT	- 3000 FT
GREEN DOT	ENGINE ANTI ICE ON	- 1000 FT	- 1000 FT	- 1100 FT	- 1200 FT
	TOTAL ANTI ICE ON	- 2100 FT	- 2100 FT	- 2300 FT	- 2500 FT

R NOTE: For weights above 85000 KG or 187400 LB, one engine ceilings at Long Range speed may
R be overestimated by FMS Legacy. In this case, ceiling values provided in the above graph
R should be retained.

ONE ENGINE OUT

GROSS FLIGHT PATH DESCENT AT GREEN DOT SPEED - 1 ENGINE OUT

R	MAX. CONTINUOUS THRUST		ISA		DISTANCE (NM)		TIME (MIN)	
	NORMAL AIR CONDITIONING		CG=33.0%		INITIAL SPEED (KT)		FUEL(1000KG)	
	ANTI-ICING OFF				LEVEL OFF (FT)			
INIT. GW (1000KG)	INITIAL FLIGHT LEVEL							
	250	290	310	330	350	370	390	
50				174 32 198 .9 31700	228 42 200 1.1 31800	262 47 202 1.3 31900	288 52 204 1.5 31900	
54			156 29 202 .9 30100	222 41 204 1.2 30200	258 47 206 1.4 30300	285 52 208 1.5 30300	308 55 210 1.5 30400	
58		152 29 206 .9 28200	231 43 208 1.3 28500	269 50 210 1.5 28600	298 54 212 1.7 28600	320 58 214 1.7 28700	339 61 216 1.8 28700	
62		236 45 212 1.5 26400	279 52 214 1.7 26600	309 57 216 1.8 26600	333 61 218 1.9 26700	352 64 220 2.0 26700	369 67 222 2.1 26800	
66	155 30 214 1.1 24200	281 53 218 1.8 24600	314 59 220 2.0 24600	339 63 222 2.1 24700	360 67 224 2.2 24700	378 69 226 2.3 24800	393 71 228 2.3 24800	
70	231 45 220 1.7 22600	311 59 224 2.1 22800	335 63 226 2.2 22800	357 67 228 2.3 22900	376 70 230 2.4 22900	392 72 232 2.5 22900	406 74 234 2.5 23000	
74	214 41 226 1.6 21300	278 53 230 2.0 21400	301 56 232 2.1 21400	321 60 234 2.2 21500	339 62 236 2.2 21500	354 65 238 2.3 21500		
78	212 40 232 1.6 20500	264 49 236 1.9 20600	283 52 238 2.0 20600	301 55 240 2.1 20600	316 57 242 2.2 20600	330 60 244 2.2 20600		
82	242 46 238 1.9 19600	282 52 242 2.1 19700	298 55 244 2.2 19700	313 57 246 2.3 19700	326 59 248 2.3 19800			
86	278 52 244 2.3 18400	317 58 248 2.5 18400	332 61 250 2.6 18500	346 63 252 2.6 18500	359 65 254 2.7 18500			
90	300 56 250 2.6 17100	335 61 254 2.7 17200	349 64 256 2.8 17200	363 66 258 2.9 17200				
94	317 59 256 2.8 15900	350 64 260 3.0 15900	363 66 262 3.0 16000	375 67 264 3.1 16000				
CORRECTIONS		DISTANCE		TIME	FUEL	LEVEL OFF		
ENGINE ANTI ICE ON		+ 15 %		+ 12 %	+ 18 %	- 200 FT		
TOTAL ANTI ICE ON		+ 20 %		+ 24 %	+ 33 %	- 700 FT		

R

ONE ENGINE OUT

LONG RANGE CRUISE - 1 ENGINE OUT						
MAX. CONTINUOUS THRUST LIMITS PACK FLOW HI ANTI-ICING OFF			ISA CG=33.0%	EPR FUEL FLOW (KG/H)	MACH IAS (KT)	
WEIGHT (1000KG)	FL100	FL150	FL190	FL210	FL230	FL250
50	1.151 .430	1.236 .511	1.267 .515	1.316 .550	1.344 .556	1.393 .584
	1811 237	1968 258	1792 240	1841 247	1777 239	1801 241
52	1.158 .435	1.240 .511	1.292 .535	1.327 .553	1.363 .567	1.412 .594
	1879 240	1987 257	1907 250	1881 248	1855 244	1874 246
54	1.170 .447	1.245 .510	1.312 .550	1.338 .555	1.385 .581	1.431 .602
	1983 247	2011 257	1999 256	1925 249	1947 251	1942 249
56	1.183 .461	1.250 .510	1.323 .553	1.355 .565	1.404 .592	1.440 .600
	2098 255	2040 257	2044 258	2001 253	2024 255	1963 248
58	1.226 .510	1.260 .514	1.333 .555	1.374 .576	1.417 .595	1.444 .585
	2373 283	2095 259	2086 259	2086 259	2071 257	1952 242
60	1.233 .514	1.270 .519	1.346 .561	1.394 .588	1.420 .585	1.452 .562
	2415 285	2156 261	2145 262	2174 264	2065 252	1935 232
62	1.236 .514	1.294 .540	1.362 .570	1.410 .596	1.426 .570	
	2434 285	2287 272	2225 266	2248 268	2055 246	
64	1.239 .513	1.311 .552	1.381 .582	1.418 .595	1.435 .544	
	2454 284	2382 279	2317 272	2272 267	2037 234	
66	1.243 .513	1.322 .556	1.397 .591	1.421 .585		
	2476 284	2432 281	2399 277	2264 263		
68	1.247 .512	1.330 .558	1.412 .599	1.426 .570		
	2499 283	2472 282	2473 280	2253 256		
70	1.254 .514	1.338 .560	1.426 .604	1.436 .543		
	2550 285	2516 283	2537 283	2232 243		
72	1.262 .517	1.351 .567	1.428 .598			
	2604 287	2592 286	2533 280			
74	1.270 .521	1.365 .575	1.432 .587			
	2666 289	2673 290	2523 274			
76	1.290 .539	1.381 .585	1.438 .571			
	2805 299	2767 296	2509 267			
78	1.308 .554	1.395 .593	1.450 .537			
	2927 307	2850 300	2478 250			
ENGINE ANTI ICE ON △FUEL = + 2.5 %				TOTAL ANTI ICE ON △FUEL = + 6 %		

ONE ENGINE OUT

IN CRUISE QUICK CHECK FROM ANY MOMENT IN CRUISE TO LANDING - 1 ENGINE OUT
 CRUISE : LONG RANGE - DESCENT : M.78/300KT/250KT - IMC PROCEDURE : 120 KG (6 MIN)

REF. INITIAL WEIGHT = 55000 KG PACK FLOW HI ANTI-ICING OFF		ISA CG = 33.0 %					FUEL CONSUMED (KG)			
							TIME (H.MIN)			
AIR	FLIGHT LEVEL						CORRECTION ON FUEL CONSUMPTION (KG/1000KG)			
DIST.							FL100	FL200	FL240	
(NM)	100	150	200	220	240	250	FL150	FL220	FL250	
200	1410 0.47	1187 0.44	1049 0.42	999 0.41	954 0.40	931 0.40	9	5	4	
300	2101 1.09	1816 1.03	1627 1.00	1559 0.59	1499 0.57	1469 0.57	15	11	10	
400	2785 1.30	2442 1.22	2203 1.17	2116 1.16	2042 1.14	2004 1.13	20	16	15	
500	3463 1.52	3066 1.40	2776 1.35	2669 1.34	2581 1.31	2535 1.30	26	22	20	
600	4136 2.14	3688 1.59	3346 1.53	3219 1.52	3118 1.48	3063 1.47	31	28	26	
700	4801 2.36	4307 2.18	3913 2.11	3766 2.09	3652 2.05	3588 2.04	37	33	31	
800	5460 2.58	4924 2.37	4477 2.28	4309 2.27	4183 2.22	4110 2.20	42	39	37	
900	6114 3.20	5540 2.55	5040 2.46	4849 2.45	4710 2.39	4629 2.37	47	44	43	
1000	6761 3.43	6153 3.14	5600 3.04	5386 3.03	5233 2.56	5146 2.54	51	49	48	
1100	7403 4.05	6764 3.33	6157 3.22	5920 3.21	5753 3.14	5660 3.11	56	55	54	
1200	8046 4.28	7373 3.52	6712 3.40	6451 3.39	6269 3.31	6173 3.28	61	60	60	
1300	8686 4.49	7980 4.10	7265 3.58	6979 3.57	6783 3.49	6682 3.45	65	65	66	
1400	9323 5.11	8586 4.29	7812 4.17	7504 4.15	7293 4.07	7189 4.02	70	70	72	
ENGINE ANTI ICE ON △FUEL = + 3 %					TOTAL ANTI ICE ON △FUEL = + 6 %					

ONE ENGINE OUT

LONG RANGE CRUISE - 1 ENGINE OUT						
MAX. CONTINUOUS THRUST LIMITS PACK FLOW HI ANTI-ICING OFF			ISA CG=33.0%	EPR FUEL FLOW (KG/H)	MACH IAS (KT)	
WEIGHT (1000KG)	FL100	FL150	FL190	FL210	FL230	FL250
48	1.156 .455 1901 251	1.193 .473 1737 238	1.250 .511 1713 238	1.278 .524 1678 234	1.317 .546 1678 234	1.354 .560 1656 231
50	1.163 .459 1948 254	1.204 .482 1802 242	1.261 .516 1761 240	1.296 .535 1753 240	1.333 .552 1738 237	1.375 .569 1727 235
52	1.169 .463 1992 256	1.221 .495 1890 249	1.275 .525 1827 244	1.314 .545 1825 244	1.350 .559 1799 240	1.397 .580 1807 240
54	1.175 .466 2033 258	1.236 .507 1970 256	1.291 .534 1899 249	1.329 .552 1888 247	1.367 .567 1869 244	1.418 .590 1883 244
56	1.182 .469 2075 260	1.246 .513 2024 258	1.307 .543 1969 253	1.343 .557 1945 250	1.388 .577 1950 249	1.438 .599 1958 248
58	1.188 .472 2115 261	1.254 .515 2062 259	1.322 .551 2037 257	1.359 .564 2013 253	1.408 .587 2027 253	1.443 .589 1955 244
60	1.196 .477 2171 264	1.265 .521 2123 263	1.335 .556 2094 259	1.376 .573 2087 257	1.419 .588 2066 253	1.449 .571 1942 236
62	1.207 .487 2251 270	1.277 .528 2190 266	1.349 .561 2156 262	1.395 .582 2168 261	1.423 .576 2059 248	
64	1.222 .499 2342 276	1.291 .537 2264 271	1.364 .568 2226 265	1.413 .590 2245 265	1.430 .559 2048 240	
66	1.235 .510 2430 283	1.304 .544 2332 274	1.381 .576 2305 269	1.420 .588 2266 264		
68	1.243 .515 2485 285	1.318 .551 2405 278	1.398 .585 2388 274	1.424 .576 2258 259		
70	1.250 .518 2530 287	1.329 .556 2464 281	1.414 .593 2465 277	1.430 .560 2245 251		
72	1.257 .520 2573 288	1.339 .560 2521 283	1.428 .598 2533 280			
74	1.266 .525 2637 291	1.351 .565 2587 285	1.431 .590 2526 276			
ENGINE ANTI ICE ON Δ FUEL = + 2.5 %				TOTAL ANTI ICE ON Δ FUEL = + 4.5 %		

11.2-08F0A319-133 IAE V2527M-A5 12200010C6KG330 0 018590 0 0 3 1.0 .0 .00 0 01 .990 .000 .000 0

CL-N0-04-007-XXX

ONE ENGINE OUT

IN CRUISE QUICK CHECK FROM ANY MOMENT IN CRUISE TO LANDING - 1 ENGINE OUT
CRUISE : LONG RANGE - DESCENT : M.78/300KT/250KT - IMC PROCEDURE : 110 KG (6MIN)

REF. INITIAL WEIGHT = 55000 KG PACK FLOW HI ANTI-ICING OFF		ISA CG = 33.0 %					FUEL CONSUMED (KG)			
							TIME (H.MIN)			
AIR							CORRECTION ON FUEL CONSUMPTION (KG/1000KG)			
DIST.	FLIGHT LEVEL						FL100	FL200	FL240	
(NM)	100	150	200	220	240	250	FL150	FL220	FL250	
200	1377 0.46	1165 0.44	1026 0.42	978 0.42	936 0.41	916 0.41	7	6	5	
300	2059 1.06	1785 1.03	1594 1.00	1530 0.59	1475 0.58	1449 0.57	11	12	11	
400	2737 1.26	2401 1.22	2159 1.18	2079 1.17	2010 1.15	1977 1.14	16	18	17	
500	3413 1.47	3014 1.41	2721 1.37	2624 1.35	2542 1.33	2503 1.31	21	24	23	
600	4085 2.07	3624 2.01	3279 1.55	3166 1.53	3070 1.50	3024 1.49	26	29	29	
700	4754 2.28	4231 2.20	3835 2.13	3705 2.11	3595 2.08	3543 2.06	31	35	35	
800	5420 2.48	4834 2.40	4387 2.32	4240 2.29	4117 2.25	4058 2.23	36	41	41	
900	6082 3.09	5434 2.59	4936 2.50	4773 2.46	4636 2.43	4570 2.40	41	46	48	
1000	6741 3.29	6031 3.19	5481 3.09	5302 3.05	5151 3.00	5079 2.58	45	52	54	
1100	7397 3.50	6625 3.40	6023 3.27	5829 3.23	5662 3.18	5586 3.15	50	57	60	
1200	8051 4.11	7215 4.00	6562 3.46	6353 3.41	6171 3.36	6089 3.33	55	63	66	
1300	8703 4.31	7801 4.20	7098 4.05	6874 3.59	6677 3.54	6590 3.51	60	68	72	
1400	9353 4.52	8383 4.41	7632 4.24	7392 4.17	7180 4.12	7087 4.08	64	74	78	
ENGINE ANTI ICE ON △FUEL = + 2.5 %					TOTAL ANTI ICE ON △FUEL = + 4.5 %					

FLIP23D A319-133 IAE V2527M-A5 3610 03301.001011 0300250.7801.00100 110 0300350 550 100100 35100 18590 CL-N0-04-08-XXX

ONE ENGINE OUT

LONG RANGE CRUISE - 1 ENGINE OUT						
MAX. CONTINUOUS THRUST LIMITS NORMAL AIR CONDITIONING ANTI-ICING OFF			ISA CG=33.0%	EPR FUEL FLOW (KG/H)	MACH IAS (KT)	
WEIGHT (1000KG)	FL100	FL150	FL190	FL210	FL230	FL250
50	1.181 .442	1.250 .480	1.319 .507	1.369 .530	1.417 .549	1.472 .571
	1972 244	1915 241	1856 236	1874 237	1870 236	1875 236
54	1.199 .454	1.281 .494	1.363 .529	1.411 .548	1.464 .569	1.520 .588
	2093 251	2047 249	2029 246	2028 246	2032 245	2034 243
58	1.223 .466	1.310 .506	1.402 .546	1.454 .567	1.510 .587	1.554 .591
	2224 258	2174 255	2185 255	2190 254	2196 253	2138 244
62	1.253 .484	1.344 .521	1.441 .562	1.497 .583	1.536 .585	1.568 .551
	2387 268	2330 263	2343 262	2354 262	2277 252	2121 227
66	1.278 .495	1.380 .538	1.480 .578	1.534 .595	1.548 .548	
	2519 274	2499 272	2504 270	2503 267	2252 235	
70	1.303 .506	1.412 .552	1.517 .591	1.547 .578		
	2651 280	2651 278	2667 277	2519 260		
74	1.327 .515	1.446 .567	1.549 .600	1.562 .528		
	2785 286	2818 286	2811 281	2482 236		
78	1.359 .531	1.478 .579	1.557 .577			
	2968 295	2979 293	2795 270			
82	1.385 .543	1.510 .592	1.574 .523			
	3124 301	3146 299	2758 243			
86	1.412 .554	1.519 .580				
	3282 308	3163 293				
90	1.440 .567	1.529 .559				
	3449 315	3158 282				
94	1.456 .569	1.549 .512				
	3540 316	3139 258				
ENGINE ANTI ICE ON Δ FUEL = + 2 %				TOTAL ANTI ICE ON Δ FUEL = + 4 %		

ONE ENGINE OUT

IN CRUISE QUICK CHECK FROM ANY MOMENT IN CRUISE TO LANDING - 1 ENGINE OUT
CRUISE : LONG RANGE - DESCENT : M.78/300KT/250KT - IMC PROCEDURE : 140 KG (6MIN)

R	REF. INITIAL WEIGHT = 60000 KG		ISA				FUEL CONSUMED (KG)		
	NORMAL AIR CONDITIONING		CG = 33.0 %				TIME (H.MIN)		
AIR	FLIGHT LEVEL						CORRECTION ON FUEL CONSUMPTION (KG/1000KG)		
DIST.							FL100	FL200	FL240
(NM)	100	150	200	220	240	250	FL150	FL220	FL250
200	1510 0.46	1317 0.44	1180 0.42	1131 0.41	1083 0.41	1061 0.41	9	7	6
300	2259 1.06	2008 1.03	1826 0.59	1762 0.58	1699 0.57	1670 0.58	15	14	13
400	3004 1.27	2694 1.22	2468 1.17	2388 1.15	2312 1.14	2276 1.15	21	20	20
500	3745 1.47	3377 1.41	3106 1.34	3010 1.32	2921 1.31	2877 1.32	27	27	27
600	4481 2.08	4055 2.00	3739 1.52	3628 1.49	3527 1.48	3475 1.49	34	34	34
700	5212 2.28	4729 2.19	4369 2.10	4241 2.07	4129 2.04	4069 2.05	40	40	41
800	5938 2.49	5400 2.39	4994 2.28	4851 2.24	4727 2.21	4659 2.22	46	47	48
900	6659 3.10	6066 2.58	5615 2.46	5456 2.41	5320 2.38	5247 2.38	52	53	54
1000	7376 3.31	6728 3.17	6232 3.04	6058 2.59	5907 2.55	5831 2.55	58	60	61
1100	8088 3.52	7387 3.37	6845 3.22	6656 3.16	6490 3.12	6413 3.11	63	66	68
1200	8798 4.13	8042 3.56	7454 3.41	7250 3.34	7070 3.29	6991 3.28	69	73	74
1300	9506 4.34	8693 4.16	8059 3.59	7840 3.52	7645 3.46	7566 3.44	75	79	81
1400	10209 4.55	9340 4.36	8661 4.17	8427 4.10	8217 4.03	8137 4.00	81	86	87
ENGINE ANTI ICE ON Δ FUEL = + 2 %					TOTAL ANTI ICE ON Δ FUEL = + 4 %				

FLIP23 A321-131 IAE V2530-A5 3610 03301.001011 0250300 .7801 .000100 140 0300350 60 0 100100 40100 18590 CL-N0-04-07-150

ALL ENG MAX/OPT ALTITUDES

R

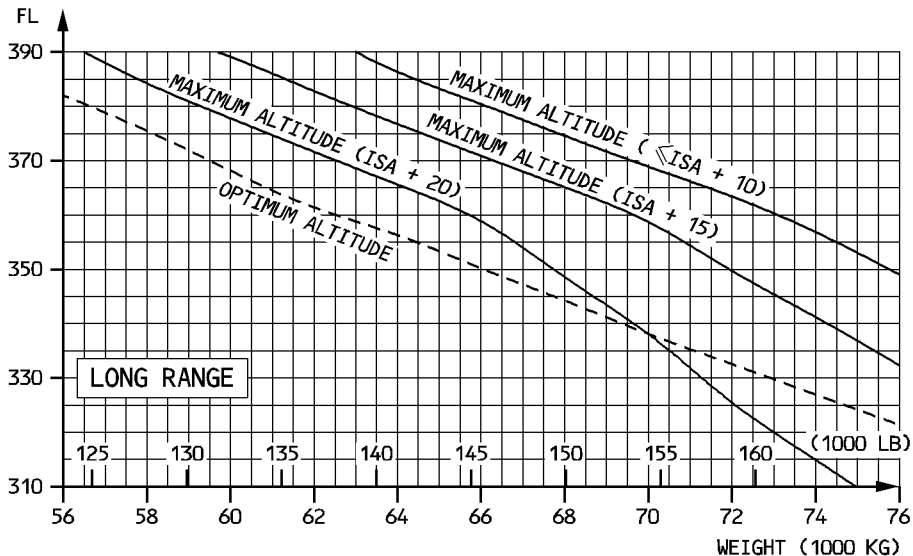
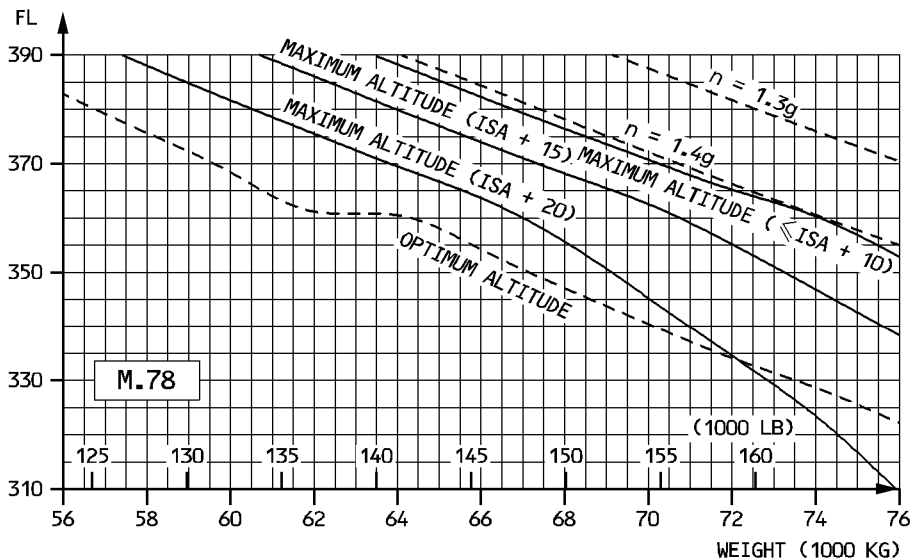

NCL5-00-0004-009-A140AA

CORRECTIONS	ENGINE ANTI ICE	TOTAL ANTI ICE
≤ ISA + 10	Max Alt : - 900 FT Opt Alt : No corr.	Max Alt : - 1700 FT Opt Alt : No corr.
ISA + 15	Max Alt : - 1400 FT Opt Alt : No corr.	Max Alt : - 2800 FT Opt Alt : - 1400 FT
ISA + 20	Max Alt : - 1700 FT Opt Alt : - 1500 FT	Max Alt : - 2800 FT Opt Alt : - 2000 FT

T or L

IAE Eng. : V2527/N2527E

Mod : 20268

ALL ENGINES

IN CRUISE QUICK CHECK FROM ANY MOMENT IN CRUISE TO LANDING

CRUISE : M.78 - DESCENT : M.78/300KT/250KT - IMC PROCEDURE : 120 KG (6MIN)

REF. INITIAL WEIGHT = 60000 KG NORMAL AIR CONDITIONING ANTI-ICING OFF		ISA CG = 33.0 %					FUEL CONSUMED (KG)			
							TIME (H.MIN)			
AIR							CORRECTION ON FUEL CONSUMPTION (KG/1000KG)			
DIST.	FLIGHT LEVEL									
(NM)	290	310	330	350	370	390	FL290 FL310	FL330 FL350	FL370 FL390	
200	933 0.36	879 0.36	834 0.36	792 0.36	757 0.36	739 0.36	0	1	3	
400	2069 1.02	1951 1.02	1858 1.03	1774 1.03	1704 1.03	1692 1.03	5	9	20	
600	3202 1.28	3016 1.28	2873 1.29	2748 1.30	2642 1.30	2628 1.30	9	17	33	
800	4331 1.54	4074 1.55	3881 1.55	3714 1.56	3572 1.57	3550 1.57	13	24	45	
1000	5456 2.20	5124 2.21	4881 2.22	4673 2.23	4492 2.23	4458 2.23	17	32	57	
1200	6579 2.46	6168 2.47	5874 2.48	5624 2.50	5403 2.50	5352 2.50	20	39	67	
1400	7699 3.12	7206 3.13	6859 3.15	6569 3.16	6306 3.17	6232 3.17	23	46	77	
1600	8817 3.37	8245 3.39	7838 3.41	7505 3.43	7202 3.44	7101 3.44	26	53	87	
1800	9932 4.03	9279 4.05	8812 4.07	8432 4.09	8093 4.11	7957 4.11	28	59	95	
2000	11044 4.29	10308 4.32	9778 4.34	9353 4.36	8978 4.37	8803 4.37	30	65	103	
2200	12154 4.55	11332 4.58	10738 5.00	10266 5.03	9855 5.04	9637 5.04	31	71	110	
2400	13262 5.21	12355 5.24	11692 5.27	11173 5.29	10726 5.31	10460 5.31	33	77	117	
2600	14367 5.47	13380 5.50	12640 5.53	12072 5.56	11590 5.58	11274 5.58	34	83	123	
2800	15469 6.13	14403 6.16	13582 6.19	12966 6.23	12448 6.25	12078 6.25	35	87	130	
3000	16570 6.39	15422 6.42	14519 6.46	13853 6.49	13300 6.51	12888 6.51	36	92	136	
LOW AIR CONDITIONING △FUEL = - 0.4 %		ENGINE ANTI ICE ON △FUEL = + 3 %					TOTAL ANTI ICE ON △FUEL = + 5.5 %			

PROGRAM : FLIP23C 17.07.97 ; AERO : A320-232 01/08/97 ; MOTO : A320-233 15/10/97 ; GENE : A320-232 01/10/97 END OF FLIP CL-NO-04-10-140

ALL ENG MAX/OPT ALTITUDES

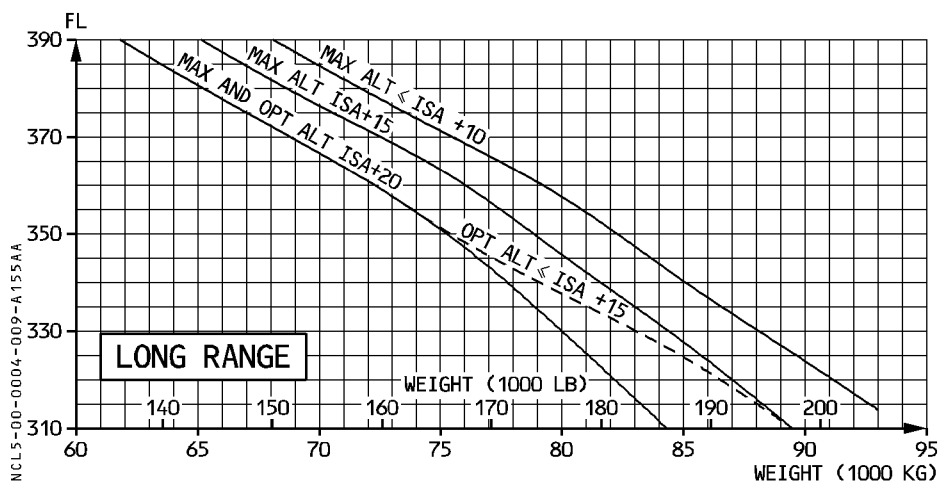
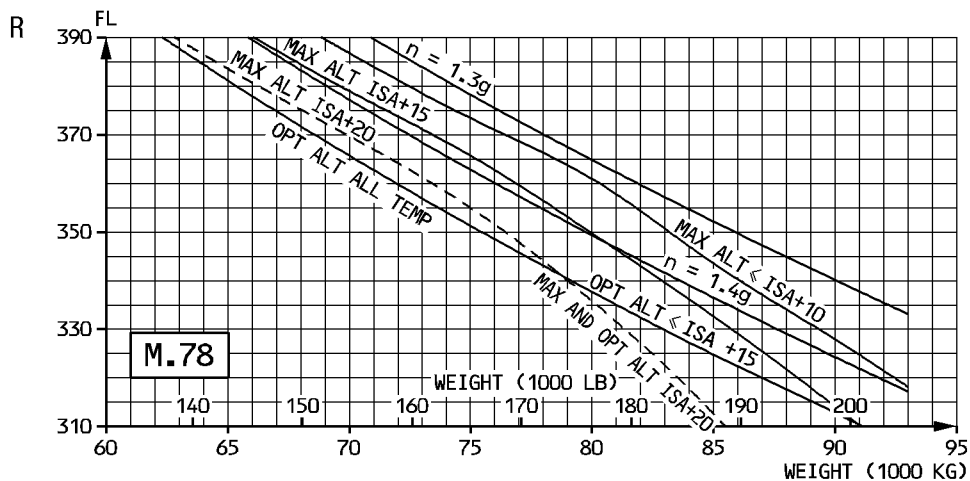

CORRECTIONS	ENGINE ANTI ICE	TOTAL ANTI ICE
\leq ISA + 10	Max Alt : - 500 FT Opt Alt : - 300 FT	Max Alt : - 1100 FT Opt Alt : - 300 FT
ISA + 15	Max Alt : - 700 FT Opt Alt : - 300 FT	Max Alt : - 1500 FT Opt Alt : - 600 FT
ISA + 20	Max Alt : - 1000 FT Opt Alt : - 1000 FT	Max Alt : - 2300 FT Opt Alt : - 2300 FT

ALL ENGINES

IN CRUISE QUICK CHECK FROM ANY MOMENT IN CRUISE TO LANDING
CRUISE : M.78 – DESCENT : M.78/300KT/250KT - IMC PROCEDURE : 140 KG (6MIN)

REF. INITIAL WEIGHT = 65000 KG NORMAL AIR CONDITIONING ANTI-ICING OFF		ISA CG = 33.0 %					FUEL CONSUMED (KG)		
							TIME (H.MIN)		
AIR DIST. (NM)	FLIGHT LEVEL						CORRECTION ON FUEL CONSUMPTION (KG/1000KG)		
	290	310	330	350	370	390	FL290 FL310	FL330 FL350	FL370 FL390
200	1037 0.36	978 0.36	926 0.36	880 0.36	842 0.36	816 0.36	1	2	4
400	2281 1.02	2158 1.02	2049 1.02	1956 1.03	1885 1.03	1854 1.03	7	10	20
600	3518 1.27	3329 1.28	3164 1.29	3023 1.29	2918 1.30	2875 1.30	13	18	33
800	4747 1.53	4494 1.54	4271 1.55	4081 1.56	3939 1.56	3882 1.56	19	25	45
1000	5970 2.19	5650 2.20	5370 2.22	5131 2.23	4951 2.23	4874 2.23	25	33	57
1200	7185 2.45	6799 2.47	6461 2.48	6171 2.49	5952 2.50	5852 2.50	31	40	67
1400	8393 3.11	7941 3.13	7544 3.14	7204 3.16	6944 3.17	6816 3.17	36	47	77
1600	9596 3.37	9076 3.39	8620 3.41	8228 3.43	7925 3.44	7768 3.44	41	54	86
1800	10792 4.03	10205 4.05	9689 4.07	9244 4.09	8898 4.10	8707 4.10	46	60	94
2000	11983 4.29	11327 4.31	10751 4.34	10254 4.36	9865 4.37	9640 4.37	51	66	102
2200	13167 4.55	12442 4.58	11806 5.00	11256 5.03	10825 5.04	10566 5.04	56	73	110
2400	14345 5.21	13551 5.24	12855 5.26	12251 5.29	11776 5.31	11482 5.31	61	79	117
2600	15518 5.47	14654 5.50	13897 5.53	13239 5.56	12720 5.58	12388 5.58	65	85	125
2800	16685 6.13	15750 6.16	14932 6.19	14220 6.23	13657 6.24	13286 6.24	68	90	131
3000	17851 6.39	16841 6.42	15961 6.46	15195 6.49	14586 6.51	14175 6.51	72	96	138
ECON AIR CONDITIONING △FUEL = - 0.6 %			ENGINE ANTI ICE ON △FUEL = + 2 %			TOTAL ANTI ICE ON △FUEL = + 5 %			

ALL ENG MAX/OPT ALTITUDES

R

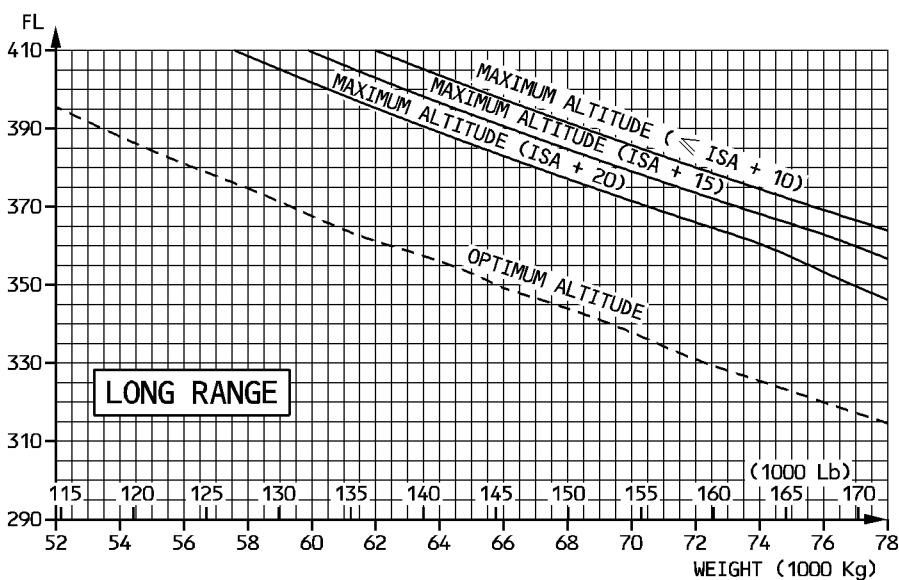
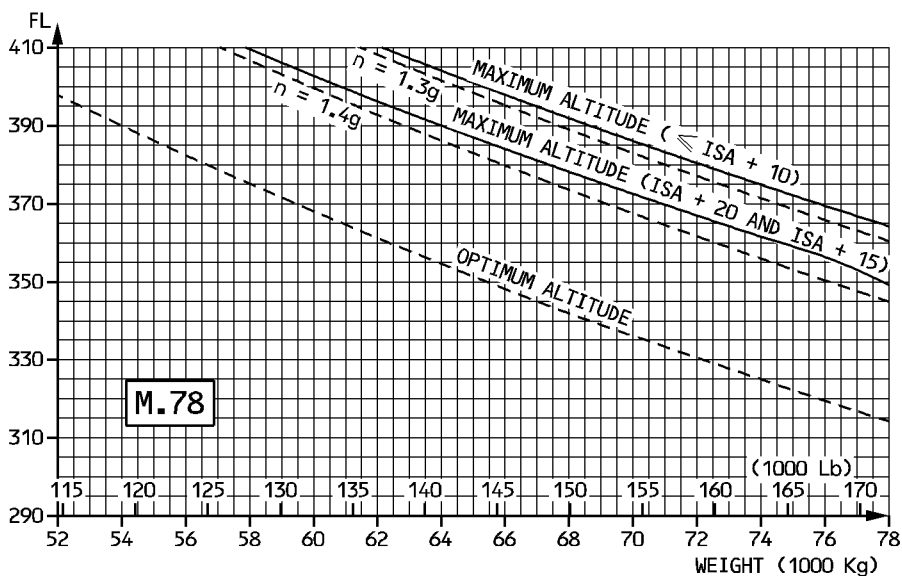

NCL5-00-0004-009-A290AA

T or L

IAE Eng. : V2527M

Mod : 20268 + 28238

	ENGINE ANTI ICE	TOTAL ANTI ICE
ISA	Max Alt.: - 500 FT Opt Alt.: No corr.	Max Alt.: - 1000 FT Opt Alt.: No corr.
ISA + 10	Max Alt.: - 500 FT Opt Alt.: No corr.	Max Alt.: - 1000 FT Opt Alt.: No corr.
ISA + 15	Max Alt.: - 700 FT Opt Alt.: No corr.	Max Alt.: - 1200 FT Opt Alt.: No corr.
ISA + 20	Max Alt.: - 800 FT Opt Alt.: No corr.	Max Alt.: - 1700 FT Opt Alt.: No corr.

ALL ENGINES

IN CRUISE QUICK CHECK FROM ANY MOMENT IN CRUISE TO LANDING

CRUISE : M.78 - DESCENT : M.78/300KT/250KT - IMC PROCEDURE :110 KG (6MIN)

REF. INITIAL WEIGHT = 60000 KG

ISA

FUEL CONSUMED (KG)

NORMAL AIR CONDITIONING

CG = 33.0 %

ANTI-ICING OFF

TIME (H.MIN)

AIR DIST. (NM)	FLIGHT LEVEL						CORRECTION ON FUEL CONSUMPTION (KG/1000KG)		
	310	330	350	370	390	410	FL310 FL330	FL350 FL370	FL390 FL410
200	871 0.36	826 0.36	784 0.36	749 0.36	732 0.36	724 0.36	1	2	5
600	2998 1.28	2856 1.29	2733 1.29	2628 1.30	2619 1.30	2661 1.30	14	22	39
1000	5097 2.21	4856 2.22	4650 2.23	4471 2.23	4444 2.23	4517 2.23	26	39	73
1400	7170 3.13	6825 3.14	6538 3.16	6280 3.17	6214 3.17	6302 3.17	37	55	102
1800	9235 4.05	8769 4.07	8394 4.09	8061 4.11	7932 4.11	8027 4.11	46	69	128
2200	11282 4.58	10687 5.00	10220 5.03	9817 5.04	9603 5.04	9698 5.04	54	82	150
2600	13322 5.50	12580 5.53	12019 5.56	11546 5.58	11231 5.58	11318 5.58	59	95	169
3000	15356 6.42	14451 6.46	13793 6.49	13250 6.51	12838 6.51	12894 6.51	63	107	187
3400	17378 7.35	16300 7.39	15542 7.43	14932 7.45	14434 7.45	14427 7.45	65	119	201
3800	19395 8.27	18141 8.31	17268 8.36	16591 8.38	16002 8.38	15922 8.38	67	131	212
4200	21403 9.19	19980 9.24	18977 9.29	18220 9.32	17548 9.32	17381 9.32	67	141	221
4600	23405 10.12	21803 10.17	20664 10.22	19821 10.25	19090 10.26	18803 10.26	68	149	229
5000	25402 11.04	23639 11.10	22332 11.16	21401 11.19	20610 11.19	20197 11.19	67	157	235
5400	27391 11.56	25475 12.03	23989 12.09	22962 12.13	22111 12.13	21559 12.13	65	164	242
5800	29384 12.49	27302 12.55	25628 13.02	24505 13.06	23595 13.06	22910 13.06	64	168	248
LOW AIR CONDITIONING △FUEL = - 0.6 %			ENGINE ANTI ICE ON △FUEL = + 3.5 %			TOTAL ANTI ICE ON △FUEL = + 6 %			

FLIP23D A319-133 IAE V2527M-A5 3610 03301.000011 0250300 .7800 .00200 110 0300350 60 0 100 20 20 20 18590 CL-NO-04-10-XXX

COST INDEX

For a quick determination of the CILRC, use :

– CILRC = 50 kg/min in the FMGC

or

– CILRC = 70 (100 lb/h) in the FMGC.

ALL ENGINES

DESCENT - M.78/300KT/250KT									
IDLE THRUST		ISA			MAXIMUM CABIN RATE OF DESCENT 350FT/MIN				
NORMAL AIR CONDITIONING		CG=33.0%							
ANTI-ICING OFF									
WEIGHT (1000KG)	60				80				IAS (KT)
	TIME (MIN)	FUEL (KG)	DIST. (NM)	EPR	TIME (MIN)	FUEL (KG)	DIST. (NM)	EPR	
390	16.7	173	100	IDLE					241
370	15.9	166	95	IDLE	18.0	186	108	IDLE	252
350	15.2	159	90	IDLE	17.3	179	103	IDLE	264
330	14.6	153	85	IDLE	16.6	173	98	IDLE	277
310	14.0	148	81	IDLE	16.0	167	93	IDLE	289
290	13.5	143	76	IDLE	15.3	161	88	IDLE	300
270	12.8	137	71	IDLE	14.5	154	81	IDLE	300
250	12.1	131	66	IDLE	13.6	146	75	IDLE	300
240	11.7	127	63	IDLE	13.2	143	72	IDLE	300
220	11.0	121	58	IDLE	12.3	135	66	IDLE	300
200	10.2	114	53	IDLE	11.5	127	60	IDLE	300
180	9.5	108	48	IDLE	10.5	119	54	IDLE	300
160	8.7	100	43	IDLE	9.6	110	48	IDLE	300
140	7.9	93	39	IDLE	8.7	101	42	IDLE	300
120	7.1	85	34	IDLE	7.7	92	37	IDLE	300
100	6.3	76	29	IDLE	6.7	81	31	IDLE	300
50	2.4	30	10	IDLE	2.5	32	11	IDLE	250
15	.0	0	0	IDLE	.0	0	0	IDLE	250
CORRECTIONS		ECON AIR CONDITIONING		ENGINE ANTI ICE ON		TOTAL ANTI ICE ON		PER 1° ABOVE ISA	
TIME		-		+ 1 min		+ 3 min		+ 0.2 %	
FUEL		- 2 %		+ 17 %		+ 90 %		+ 0.7 %	
DISTANCE		-		+ 4 %		+ 20 %		+ 0.4 %	

10B-08FA321-131IAEV2530-A52310000C5KG330001859000-1-350.015.0.00003.780300.000250.0000 FCOM-N0-03-05-30-002-150

COST INDEX

For a quick determination of the CILRC, use :

– CILRC = 40 kg/min in the FMGC

or

– CILRC = 55 (100 lb/h) in the FMGC.

ALL ENGINES

DESCENT - M.78/300KT/250KT									
IDLE THRUST		ISA			MAXIMUM CABIN RATE OF DESCENT 350FT/MIN				
NORMAL AIR CONDITIONING		CG=33.0%							
ANTI-ICING OFF									
WEIGHT (1000KG)	45				65				IAS (KT)
	TIME (MIN)	FUEL (KG)	DIST. (NM)	EPR	TIME (MIN)	FUEL (KG)	DIST. (NM)	EPR	
FL									
390	16.1	188	98	1.047	19.0	192	114	IDLE	241
370	14.6	158	87	1.066	18.2	185	108	IDLE	252
350	13.5	139	78	IDLE	17.5	178	102	IDLE	264
330	12.9	134	74	IDLE	16.8	171	97	IDLE	277
310	12.4	129	71	IDLE	16.1	166	93	IDLE	289
290	12.0	125	67	IDLE	15.5	160	88	IDLE	300
270	11.4	120	63	IDLE	14.7	153	82	IDLE	300
250	10.8	115	58	IDLE	13.9	146	76	IDLE	300
240	10.5	112	56	IDLE	13.5	143	73	IDLE	300
220	9.9	107	52	IDLE	12.7	136	67	IDLE	300
200	9.3	102	48	IDLE	11.8	129	62	IDLE	300
180	8.7	97	44	IDLE	11.0	122	56	IDLE	300
160	8.0	91	40	IDLE	10.1	114	50	IDLE	300
140	7.4	85	36	IDLE	9.2	106	45	IDLE	300
120	6.7	79	32	IDLE	8.3	97	39	IDLE	300
100	6.0	72	28	IDLE	7.4	88	34	IDLE	300
50	2.2	28	10	IDLE	2.7	34	12	IDLE	250
15	.0	0	0	IDLE	.0	0	0	IDLE	250
CORRECTIONS		LOW AIR CONDITIONING		ENGINE ANTI ICE ON		TOTAL ANTI ICE ON		PER 1° ABOVE ISA	
TIME		-		+ 4 %		+ 18 %		+ 0.3 %	
FUEL		- 1 %		+ 17 %		+ 85 %		+ 0.4 %	
DISTANCE		-		+ 4 %		+ 18 %		+ 0.4 %	

10F - 08F0A320 - 233 IAE V2527-EA5 23100000C5KG330 0 018590 0 0 - 1 - 360.0 15.0 .00 0 03 .780300.000250.000 0 CL-NO - 04 - 12 - 140

COST INDEX

For a quick determination of the CILRC, use :

– CILRC = 50 kg/min in the FMGC

or

– CILRC = 70 (100 lb/h) in the FMGC.

ALL ENGINES

R

DESCENT - M.78/300 KT/250KT									
IDLE THRUST			ISA		MAXIMUM CABIN RATE OF DESCENT 350FT/MIN				
NORMAL AIR CONDITIONING			CG=33.0%						
ANTI-ICING OFF									
WEIGHT (1000KG)	45				65				IAS (KT)
	FL	TIME (MIN)	FUEL (KG)	DIST. (NM)	EPR	TIME (MIN)	FUEL (KG)	DIST. (NM)	
410	16.1	174	99	1.023	19.4	195	118	IDLE	230
390	14.7	151	88	1.045	18.6	188	112	IDLE	241
370	13.9	142	82	IDLE	17.8	180	106	IDLE	252
350	13.2	135	77	IDLE	17.1	173	101	IDLE	264
330	12.7	130	73	IDLE	16.4	167	96	IDLE	277
310	12.2	126	69	IDLE	15.8	161	91	IDLE	289
290	11.7	122	66	IDLE	15.1	156	86	IDLE	300
270	11.1	116	61	IDLE	14.3	149	80	IDLE	300
250	10.5	111	57	IDLE	13.5	142	74	IDLE	300
240	10.2	109	55	IDLE	13.1	138	71	IDLE	300
220	9.6	104	51	IDLE	12.3	131	65	IDLE	300
200	9.0	99	47	IDLE	11.4	125	60	IDLE	300
180	8.4	93	42	IDLE	10.6	117	54	IDLE	300
160	7.7	88	38	IDLE	9.7	110	48	IDLE	300
140	7.1	82	34	IDLE	8.8	101	43	IDLE	300
120	6.4	75	30	IDLE	7.9	92	37	IDLE	300
100	5.7	68	26	IDLE	7.0	83	32	IDLE	300
50	2.2	27	9	IDLE	2.6	32	11	IDLE	250
15	.0	0	0	IDLE	.0	0	0	IDLE	250
CORRECTIONS		LOW AIR CONDITIONING		ENGINE ANTI ICE ON		TOTAL ANTI ICE ON		PER 1° ABOVE ISA	
TIME		+ 1 %		+ 6 %		+ 30 %		+ 0.3 %	
FUEL		- 1 %		+ 20 %		+ 95 %		+ 0.5 %	
DISTANCE		+ 2 %		+ 8 %		+ 30 %		+ 0.6 %	

ALL ENGINES

R

ALTERNATE PLANNING FROM DESTINATION TO ALTERNATE AIRPORT
GO-AROUND : 100 KG - CLIMB : 250KT/300KT/M.78 - CRUISE : LONG RANGE
DESCENT : M.78/300KT/250KT - VMC PROCEDURE : 80 KG (4MIN)

REF. LDG WT AT DEST. = 55000 KG NORMAL AIR CONDITIONING ANTI-ICING OFF		ISA CG = 33.0 %		FUEL CONSUMED (KG)						
		TIME (H.MIN)						CORRECTION ON FUEL CONSUMPTION (KG/1000KG)		
AIR	FLIGHT LEVEL									
DIST.							FL100	FL200	FL290	
(NM)	100	150	200	250	290	330	FL150	FL250	FL330	
40	529 0.12						2			
60	681 0.16						4			
80	832 0.20	803 0.20					5			
100	984 0.24	943 0.24	939 0.22				6	5		
120	1136 0.28	1084 0.27	1066 0.26	1072 0.25			7	6		
140	1289 0.32	1224 0.31	1192 0.29	1182 0.28			9	7		
160	1441 0.37	1365 0.35	1319 0.32	1291 0.32	1307 0.31		10	7	9	
180	1594 0.41	1506 0.39	1446 0.35	1401 0.35	1409 0.34	1422 0.33	11	8	11	
200	1747 0.45	1647 0.42	1573 0.38	1511 0.38	1511 0.37	1518 0.36	13	9	12	
220	1900 0.49	1788 0.46	1700 0.42	1621 0.41	1613 0.40	1613 0.39	14	9	13	
240	2054 0.53	1930 0.50	1828 0.45	1731 0.45	1715 0.43	1709 0.42	15	10	14	
260	2207 0.57	2072 0.54	1955 0.48	1841 0.48	1817 0.46	1805 0.45	17	11	15	
280	2361 1.01	2213 0.57	2082 0.51	1951 0.51	1920 0.49	1901 0.48	18	11	16	
300	2515 1.05	2356 1.01	2210 0.54	2061 0.54	2022 0.52	1997 0.51	19	12	17	
320	2669 1.09	2498 1.05	2337 0.58	2172 0.57	2125 0.56	2094 0.53	21	13	18	
340	2823 1.13	2640 1.09	2465 1.01	2282 1.01	2228 0.59	2190 0.56	22	13	19	
360	2978 1.17	2783 1.12	2592 1.04	2393 1.04	2330 1.02	2286 0.59	23	14	20	
380	3133 1.21	2926 1.16	2720 1.07	2503 1.07	2433 1.05	2383 1.02	25	15	21	
400	3288 1.25	3069 1.20	2848 1.10	2614 1.10	2537 1.08	2480 1.05	26	16	22	
420	3443 1.29	3212 1.23	2975 1.14	2725 1.14	2640 1.11	2576 1.08	27	16	23	
440	3598 1.33	3356 1.27	3103 1.17	2835 1.17	2743 1.14	2673 1.11	29	17	25	
460	3754 1.37	3499 1.30	3231 1.20	2946 1.20	2846 1.17	2770 1.13	30	18	26	
480	3909 1.41	3643 1.34	3359 1.23	3057 1.23	2950 1.20	2868 1.16	31	18	27	
500	4065 1.45	3787 1.38	3487 1.26	3169 1.27	3054 1.23	2965 1.19	33	19	28	
LOW AIR CONDITIONING ΔFUEL = - 1 %		ENGINE ANTI ICE ON ΔFUEL = + 3 %				TOTAL ANTI ICE ON ΔFUEL = + 7 %				

CL-NO-04-13-140

IAE Eng. : V2527/N2527E

Mod : 20268
 FLIP23F A320-232 IAE V2527-A5 3520 03301.000010 0250300 .7801 .0
 0000 80 100300300 55 0 100100 40100 18590

FLIGHT WITHOUT CAB PRESS

R

IN CRUISE QUICK CHECK FROM ANY MOMENT IN CRUISE TO LANDING
 CRUISE : LONG RANGE - DESCENT : 250KT
 IMC PROCEDURE : 120 KG (6MIN)

FL100

NORMAL AIR CONDITIONING ANTI-ICING OFF		ISA CG = 25.0%				FUEL CONSUMED (KG) TIME (H.MIN)		
AIR DIST. (NM)	INITIAL WEIGHT (1000KG)							
	50	55	60	65	70	75	80	
40	301 0.15	296 0.15	293 0.15	293 0.15	294 0.15	296 0.15	300 0.15	
60	445 0.19	446 0.19	450 0.19	456 0.19	463 0.18	472 0.18	480 0.18	
80	588 0.23	596 0.23	606 0.23	619 0.22	633 0.22	648 0.21	661 0.21	
100	731 0.28	746 0.27	762 0.27	781 0.26	802 0.25	824 0.25	841 0.24	
120	874 0.32	895 0.31	918 0.31	944 0.30	971 0.29	999 0.28	1021 0.27	
140	1017 0.36	1045 0.35	1074 0.35	1106 0.34	1140 0.33	1174 0.31	1201 0.30	
160	1160 0.41	1194 0.40	1229 0.39	1268 0.38	1309 0.36	1349 0.35	1381 0.34	
180	1302 0.45	1343 0.44	1385 0.43	1430 0.42	1477 0.40	1524 0.38	1560 0.37	
200	1444 0.50	1491 0.48	1540 0.47	1591 0.45	1645 0.44	1699 0.41	1740 0.40	
220	1587 0.54	1640 0.52	1695 0.51	1752 0.49	1813 0.47	1873 0.45	1919 0.43	
240	1728 0.58	1788 0.56	1849 0.55	1914 0.53	1981 0.51	2048 0.48	2098 0.46	
260	1870 1.03	1936 1.00	2004 0.99	2074 0.97	2148 0.95	2222 0.92	2277 0.90	
280	2012 1.07	2084 1.05	2158 1.03	2235 1.01	2316 0.98	2396 0.95	2456 0.93	
300	2153 1.11	2232 1.09	2312 1.07	2396 1.05	2483 1.02	2570 0.99	2634 0.96	
320	2294 1.16	2380 1.13	2466 1.11	2556 1.09	2650 1.06	2743 1.02	2813 0.99	
340	2435 1.20	2527 1.17	2620 1.15	2716 1.12	2816 1.10	2917 1.05	2991 1.02	
360	2576 1.25	2674 1.21	2773 1.19	2876 1.16	2983 1.13	3090 1.09	3169 1.06	
380	2716 1.29	2821 1.26	2927 1.23	3035 1.20	3149 1.17	3263 1.12	3347 1.09	
400	2856 1.33	2968 1.30	3080 1.27	3195 1.24	3315 1.21	3436 1.16	3525 1.12	
420	2997 1.38	3114 1.34	3233 1.31	3354 1.28	3480 1.25	3609 1.19	3702 1.15	
440	3137 1.42	3261 1.38	3385 1.35	3513 1.32	3646 1.28	3781 1.22	3880 1.19	
460	3276 1.47	3407 1.43	3538 1.39	3672 1.36	3811 1.32	3954 1.26	4057 1.22	
480	3416 1.51	3553 1.47	3690 1.43	3830 1.40	3977 1.36	4126 1.29	4235 1.25	
500	3555 1.56	3699 1.51	3842 1.47	3989 1.44	4142 1.40	4298 1.33	4412 1.29	
520	3695 2.00	3844 1.55	3994 1.51	4147 1.48	4306 1.43	4470 1.36	4588 1.32	
540	3834 2.05	3990 2.00	4146 1.55	4305 1.51	4471 1.47	4642 1.40	4765 1.35	
AIR CONDITIONING OFF ΔFUEL = - 1.5 %		ENGINE ANTI ICE ON ΔFUEL = + 3 %				TOTAL ANTI ICE ON ΔFUEL = + 6 %		

ALL ENGINES

R

ALTERNATE PLANNING FROM DESTINATION TO ALTERNATE AIRPORT
GO-AROUND : 80 KG - CLIMB : 250KT/300KT/M.78 - CRUISE : LONG RANGE
DESCENT : M.78/300KT/250KT - VMC PROCEDURE : 60 KG (4MIN)

REF. LDG WT AT DEST. = 50000 KG NORMAL AIR CONDITIONING ANTI-ICING OFF		ISA CG = 33.0 %					FUEL CONSUMED (KG)			
							TIME (H.MIN)			
AIR DIST. (NM)	FLIGHT LEVEL						CORRECTION ON FUEL CONSUMPTION (KG/1000KG)			
	100	150	200	250	290	330	FL100 FL150	FL200 FL250	FL290 FL330	
40	482 0.12						2			
60	634 0.16	606 0.16					3			
80	787 0.20	742 0.20					4			
100	940 0.24	878 0.24	868 0.22				5	5		
120	1093 0.28	1014 0.28	990 0.26	990 0.25			6	6		
140	1247 0.32	1150 0.32	1112 0.29	1096 0.28	1112 0.28		7	7	8	
160	1400 0.36	1287 0.36	1234 0.33	1203 0.31	1208 0.31	1223 0.30	8	8	10	
180	1554 0.40	1423 0.39	1356 0.36	1309 0.35	1304 0.34	1312 0.33	9	8	11	
200	1707 0.44	1560 0.43	1478 0.40	1415 0.38	1400 0.37	1402 0.36	9	9	12	
220	1861 0.49	1697 0.47	1600 0.43	1522 0.41	1497 0.41	1492 0.39	10	10	13	
240	2015 0.53	1834 0.51	1723 0.46	1628 0.44	1593 0.44	1582 0.42	11	10	14	
260	2169 0.57	1971 0.55	1845 0.50	1735 0.48	1690 0.47	1672 0.45	12	11	15	
280	2324 1.01	2108 0.59	1968 0.53	1841 0.51	1786 0.50	1763 0.48	13	12	16	
300	2478 1.05	2246 1.03	2090 0.57	1948 0.54	1883 0.53	1853 0.51	14	12	17	
320	2632 1.09	2384 1.07	2213 1.00	2055 0.57	1980 0.57	1943 0.54	15	13	18	
340	2787 1.13	2521 1.10	2336 1.03	2162 1.01	2077 1.00	2034 0.57	16	14	19	
360	2942 1.17	2659 1.14	2459 1.07	2269 1.04	2174 1.03	2124 1.00	17	15	20	
380	3097 1.21	2797 1.18	2582 1.10	2375 1.07	2271 1.06	2215 1.03	18	15	21	
400	3252 1.25	2936 1.22	2705 1.13	2482 1.10	2368 1.10	2306 1.06	19	16	22	
420	3407 1.29	3074 1.26	2828 1.17	2590 1.13	2465 1.13	2397 1.09	20	17	23	
440	3562 1.33	3213 1.30	2952 1.20	2697 1.17	2563 1.16	2487 1.12	21	17	24	
460	3718 1.37	3351 1.33	3075 1.24	2804 1.20	2660 1.19	2578 1.15	22	18	25	
480	3873 1.41	3490 1.37	3199 1.27	2911 1.23	2758 1.22	2670 1.18	23	19	26	
500	4029 1.45	3629 1.41	3322 1.30	3018 1.26	2855 1.26	2761 1.21	24	19	27	
LOW AIR CONDITIONING △FUEL = - 1 %		ENGINE ANTI ICE ON △FUEL = + 4 %					TOTAL ANTI ICE ON △FUEL = + 8 %			

CL-NO-04-13-145

IAE Eng. : V2527M

Mod : 20268
 FLIP23F A319-133 IAE V2527M-A5 3520 03301.000010 0250300 .7801 .0
 0000 60 80300300 50 0 100100 40100 18590

FLIGHT WITHOUT CAB PRESS

R

IN CRUISE QUICK CHECK FROM ANY MOMENT IN CRUISE TO LANDING
 CRUISE : LONG RANGE - DESCENT : 250KT
 IMC PROCEDURE : 110 KG (6MIN)

FL100

NORMAL AIR CONDITIONING ANTI-ICING OFF		ISA CG = 25.0%				FUEL CONSUMED (KG) TIME (H.MIN)		
AIR DIST. (NM)	INITIAL WEIGHT (1000KG)							
	45	50	55	60	65	70	75	
40	297 0.15	291 0.15	287 0.15	285 0.15	284 0.15	285 0.15	288 0.15	
60	444 0.19	442 0.19	443 0.19	445 0.19	449 0.18	455 0.18	462 0.18	
80	591 0.23	593 0.23	598 0.23	605 0.23	614 0.22	625 0.22	637 0.21	
100	737 0.27	744 0.27	753 0.27	764 0.26	779 0.26	795 0.25	811 0.25	
120	884 0.32	895 0.31	908 0.31	924 0.30	944 0.30	965 0.29	985 0.28	
140	1030 0.36	1046 0.35	1062 0.35	1083 0.34	1109 0.33	1135 0.32	1159 0.31	
160	1177 0.40	1197 0.39	1217 0.39	1242 0.38	1273 0.37	1304 0.35	1333 0.35	
180	1323 0.44	1347 0.43	1372 0.43	1401 0.42	1437 0.41	1473 0.39	1506 0.38	
200	1469 0.48	1497 0.47	1526 0.47	1560 0.46	1601 0.45	1642 0.42	1680 0.41	
220	1615 0.53	1648 0.52	1680 0.51	1719 0.50	1765 0.48	1811 0.46	1853 0.44	
240	1761 0.57	1798 0.56	1834 0.55	1878 0.54	1929 0.52	1980 0.49	2027 0.48	
260	1906 1.01	1948 1.00	1988 0.99	2036 0.98	2092 0.96	2149 0.93	2200 0.91	
280	2052 1.05	2098 1.04	2142 1.03	2194 1.02	2255 1.00	2317 0.96	2373 0.94	
300	2198 1.09	2248 1.08	2296 1.07	2353 1.06	2418 1.04	2486 1.00	2546 0.98	
320	2343 1.14	2397 1.12	2449 1.11	2511 1.10	2581 1.08	2654 1.03	2719 1.01	
340	2488 1.18	2547 1.16	2603 1.15	2669 1.14	2744 1.12	2822 1.07	2892 1.04	
360	2633 1.22	2696 1.20	2756 1.19	2826 1.18	2907 1.15	2990 1.10	3064 1.08	
380	2778 1.26	2846 1.24	2909 1.23	2984 1.22	3069 1.19	3157 1.14	3237 1.11	
400	2923 1.31	2995 1.28	3063 1.27	3141 1.26	3231 1.23	3325 1.17	3409 1.14	
420	3067 1.35	3144 1.33	3216 1.31	3299 1.30	3394 1.27	3493 1.21	3581 1.18	
440	3212 1.39	3293 1.37	3369 1.35	3456 1.33	3556 1.31	3660 1.25	3753 1.21	
460	3356 1.44	3442 1.41	3521 1.39	3613 1.37	3718 1.35	3827 1.28	3925 1.25	
480	3500 1.48	3591 1.45	3674 1.43	3770 1.41	3879 1.38	3994 1.32	4096 1.28	
500	3644 1.52	3739 1.49	3827 1.47	3926 1.45	4041 1.42	4161 1.35	4268 1.31	
520	3788 1.57	3888 1.53	3979 1.51	4083 1.49	4202 1.46	4328 1.39	4439 1.35	
540	3931 2.01	4036 1.57	4132 1.55	4239 1.53	4364 1.50	4494 1.42	4610 1.38	
AIR CONDITIONING OFF ΔFUEL = - 3 %		ENGINE ANTI ICE ON ΔFUEL = + 3 %				TOTAL ANTI ICE ON ΔFUEL = + 6 %		

ALL ENGINES

R

ALTERNATE PLANNING FROM DESTINATION TO ALTERNATE AIRPORT
GO-AROUND : 120 KG - CLIMB : 250KT/300KT/M.78 - CRUISE : LONG RANGE
DESCENT : M.78/300KT/250KT - VMC PROCEDURE : 100 KG (4MIN)

REF. LDG WT AT DEST. = 60000 KG NORMAL AIR CONDITIONING ANTI-ICING OFF		ISA CG = 33.0 %		FUEL CONSUMED (KG)						
AIR		FLIGHT LEVEL						CORRECTION ON FUEL CONSUMPTION (KG/1000KG)		
DIST.							FL100	FL200	FL290	
(NM)	100	150	200	250	290	330	FL150	FL250	FL330	
40	601 0.12						2			
60	775 0.16						4			
80	950 0.20	898 0.19					5			
100	1124 0.23	1056 0.23	1035 0.22				6	6		
120	1299 0.27	1213 0.26	1172 0.26	1172 0.25			7	7		
140	1474 0.31	1371 0.30	1310 0.29	1294 0.28			8	8		
160	1649 0.35	1529 0.33	1447 0.32	1416 0.31	1423 0.31		9	8	10	
180	1825 0.39	1687 0.37	1585 0.35	1539 0.35	1536 0.34	1547 0.33	10	9	12	
200	2000 0.43	1845 0.40	1723 0.38	1662 0.38	1650 0.36	1654 0.36	11	10	13	
220	2176 0.46	2003 0.44	1860 0.42	1784 0.41	1763 0.39	1761 0.39	12	10	14	
240	2352 0.50	2161 0.47	1998 0.45	1907 0.44	1877 0.42	1869 0.41	13	11	15	
260	2529 0.54	2320 0.50	2136 0.48	2030 0.47	1991 0.45	1976 0.44	15	12	16	
280	2705 0.58	2479 0.54	2274 0.51	2153 0.50	2105 0.48	2084 0.47	16	13	17	
300	2882 1.02	2638 0.57	2413 0.54	2277 0.53	2220 0.51	2192 0.50	17	13	18	
320	3059 1.05	2797 1.01	2551 0.58	2400 0.57	2334 0.54	2300 0.53	18	14	20	
340	3236 1.09	2956 1.04	2689 1.01	2524 1.00	2449 0.57	2408 0.55	19	15	21	
360	3414 1.13	3115 1.07	2828 1.04	2647 1.03	2563 1.00	2516 0.58	20	16	22	
380	3591 1.17	3275 1.11	2966 1.07	2771 1.06	2678 1.03	2625 1.01	21	16	23	
400	3769 1.21	3435 1.14	3105 1.10	2895 1.09	2793 1.06	2733 1.04	22	17	24	
420	3947 1.24	3594 1.18	3243 1.14	3019 1.12	2908 1.09	2842 1.06	23	18	25	
440	4125 1.28	3754 1.21	3382 1.17	3143 1.15	3023 1.12	2951 1.09	25	19	26	
460	4304 1.32	3915 1.24	3521 1.20	3267 1.18	3138 1.15	3060 1.12	26	20	27	
480	4482 1.35	4075 1.28	3660 1.23	3392 1.21	3253 1.18	3169 1.15	27	20	28	
500	4661 1.39	4235 1.31	3799 1.26	3516 1.25	3369 1.21	3278 1.18	28	21	30	
LOW AIR CONDITIONING ΔFUEL = - 1 %		ENGINE ANTI ICE ON ΔFUEL = + 4 %				TOTAL ANTI ICE ON ΔFUEL = + 6 %				

CL-NO-04-13-155

IAE Eng. : V2533

Mod : 20268
 FLIP23F A321-131 IAE V2530-A5 3520 03301.000010 0250300 .7801 .0
 0000 100 120300300 60 0 110100 40100 18590

FLIGHT WITHOUT CAB PRESS

R

IN CRUISE QUICK CHECK FROM ANY MOMENT IN CRUISE TO LANDING
 CRUISE : LONG RANGE - DESCENT : 250KT
 IMC PROCEDURE : 140 KG (6MIN)

FL100

NORMAL AIR CONDITIONING ANTI-ICING OFF		ISA CG = 25.0%				FUEL CONSUMED (KG) TIME (H.MIN)	
AIR DIST. (NM)	INITIAL WEIGHT (1000KG)						
	65	70	75	80	85	90	95
40	337 0.15	339 0.15	342 0.15	347 0.15	353 0.15	361 0.15	370 0.15
60	515 0.18	523 0.18	531 0.18	540 0.18	551 0.18	561 0.18	571 0.18
80	693 0.22	706 0.22	719 0.21	733 0.21	748 0.21	761 0.21	773 0.21
100	871 0.26	890 0.25	908 0.25	926 0.24	945 0.24	960 0.24	975 0.24
120	1048 0.30	1073 0.29	1096 0.28	1119 0.28	1141 0.27	1160 0.27	1176 0.27
140	1226 0.33	1256 0.32	1284 0.31	1312 0.31	1338 0.30	1359 0.30	1378 0.30
160	1403 0.37	1438 0.36	1472 0.35	1504 0.34	1534 0.33	1559 0.33	1580 0.33
180	1580 0.41	1621 0.39	1659 0.38	1696 0.37	1731 0.36	1758 0.36	1782 0.36
200	1757 0.45	1803 0.43	1846 0.42	1888 0.41	1927 0.39	1957 0.39	1984 0.39
220	1933 0.48	1985 0.46	2034 0.45	2080 0.44	2123 0.43	2156 0.42	2185 0.42
240	2110 0.52	2167 0.50	2221 0.48	2271 0.47	2319 0.46	2355 0.45	2387 0.45
260	2286 0.56	2349 0.53	2407 0.52	2463 0.51	2515 0.49	2554 0.48	2589 0.48
280	2462 1.00	2530 0.57	2594 0.55	2654 0.54	2710 0.52	2753 0.51	2791 0.51
300	2637 1.04	2711 1.00	2780 0.58	2845 0.57	2906 0.55	2952 0.54	2993 0.54
320	2813 1.07	2892 1.04	2967 1.02	3036 1.00	3101 0.59	3150 0.57	3195 0.57
340	2988 1.11	3073 1.07	3153 1.05	3227 1.04	3296 1.02	3349 1.00	3397 1.00
360	3164 1.15	3254 1.11	3339 1.09	3417 1.07	3491 1.05	3547 1.03	3599 1.03
380	3339 1.19	3434 1.15	3524 1.12	3608 1.10	3686 1.08	3745 1.05	3800 1.05
400	3513 1.23	3615 1.18	3710 1.15	3798 1.14	3881 1.12	3943 1.08	4001 1.08
420	3688 1.26	3795 1.22	3895 1.19	3988 1.17	4076 1.15	4141 1.11	4202 1.11
440	3862 1.30	3975 1.25	4080 1.22	4177 1.20	4270 1.18	4339 1.14	4402 1.14
460	4037 1.34	4154 1.29	4265 1.26	4367 1.24	4465 1.22	4537 1.17	4603 1.17
480	4211 1.38	4334 1.33	4450 1.29	4557 1.27	4659 1.25	4735 1.20	4803 1.20
500	4384 1.42	4513 1.36	4635 1.33	4746 1.30	4853 1.28	4932 1.23	5003 1.23
520	4558 1.46	4692 1.40	4819 1.36	4935 1.34	5047 1.32	5130 1.26	5203 1.26
540	4732 1.49	4871 1.43	5003 1.40	5124 1.37	5241 1.35	5327 1.29	5403 1.29
AIR CONDITIONING OFF ΔFUEL = - 2 %		ENGINE ANTI ICE ON ΔFUEL = + 3 %				TOTAL ANTI ICE ON ΔFUEL = + 5 %	

GROUND DISTANCE - AIR DISTANCE CONVERSION

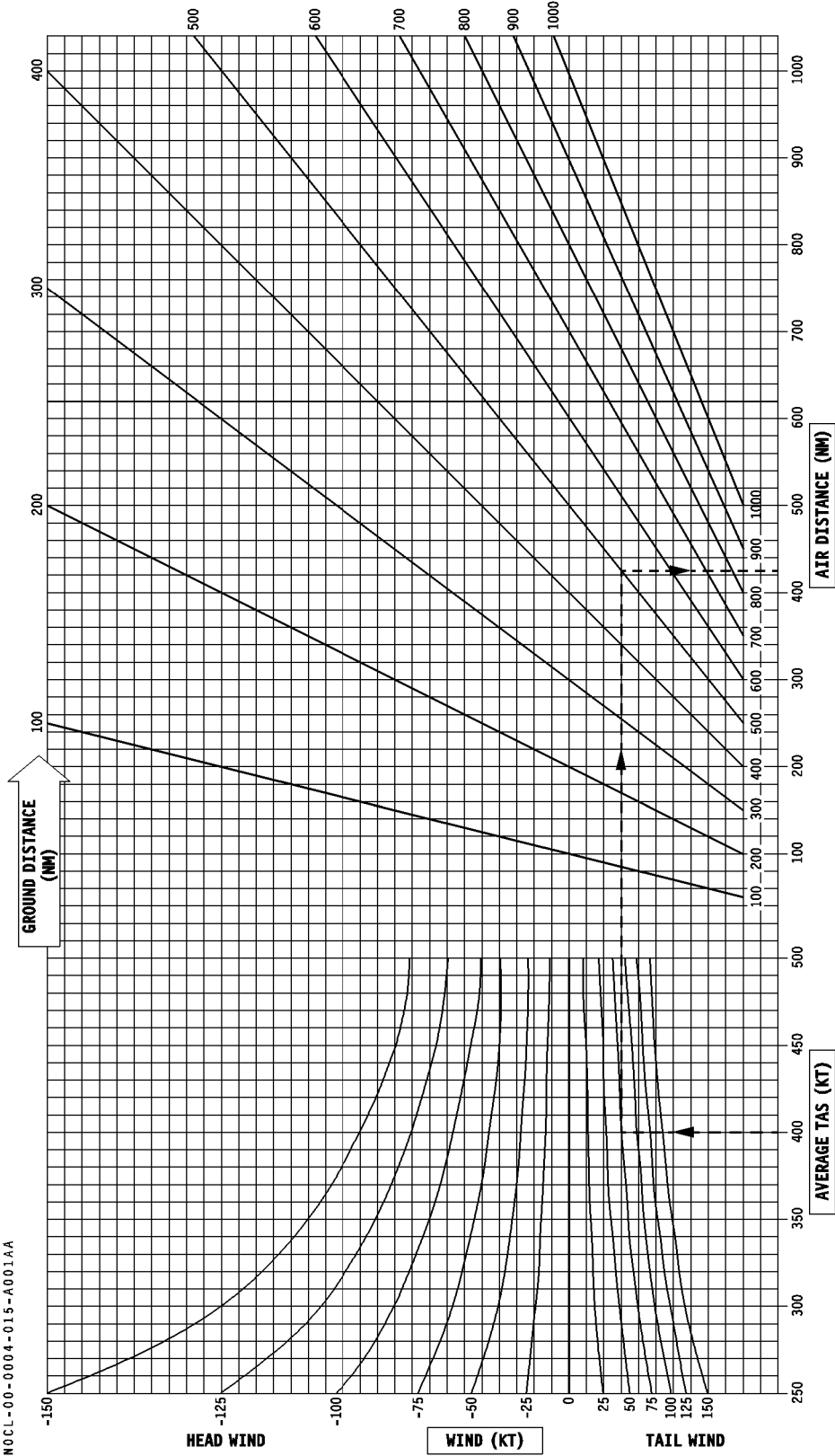

NOCL-00-0004-015-A001AA

IAS - MACH CONVERSION

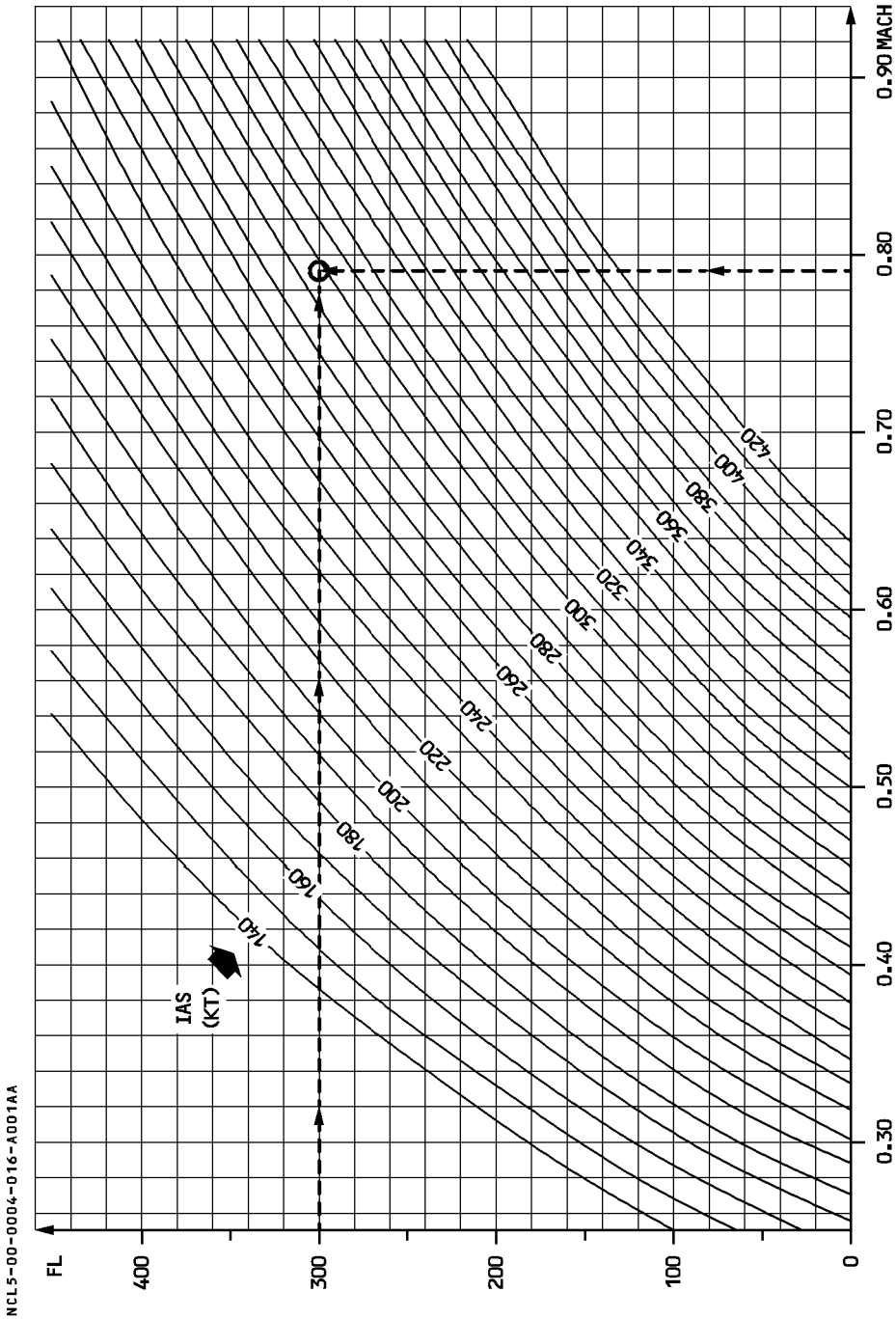

NCL5-00-0004-016-A001AA

CONTENTS

SEVERE TURBULENCE 5.01
HYD ARCHITECTURE 5.02
FLT CTL ARCHITECTURE 5.03
REQUIRED EQUIPMENT FOR CAT2 AND CAT3 5.04

R

SEVERE TURBULENCE

SPEED AND THRUST SETTING FOR RECOMMENDED TURBULENCE SPEED

FL	SPD or Mach	GROSS WEIGHT (1000 kg)										
		54	58	62	66	70	74	78	82	86	90	94
		N1 %										
390	0.76	79.4	80.6	—	—	—	—	—	—	—	—	—
370	0.76	77.9	78.9	80.0	81.2	—	—	—	—	—	—	—
350	0.76	77.2	77.9	78.8	79.7	80.7	—	—	—	—	—	—
330	0.76	76.9	77.6	78.2	79.0	79.8	80.7	81.6	—	—	—	—
310	0.76	76.7	77.3	77.9	78.5	79.2	79.9	80.6	81.5	82.4	—	—
290	0.76	76.7	77.2	77.7	78.2	78.8	79.4	80.0	80.6	81.4	82.1	83.0
270	300	76.2	76.6	77.0	77.5	78.0	78.5	79.1	79.6	80.3	80.9	81.6
250	300	75.0	75.4	75.8	76.2	76.7	77.1	77.7	78.2	78.9	79.5	80.2
200	300	72.2	72.5	72.9	73.3	73.7	74.2	74.7	75.2	75.8	76.4	77.0
150	270	65.5	65.9	66.5	67.0	67.7	68.4	69.2	70.3	71.0	71.8	72.6
100	270	62.5	62.9	63.5	64.0	64.6	65.3	66.0	66.8	67.6	68.4	69.2
50	270	59.1	59.5	60.0	60.5	61.1	61.8	62.6	63.4	64.2	65.0	65.7

- R
- SIGNS ON
 - AUTO PILOT KEEP ON
 - A/THR (when thrust changes become excessive) . DISCONNECT
 - **FOR APPROACH :**
 - A/THR in managed speed USE

HYD ARCHITECTURE

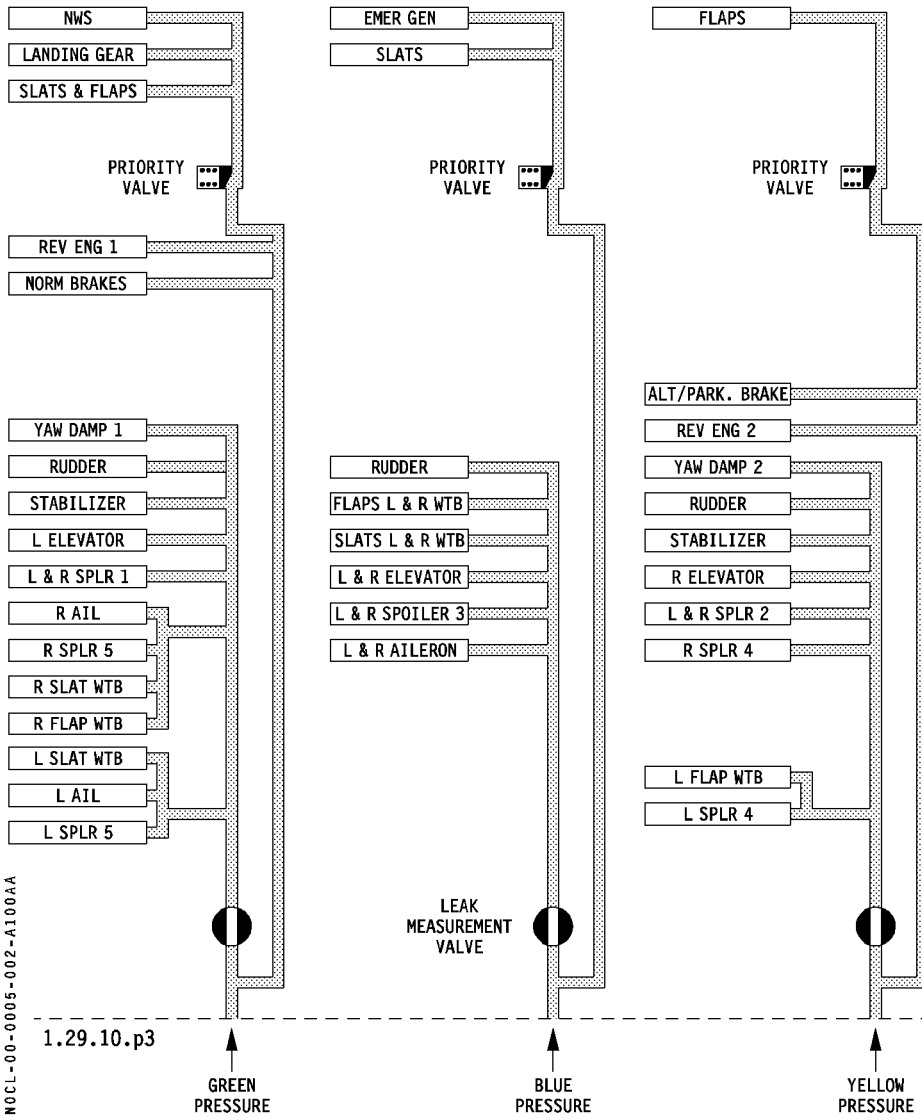

NOCL-00-0005-002-A100AA

Mod : 22013 or 24105 or 26334 or 26335

SEVERE TURBULENCE**SPEED AND THRUST SETTING FOR RECOMMENDED TURBULENCE SPEED**

FL	SPD or Mach	GROSS WEIGHT (1000 kg)								
		44	48	52	56	60	64	68	72	76
		N 1 %								
390	0.76	75.7	76.6	77.7	79.0	–	–	–	–	–
370	0.76	74.7	75.5	76.3	77.2	78.4	79.7	–	–	–
350	0.76	74.3	74.8	75.6	76.3	77.1	78.1	79.3	80.5	–
330	0.76	74.5	74.8	75.3	76.0	76.6	77.4	78.2	79.2	80.2
310	275	74.1	74.3	74.7	75.2	75.8	76.4	77.1	77.9	78.8
290	275	72.9	73.2	73.5	73.9	74.5	75.1	75.8	76.5	77.3
270	275	71.7	71.9	72.3	72.7	73.3	73.9	74.5	75.2	76.0
250	275	70.4	70.7	71.0	71.4	71.9	72.6	73.2	73.9	74.7
200	275	66.8	67.1	67.4	67.9	68.4	69.0	69.8	70.4	71.1
150	250	59.9	60.4	61.0	61.7	62.5	63.5	64.5	65.5	66.5
100	250	56.3	56.7	57.2	57.8	58.5	59.3	60.3	61.4	62.5
50	250	52.7	53.4	53.8	54.4	54.9	55.7	56.5	57.4	58.4

- R
- SIGNS ON
 - AUTO PILOT KEEP ON
 - A/THR (when thrust changes become excessive) . DISCONNECT
 - **FOR APPROACH :**
 - A/THR in managed speed USE

HYD ARCHITECTURE

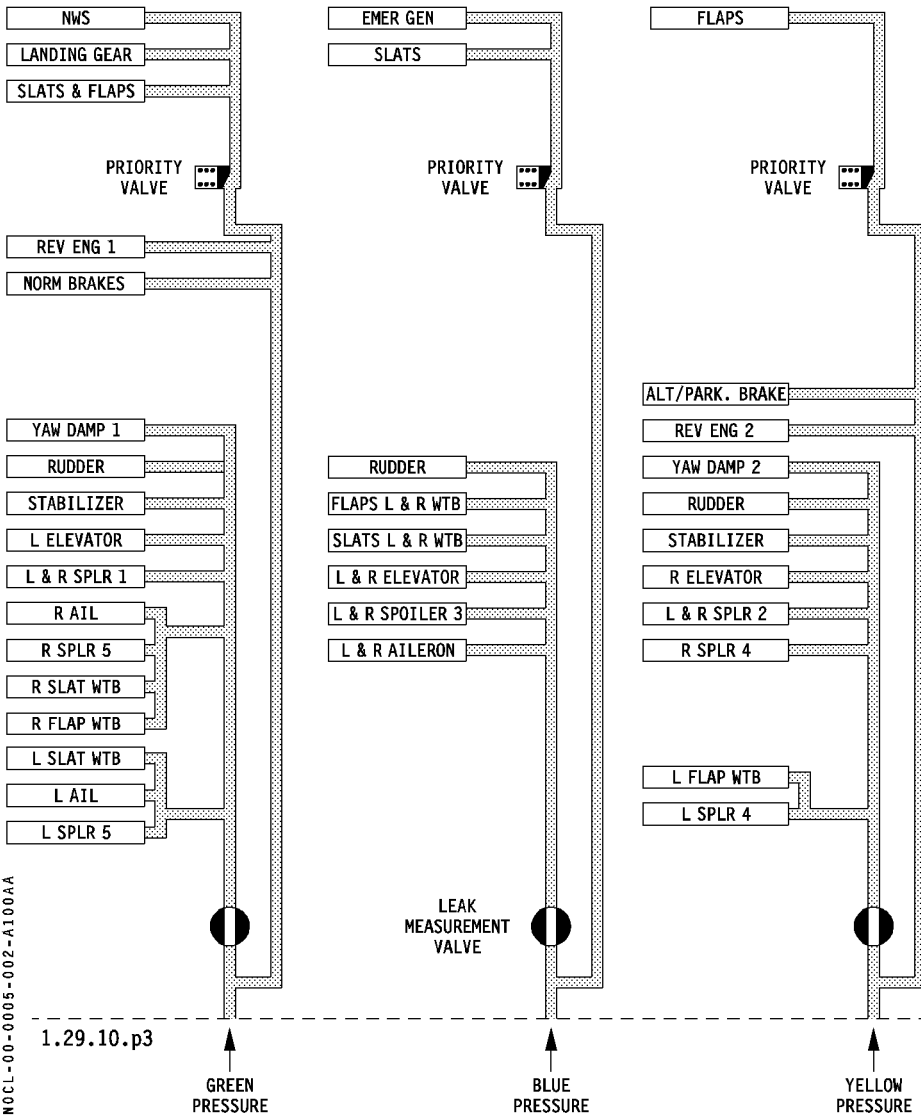

NOCL-00-0005-002-A100AA

Mod : 22013 or 24105 or 26334 or 26335

SEVERE TURBULENCE**SPEED AND THRUST SETTING FOR RECOMMENDED TURBULENCE SPEED**

FL	SPD or Mach	GROSS WEIGHT (1000 kg)								
		44	48	52	56	60	64	68	72	76
		N 1 %								
390	0.76	75.7	76.6	77.7	79.0	–	–	–	–	–
370	0.76	74.7	75.5	76.3	77.2	78.4	79.7	–	–	–
350	0.76	74.3	74.8	75.6	76.3	77.1	78.1	79.3	80.5	–
330	0.76	74.5	74.8	75.3	76.0	76.6	77.4	78.2	79.2	80.2
310	275	74.1	74.3	74.7	75.2	75.8	76.4	77.1	77.9	78.8
290	275	72.9	73.2	73.5	73.9	74.5	75.1	75.8	76.5	77.3
270	275	71.7	71.9	72.3	72.7	73.3	73.9	74.5	75.2	76.0
250	275	70.4	70.7	71.0	71.4	71.9	72.6	73.2	73.9	74.7
200	275	66.8	67.1	67.4	67.9	68.4	69.0	69.8	70.4	71.1
150	250	59.9	60.4	61.0	61.7	62.5	63.5	64.5	65.5	66.5
100	250	56.3	56.7	57.2	57.8	58.5	59.3	60.3	61.4	62.5
50	250	52.7	53.4	53.8	54.4	54.9	55.7	56.5	57.4	58.4

- R
- SIGNS ON
 - AUTO PILOT KEEP ON
 - A/THR (when thrust changes become excessive) . DISCONNECT
 - **FOR APPROACH :**
 - A/THR in managed speed USE

HYD ARCHITECTURE

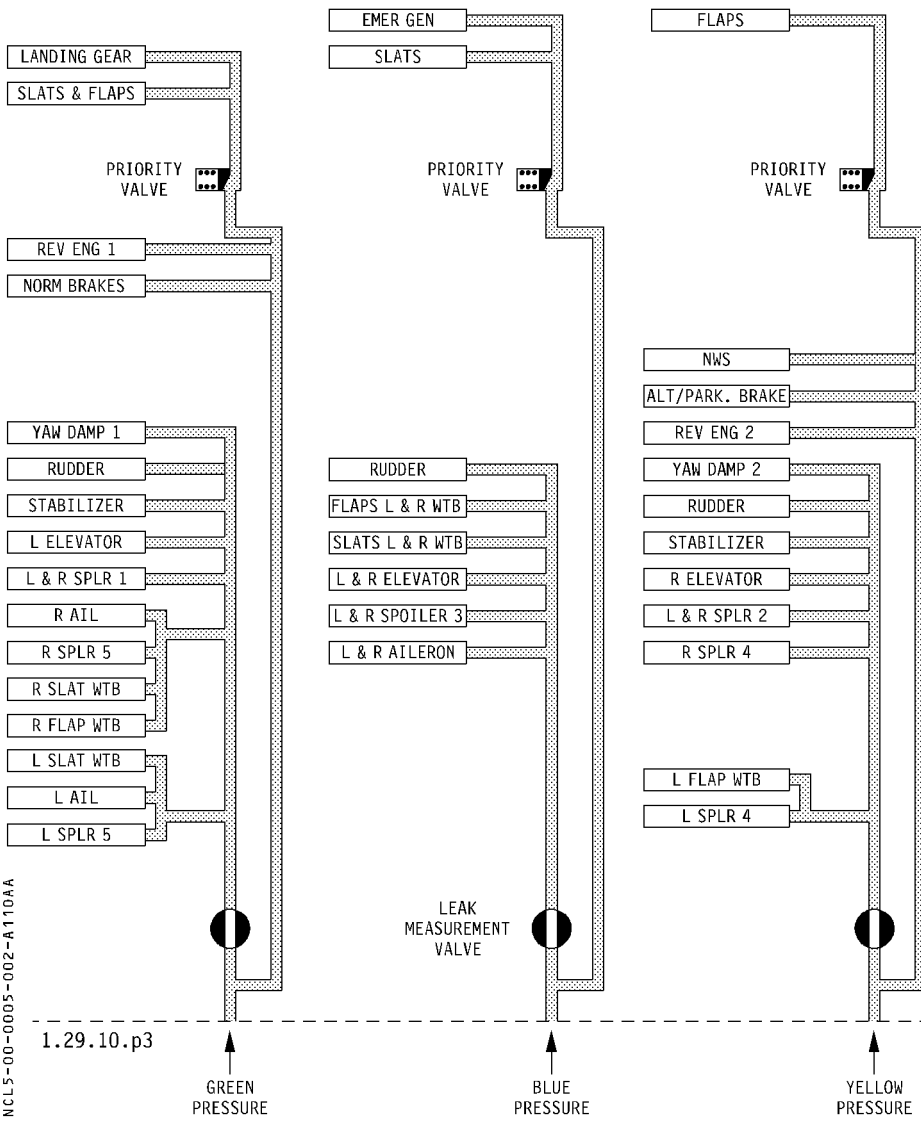

NCL5-00-0005-002-A110AA

1.29.10.p3

GREEN PRESSURE

BLUE PRESSURE

YELLOW PRESSURE

Mod : 26925

SEVERE TURBULENCE**SPEED AND THRUST SETTING FOR RECOMMENDED TURBULENCE SPEED**

FL	SPD or Mach	GROSS WEIGHT (1000 kg)									
		40	44	48	52	56	60	64	68	72	76
		N1 %									
410	0.76	75.7	76.8	78.0	79.6	–	–	–	–	–	–
390	0.76	74.7	75.6	76.5	77.6	79.0	–	–	–	–	–
370	0.76	74.0	74.6	75.4	76.2	77.1	78.3	79.6	–	–	–
350	0.76	73.9	74.2	74.8	75.5	76.2	77.1	78.0	79.2	80.4	–
330	0.76	74.2	74.4	74.7	75.2	75.9	76.6	77.3	78.1	79.1	80.2
310	275	73.8	74.0	74.3	74.6	75.1	75.7	76.3	77.0	77.8	78.7
290	275	72.6	72.8	73.1	73.4	73.9	74.4	75.0	75.7	76.4	77.2
270	275	71.3	71.5	71.8	72.2	72.6	73.2	73.8	74.5	75.1	75.9
250	275	70.1	70.3	70.6	70.9	71.3	71.9	72.5	73.1	73.8	74.6
200	275	66.4	66.6	66.9	67.3	67.7	68.2	68.9	69.7	70.3	70.9
150	250	60.3	60.6	60.9	61.4	62.0	62.7	63.4	64.3	65.2	66.2
100	250	56.9	57.2	57.6	58.0	58.6	59.2	59.9	60.7	61.6	62.6
50	250	54.0	54.3	54.7	55.2	55.8	56.4	57.1	57.9	58.7	59.6

- R
- SIGNS ON
 - AUTO PILOT KEEP ON
 - A/THR (when thrust changes become excessive) . DISCONNECT
 - **FOR APPROACH :**
 - A/THR in managed speed USE

HYD ARCHITECTURE

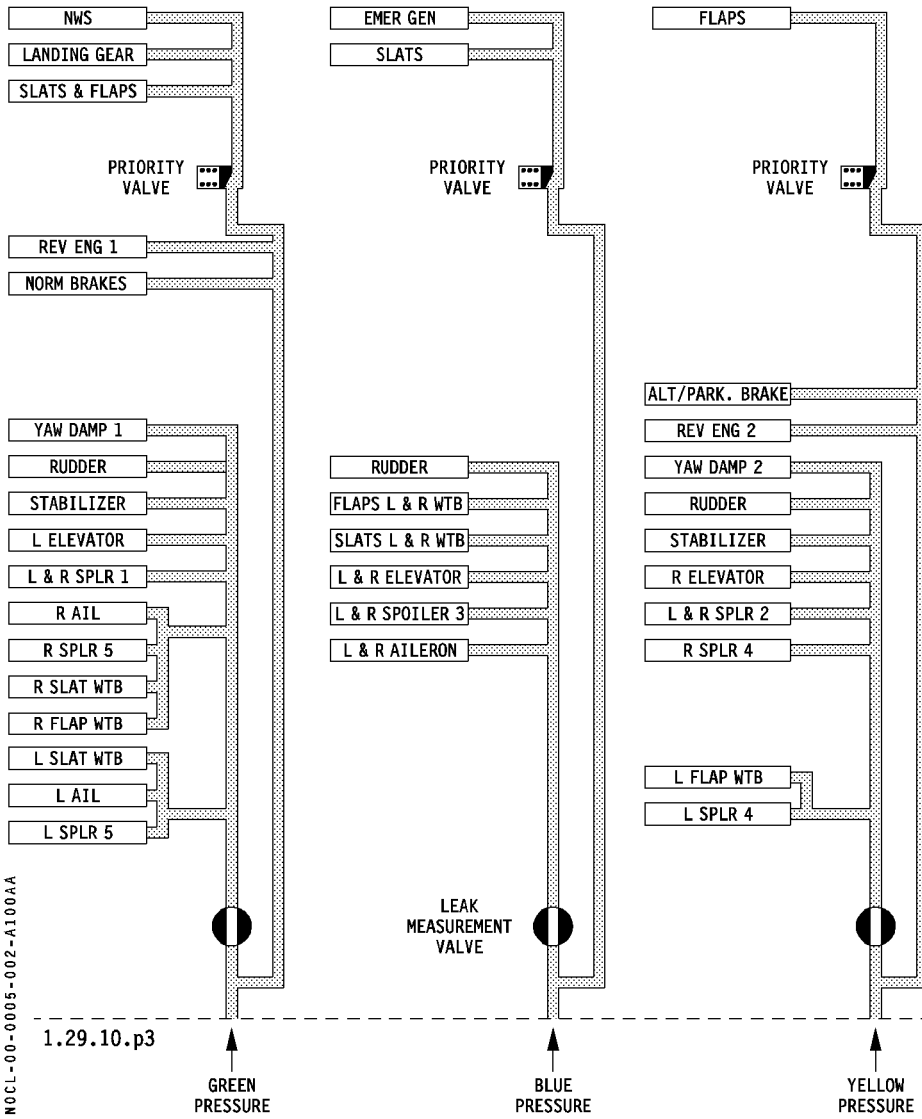

NOCL-00-0005-002-A100AA

1.29.10.p3

GREEN PRESSURE

BLUE PRESSURE

YELLOW PRESSURE

Mod : 22013 or 24105 or 26334 or 26335

FLT CTL ARCHITECTURE

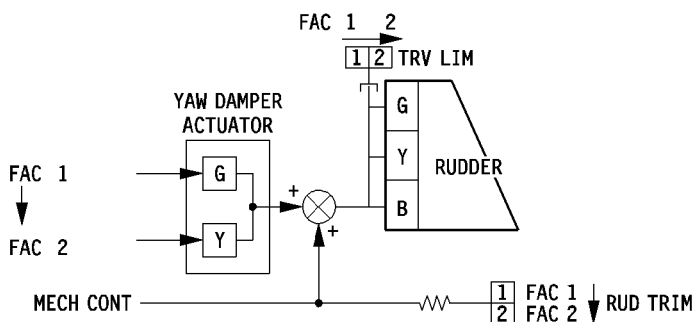
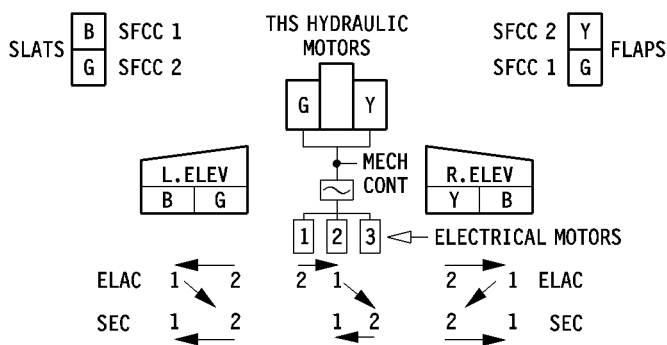
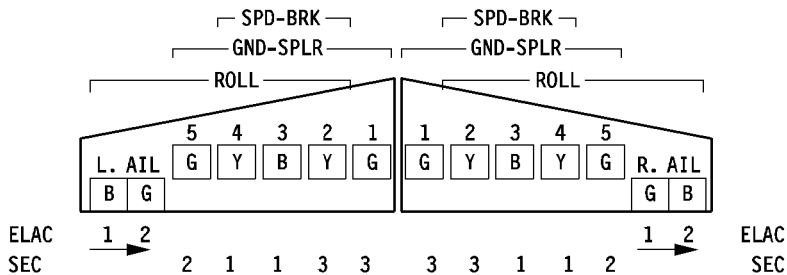

MOCL-00-0005-003-A100AA

Mod : 22013 or 24105 or 26334 or 26335

→ Arrows indicate the control reconfiguration priorities

G **B** **Y** indicates the hydraulic power source for each servo control

REQUIRED EQUIPMENT FOR CAT II AND CAT III

	FMA CAPABILITY →	CAT 2	CAT 3 SINGLE	CAT 3 DUAL
	EQUIPMENT ↓			
FMGS MONITORED FOR FMA LDG CAPABILITY	AP/FD	1 AP ENGAGED	1 AP ENGAGED	2 AP ENGAGED
	AUTOTHRUST	0	1	1
	FMA	1	2	2
	A/THR CAUTION	0	1	1
	ELECTRICAL SUPPLY SPLIT	0	0	1
	FAC	1	1	2
	ELAC	1	1	2
	YAW DAMPER/RUDDER TRIM	1/1	1/1	2/2
	HYDRAULIC CIRCUIT	2	2	3
	PFD DUs	2	2	2
	FLIGHT WARNING COMPUTER	1	1	2
	BSCU CHANNEL	1*	1*	1
	ANTISKID	1*	1*	1
	NOSEWHEEL STEERING	1*	1*	1
	RADIO ALTIMETER	1 (displayed on both sides)	2	2
	ILS RECEIVER	2	2	2
	BEAM EXCESSIVE DEVIATION WARNING	1 for PNF	2	2
	ATTITUDE INDICATION (PFD1/PFD2)	N° 1 + N° 2	N° 1 + N° 2	N° 1 + N° 2
	ADR/IR	2/2	2/2	3/3
	NOT FMGS MONITORED FOR FMA LDG CAPABILITY	AP DISCONNECT PB	2	2
"AP OFF" ECAM WARNING		1	1	2
"AUTOLAND" LIGHT		1	1	1
RUDDER TRAVEL LIMIT SYSTEM		1 required for autoland with crosswind higher than 12 kt		
WINDSHIELD HEAT (L or R windshield)		1 for PF		
WINDSHIELD WIPERS OR RAIN REPELLENT (if activated)		1 for PF		
ND DUs		1	2	2
AUTO CALLOUT FUNCTION		one is required for autoland	1	1
ATTITUDE INDICATION (STBY)		1	1	1
DH INDICATION	1 for PNF			

R

* For automatic rollout, one is required. For autoland without automatic rollout, none is required.

Note : . Flight crews are not expected to check the equipment list before approach. When an ECAM or local caution occurs, the crew should use the list to confirm the landing capability.
 . On ground, the equipment list determines which approach category the aircraft will be able to perform at the next landing.
 . Electrical power supply split : This ensures that each FMGC is powered by an independent electrical source (AC and DC).
 . Failure of antiskid and/or nosewheel steering mechanical parts are not monitored for landing capability.
 . The DH will be displayed on the FMA, and the "Hundred Above" and "Minimum" auto callouts will be announced, provided that the DH value has been entered on the MCDU.

ENGINE TAILPIPE FIRE

Internal engine fire may be encountered during engine start or engine shutdown. It may be seen by the ground crew, or the EGT may fail to decrease after the MASTER switch is turned off.

CAUTION

External fire agents can cause severe corrosive damage and should, therefore, only be considered after having applied the following procedure:

- MAN START (if manual start performed) OFF
- ENG MASTER (affected) OFF
- Note: Do not press the engine fire pushbutton, since this would cut off the FADEC power supply, which would prevent motoring sequence.*
- AIR BLEED PRESS ESTABLISH
 - Select the APU, or opposite BLEED, to motor the engine.
 - If APU BLEED is not available, and the opposite engine is shut down, connect external pneumatic power (if readily available).
- BEACON ON
- ENG MODE SEL CRANK
- MAN START ON
The start valve automatically reopens, when N2 is below 10 %.
- **When burning has stopped:**
 - MAN START OFF
 - ENG START SEL NORM
 - Maintenance action is due.

(AIRBUS QRH 2.23 : REV 37 / SEQ 035)

RVSM CONTINGENCY

ATC INFORM

ATC must be informed of any of the following equipment failures:

- All Altitude Control Systems
- Loss of redundancy of altimeter systems
- Loss of thrust on an engine requiring descent
- Any piece of equipment that affects the ability of the aircraft to maintain the FL.

ATC will take immediate action to provide a minimum of 2000 ft vertical separation from all other aircraft.

During severe turbulence encounters ATC must be informed.

ON GROUND EMER EVACUATION

- AIRCRAFT / PARKING BRK STOP/ ON
- ATC (VHF 1) NOTIFY
- CABIN CREW (PA) ALERT
- Δ P (only if MAN CAB PR has been used) CHECK ZERO
If not zero, MODE SEL on MAN, V/S CTL FULL UP.
- ENG MASTERS 1 and 2 OFF
- FIRE P/Bs (ENG and APU) PUSH
- AGENTS (ENG and APU) AS RQRD
- **IF EVACUATION REQUIRED :**
 - EVACUATION INITIATE
- **IF EVACUATION NOT REQUIRED :**
 - CABIN CREW and PASSENGERS (PA) NOTIFY

(AIRBUS QRH 7.00 : REV 40 / SEQ 001)

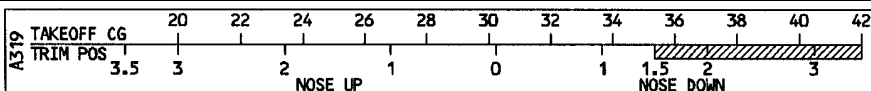

ENGINE TAILPIPE FIRE

Internal engine fire may be encountered during engine start or engine shutdown. It may be seen by the ground crew, or the EGT may fail to decrease after the MASTER switch is turned off.

CAUTION

External fire agents can cause severe corrosive damage and should, therefore, only be considered after having applied the following procedure:

- MAN START (if manual start performed)OFF
- ENG MASTER (affected)OFF
- Note: Do not press the engine fire pushbutton, since this would cut off the FADEC power supply, which would prevent motoring sequence.*
- AIR BLEED PRESS ESTABLISH
 - Select the APU, or opposite BLEED, to motor the engine.
 - If APU BLEED is not available, and the opposite engine is shut down, connect external pneumatic power (if readily available).
- BEACONON
- ENG MODE SEL CRANK
- MAN STARTON
The start valve automatically reopens, when N2 is below 10 %.

● **When burning has stopped:**

- MAN STARTOFF
- ENG START SEL NORM
- Maintenance action is due.

(AIRBUS QRH 2.23 : REV 37 / SEQ 035)

RVSM CONTINGENCY

ATC INFORM

ATC must be informed of any of the following equipment failures:

- All Altitude Control Systems
- Loss of redundancy of altimeter systems
- Loss of thrust on an engine requiring descent
- Any piece of equipment that affects the ability of the aircraft to maintain the FL.

ATC will take immediate action to provide a minimum of 2000 ft vertical separation from all other aircraft.

During severe turbulence encounters ATC must be informed.

ON GROUND EMER EVACUATION

- AIRCRAFT / PARKING BRK STOP/ ON
- ATC (VHF 1) NOTIFY
- CABIN CREW (PA) ALERT
- Δ P (only if MAN CAB PR has been used) CHECK ZERO
If not zero, MODE SEL on MAN, V/S CTL FULL UP.
- ENG MASTERS 1 and 2 OFF
- FIRE P/Bs (ENG and APU) PUSH
- AGENTS (ENG and APU) AS RQRD

● **IF EVACUATION REQUIRED :**

- EVACUATION INITIATE

● **IF EVACUATION NOT REQUIRED :**

- CABIN CREW and PASSENGERS (PA) NOTIFY

(AIRBUS QRH 7.00 : REV 40 / SEQ 001)

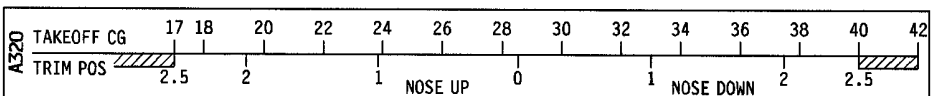

ENGINE TAILPIPE FIRE

Internal engine fire may be encountered during engine start or engine shutdown. It may be seen by the ground crew, or the EGT may fail to decrease after the MASTER switch is turned off.

CAUTION

External fire agents can cause severe corrosive damage and should, therefore, only be considered after having applied the following procedure:

- MAN START (if manual start performed)OFF
- ENG MASTER (affected)OFF
- Note: Do not press the engine fire pushbutton, since this would cut off the FADEC power supply, which would prevent motoring sequence.*
- AIR BLEED PRESS ESTABLISH
 - Select the APU, or opposite BLEED, to motor the engine.
 - If APU BLEED is not available, and the opposite engine is shut down, connect external pneumatic power (if readily available)
- BEACONON
- ENG MODE SEL CRANK
- MAN STARTON
- The start valve automatically reopens, when N2 is below 10 %.*
- **When burning has stopped:**
 - MAN STARTOFF
 - ENG START SEL NORM
 - Maintenance action is due.

(AIRBUS QRH 2.23 : REV 37 / SEQ 035)

RVSM CONTINGENCY

ATC INFORM

ATC must be informed of any of the following equipment failures:

- All Altitude Control Systems
- Loss of redundancy of altimeter systems
- Loss of thrust on an engine requiring descent
- Any piece of equipment that affects the ability of the aircraft to maintain the FL.

ATC will take immediate action to provide a minimum of 2000 ft vertical separation from all other aircraft.

During severe turbulence encounters ATC must be informed.

ON GROUND EMER EVACUATION

- AIRCRAFT / PARKING BRK STOP/ ON
- ATC (VHF 1) NOTIFY
- CABIN CREW (PA) ALERT
- Δ P (only if MAN CAB PR has been used) CHECK ZERO
- If not zero, MODE SEL on MAN, V/S CTL FULL UP.*
- ENG MASTERS 1 and 2 OFF
- FIRE P/Bs (ENG and APU) PUSH
- AGENTS (ENG and APU) AS RQRD
- **IF EVACUATION REQUIRED :**
 - EVACUATION INITIATE
- **IF EVACUATION NOT REQUIRED :**
 - CABIN CREW and PASSENGERS (PA) NOTIFY

(AIRBUS QRH 7.00 : REV 40 / SEQ 001)

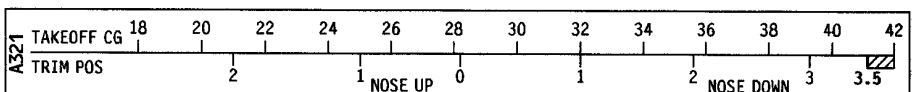

A319/A320/A321 NORMAL CHECK LIST

REV. 06

PAGE 1 OF 2

BEFORE START

GEAR PINS and COVERS _____ REMOVED
MOBILE PHONES _____ OFF (B)
COCKPIT PREP _____ COMPLETED (B)
ADIRS _____ NAV
BARO REF _____ SET / X-CHECKED (B)
BRIEFING _____ CONFIRMED

----- LOADSHEET -----

PARK BRAKE _____ ON
SIGNS _____ ON / AUTO
FUEL ____ PUMPS ON / ____ KGS CHECKED
T.O SPDS / FLEX TEMP _____ SET (B)

PUSH/ START

WINDOWS AND DOORS _____ CLOSED (B)
BEACON _____ ON
THR LEVERS _____ IDLE
A/SKID & NW STRG _____ AS RQRD
NW STRG DISC MSG _____ AS RQRD

AFTER START

ASKID & NW STRG _____ ON
ANTI ICE _____ AS RQRD
ECAM STATUS _____ CHECKED
TRIMS _____ % / ZERO
GROUND CREW CLEARANCE ____ RECEIVED

BEFORE TAKE OFF

FLIGHT CONTROLS _____ CHECKED (B)
FLAP SETTING _____ CONF ____ (B)
T.O. SPD / FLX TEMP _____ SET (B)
ATC _____ SET
ECAM MEMO _____ T/O NO BLUE

- AUTO BRK MAX
- SIGNS ON
- SPLRS ARMED
- FLAPS T.O.
- T.O. CONFIG NORM

----- ENTERING RUNWAY -----

CABIN _____ SECURED / SIGNALLED
PACKS _____ AS RQRD

AFTER TAKE OFF

LDG GEAR _____ UP
ECAM MEMO _____ CHECKED

----- CLEARED TO FL -----

BARO REF _____ STD / X-CHECKED (B)

DESCENT

SEAT BELTS _____ ON
ECAM STATUS _____ CHECKED
BRIEFING _____ CONFIRMED

----- CLEARED TO ALTITUDE -----

BARO REF _____ QNH / X-CHECKED (B)

LANDING

CABIN _____ SECURED / SIGNALLED
A/THR _____ SPEED / OFF
ECAM MEMO _____ LDG NO BLUE

- L/G DOWN
- SIGNS ON
- SPLRS ARMED
- FLAPS SET

AFTER LANDING

WX RADAR OFF
PRED W/S OFF
SPOILERS DISARMED
FLAPS RETRACTED
TCAS STBY
APU START

SHUTDOWN

PARK BRAKE _____ AS RQRD
ENGINES _____ OFF
SEAT BELTS _____ OFF
FUEL PUMPS _____ OFF
BEACON _____ OFF

SECURING THE AIRCRAFT

OXYGEN OFF
ADIRS OFF
NO SMOKING OFF
EMER EXIT LTS OFF
APU BLEED OFF
EXT PWR AS RQRD
APU MASTER SW OFF
BATTERIES OFF

BEFORE LEAVING THE AIRCRAFT

LPC _____ AS RQRD (B)
TRIP KIT _____ AS RQRD (B)

NOTES:

- 1) _____ PNF reads PF replies _____
- 2) PNF reads PNF replies
- 3) (B) PNF Reads and both PF then PNF replies

A319/A320/A321 NORMAL CHECK LIST

REV. 06

PAGE 2 OF 2

PRELIMINARY COCKPIT PREPARATION

GEAR PINS and COVERS	REMOVED
ENGINE PANEL	CHECK
LANDING GEAR LEVER	DOWN
BATTERIES	25.5V/ AUTO
DU'S	ON
PARK BRAKE	CHECKED / AS RQRD
FLAP LEVER	CHECKED
SPEED BRAKE LEVER	DISARMED
ECAM	CHECKED

TURBULENCE SPEEDS

Below ----- Above 20000 feet	A319/A320	A321
	250 --- 275 / M0.76	270 --- 300 / M0.76

TAKE-OFF BRIEF

AIRCRAFT TYPE / EMERGENCIES / MEL / NOTAMS / SIG. WEATHER/ RETURN ALTERNATE / RUNWAY / FLAP / ACCEL ALT / TRANSITION ALT / TERRAIN / PERFORMANCE RESTRICTIONS / MINIMUM SAFE ALTITUDE / SID / RADIO AIDS / FMGC / FD/ REVIEW.

APPROACH BRIEF

AIRCRAFT TYPE / CONFIGURATION / NOTAMS/ WEATHER / QNH / TRANSITION LEVEL/ MINIMUM SAFE ALTITUDE/ STAR/ APPROACH/ AIRFIELD ELEVATION/ GO AROUND/ RUNWAY/ STOPPING/ RADIO AIDS / ALTERNATE/ FUEL CAPABILITY/ REVIEW.

ALL WEATHER OPERATIONS BRIEFING GUIDE

In addition to the normal approach briefing the following items should be covered:

- CREW QUALIFICATION** – Both members qualified for approach type
- GROUND & AIRCRAFT EQUIPMENT STATUS** – All equipment for approach is serviceable.
- ALTERNATE** – Weather above minima required and fuel sufficient for diversion.
- DOWNGRADE OPTIONS** – Options with regard to current RVR. Any downgrade option to be taken above 1000 feet.
- FLIGHT DECK LIGHTING** – Internal lights to be set to minimum brightness consistent with viewing instruments.
- SEAT POSITION** – Captain's seat affords good view over a/c nose and F/O a clear view of instruments.

WEIGHTS/KG	MTOW	MLW	MZFW	MAX FUEL*
A319	75 500	62 500	58 500	20 900
A320	77 000	66 000	62 500	18 600
A321	93 000	77 800	73 800	20 800
A7-ABR	77 000	64 500	61 000	18 600

* Based on SG = 0,780

Published Missed Approach Vs Takeoff EOSID

The flow chart details the process of determining whether an aircraft has the performance to meet the published missed approach procedure in the engine out scenario. If it does not, then the takeoff EOSID shall be flown as the EOMA.

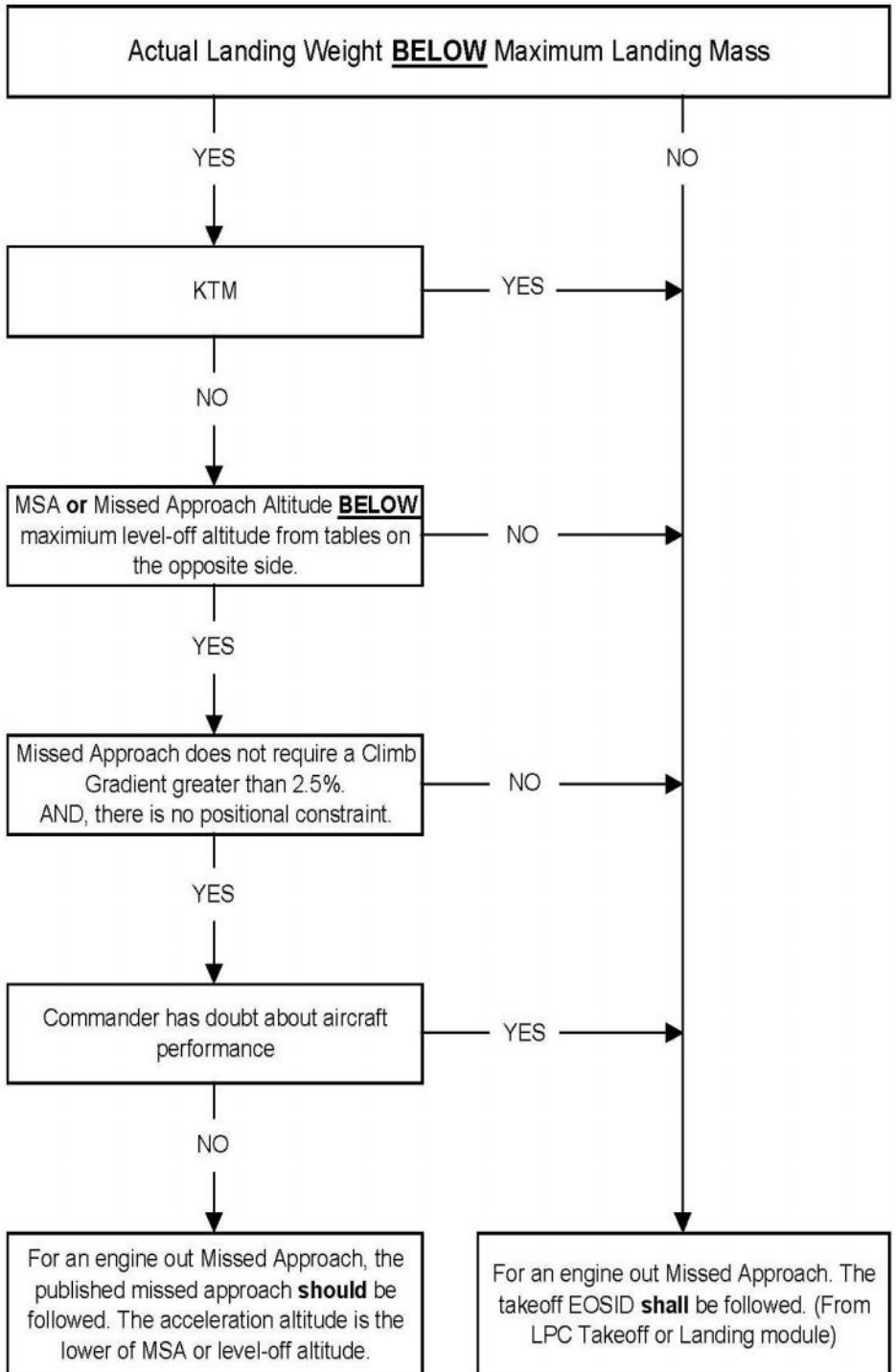

ENGINE OUT MISSED APPROACH (EOMA) A319-133

REV. 00

PAGE 2 OF 2

Maximum Structural Landing Mass (62,500kg) Approach Climb CONF 3			
Pressure Altitude	ISA+30 and below	ISA+35	ISA+40
0 ft	4800 ft	4800 ft	4600 ft
1000 ft	5600 ft	5600 ft	4300 ft
2000 ft	6500 ft	6500 ft	4000 ft
3000 ft	7400 ft	7200 ft	6700 ft
4000 ft	8100 ft	7900 ft	7400 ft
5000 ft	8900 ft	8600 ft	
6000 ft	9600 ft	9300 ft	
7000 ft	10300 ft		

Table 1: Maximum Level-off Altitude Table

Maximum Structural Landing Mass (62,500kg) Approach Climb CONF 2			
Pressure Altitude	ISA+30 And below	ISA+35	ISA+40
0 ft	6000 ft	6000 ft	5800 ft
1000 ft	6800 ft	6800 ft	6400 ft
2000 ft	7700 ft	7700 ft	5100 ft
3000 ft	8500 ft	8400 ft	7800 ft
4000 ft	9200 ft	9100 ft	8500 ft
5000 ft	10000 ft	9800 ft	9200 ft
6000 ft	10700 ft	10400 ft	9800 ft
7000 ft	11400 ft	11100 ft	10400 ft
8000 ft	12000 ft	11700 ft	
9000 ft	12600 ft	12200 ft	

Table 2: Maximum Level-off Altitude Table

Based on:

Climbing on Runway heading followed by a 180° turn in heading
AC ON (AC OFF correction not calculated!)

V_{LS}+5 (Correction for increased approach speed not calculated)

Published Missed Approach Vs Takeoff EOSID

The flow chart details the process of determining whether an aircraft has the performance to meet the published missed approach procedure in the engine out scenario. If it does not, then the takeoff EOSID shall be flown as the EOMA.

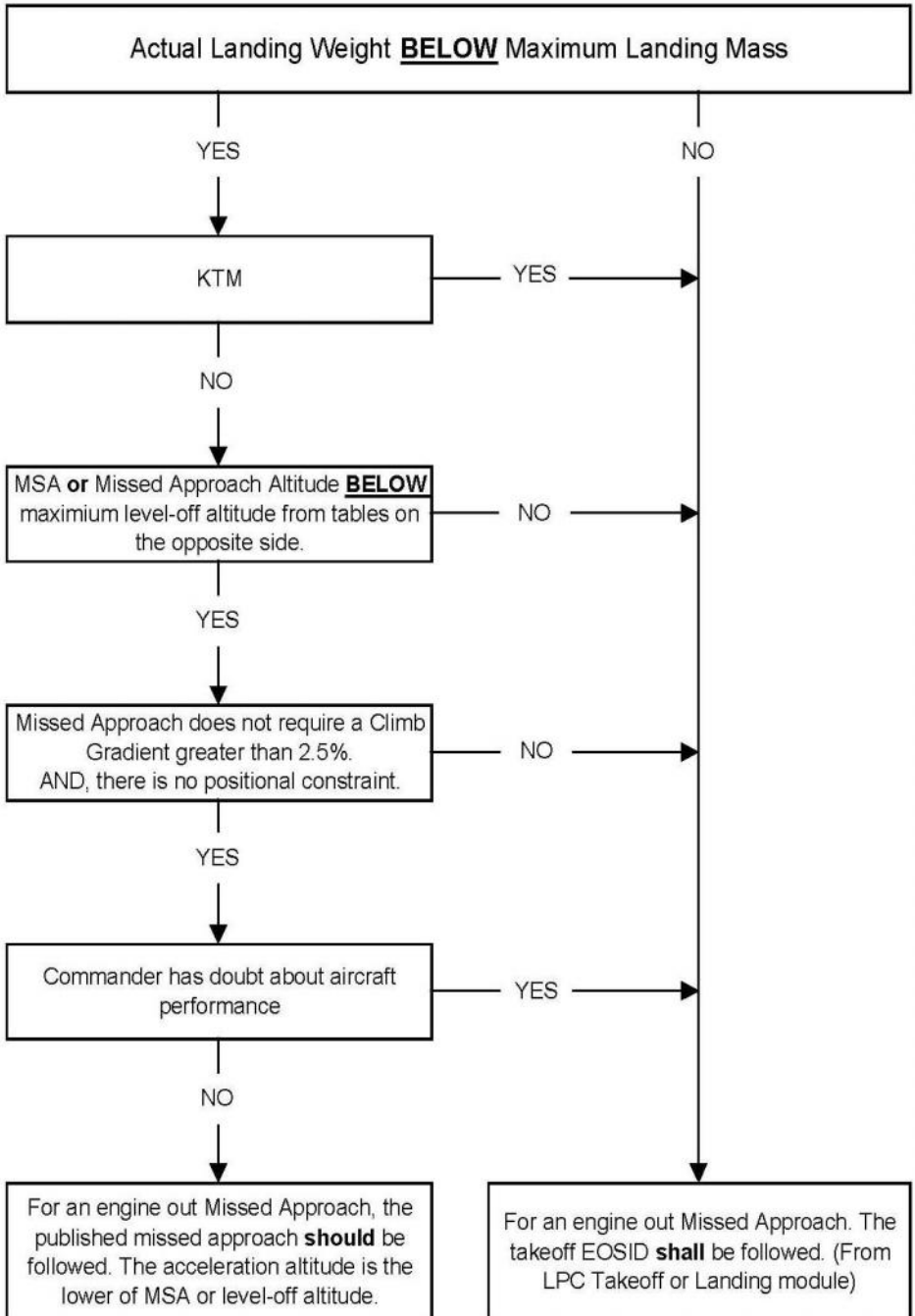

ENGINE OUT MISSED APPROACH (EOMA) A320-232

REV. 00

PAGE 2 OF 2

Maximum Structural Landing Mass (66,000kg) Approach Climb CONF 3				
Pressure Altitude	ISA+25 and below	ISA+30	ISA+35	ISA+40
0 ft	5700 ft	5700 ft	5100 ft	4500 ft
1000 ft	6300 ft	6300 ft	5700 ft	5100 ft
2000 ft	7100 ft	6900 ft	6300 ft	5700 ft
3000 ft	7800 ft	7600 ft	7000 ft	6400 ft
4000 ft	8400 ft	8200 ft	7600 ft	
5000 ft	9100 ft	8800 ft	8300 ft	
6000 ft	9700 ft	9500 ft		
7000 ft	10300 ft			

Table 1: Maximum Level-off Altitude Table

Maximum Structural Landing Mass (66,000kg) Approach Climb CONF 2				
Pressure Altitude	ISA+25 and below	ISA+30	ISA+35	ISA+40
0 ft	6000 ft	6000 ft	5400 ft	4700 ft
1000 ft	6700 ft	6600 ft	6000 ft	5400 ft
2000 ft	7400 ft	7200 ft	6600 ft	6000 ft
3000 ft	8100 ft	7900 ft	7300 ft	6600 ft
4000 ft	8700 ft	8500 ft	7900 ft	7300 ft
5000 ft	9400 ft	9100 ft	8600 ft	
6000 ft	10000 ft	9700 ft	9200 ft	
7000 ft	10600 ft	10400 ft		

Table 2: Maximum Level-off Altitude Table

Based on:

Climbing on Runway heading followed by a 180° turn in heading
AC ON (AC OFF correction not calculated!)

V_{LS}+5 (Correction for increased approach speed not calculated)

Published Missed Approach Vs Takeoff EOSID

The flow chart details the process of determining whether an aircraft has the performance to meet the published missed approach procedure in the engine out scenario. If it does not, then the takeoff EOSID shall be flown as the EOMA.

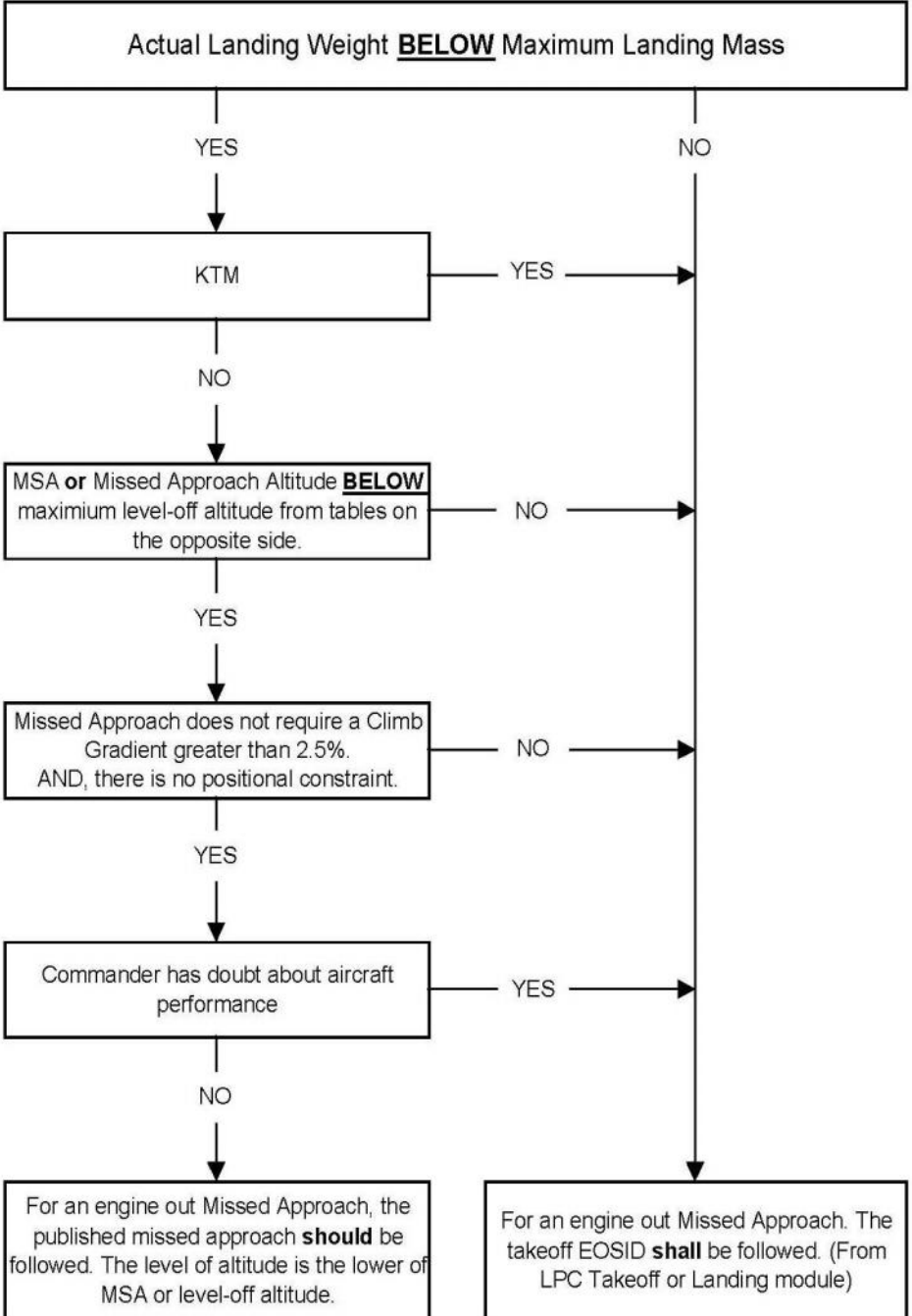

Maximum Structural Landing Mass (77,800kg and below) Approach Climb CONF 3						
Pressure Altitude	ISA	ISA+20	ISA+25	ISA+30	ISA+35	ISA40
0 ft	4500 ft	4300 ft	3800 ft	3200 ft		
1000 ft	5100 ft	5000 ft	4500 ft			
2000 ft	5700 ft	5600 ft	5100 ft			
2500 ft	5900 ft	5900 ft				

Table 1: Maximum Level-off Altitude Table

Landing Mass 74,000kg and below Approach Climb CONF 3						
Pressure Altitude	ISA	ISA+20	ISA+25	ISA+30	ISA+35	ISA+40
0 ft	5300 ft	5100 ft	4600 ft	4000 ft	3300 ft	
1000 ft	5800 ft	5800 ft	5300 ft	4700 ft		
2000 ft	6300 ft	6300 ft	5900 ft	5300 ft		
3000 ft	6900 ft	6900 ft	6500 ft			
4000 ft	7400 ft	7400 ft				

Table 2: Maximum Level-off Altitude Table

Maximum Structural Landing Mass (77,800kg and below) Approach Climb CONF 2						
Pressure Altitude	ISA	ISA+20	ISA+25	ISA+30	ISA+35	ISA+40
0 ft	5500 ft	5400 ft	4900 ft	4200 ft	3500 ft	
1000 ft	6100 ft	6000 ft	5500 ft	4900 ft		
2000 ft	6600 ft	6600 ft	6100 ft	5500 ft		
3000 ft	7100 ft	7100 ft	6700 ft			
4000 ft	7600 ft	7600 ft				

Table 3: Maximum Level-off Altitude Table

Landing Mass 74,000kg and below Approach Climb CONF 2						
Pressure Altitude	ISA	ISA+20	ISA+25	ISA+30	ISA+35	ISA+40
0 ft	5700 ft	5700 ft	5200 ft	4600 ft	3900 ft	
1000 ft	6400 ft	6300 ft	5800 ft	5200 ft	4600 ft	
2000 ft	6900 ft	6800 ft	6400 ft	5900 ft		
3000 ft	7400 ft	7400 ft	7100 ft	6600 ft		
4000 ft	7900 ft	7900 ft	7700 ft			
5000 ft	8400 ft	8400 ft	8300 ft			

Table 4: Maximum Level-off Altitude

Based on:

Climbing on Runway heading followed by a 180° turn in heading
AC ON (AC OFF correction not calculated!)

V_{LS}+5 (Correction for increased approach speed not calculated).

THIS TABLE GIVES, FOR EACH AIRCRAFT INCLUDED IN THE MANUAL, THE CROSS REFERENCE BETWEEN :

- THE MANUFACTURING SERIAL NUMBER (MSN) WHICH APPEARS IN THE LIST OF EFFECTIVE PAGES
- THE REGISTRATION NUMBER OF THE AIRCRAFT AS KNOWN BY AIRBUS INDUSTRIE.

MSN	REGISTRATION
0928	A7-ABR
1566	A7-ADA
1648	A7-ADB
1656	A7-CJA
1773	A7-ADC
1895	A7-ADD
1928	A7-ADS
1957	A7-ADE
2097	A7-ADF
2107	A7-ADT
2121	A7-ADG
2138	A7-ADH
2161	A7-ADI
2288	A7-ADJ
2341	A7-CJB
3071	

LIST OF EFFECTIVE PAGES (LEP)

M ---PAGE--- SEQ- --REV-- ----VALIDATION CRITERIA-----

M ---PAGE--- SEQ- --REV-- ----VALIDATION CRITERIA-----

-----EFFECTIVITY-----

```

-----
0 .00      001 REV040
           ALL

0 .00A     001 REV037
           ALL

0 .01      001 REV040 LIST OF CODES
0 .02      001 REV040 LIST OF CODES
           ALL

0 .02A     001 REV040 LIST OF CODES
           ALL

0 .02B     001 REV040 LIST OF CODES
           ALL

0 .02C     001 REV040 LIST OF CODES
           ALL

0 .02D     001 REV040 LIST OF CODES
           ALL

0 .02E     001 REV040 LIST OF CODES
           ALL

0 .02F     001 REV040 LIST OF CODES
           ALL

0 .02G     001 REV040 LIST OF CODES
           ALL

0 .02H     001 REV040 LIST OF CODES
           ALL

0 .02I     001 REV040 LIST OF CODES
           ALL

0 .02J     001 REV040 LIST OF CODES
           ALL

0 .02K     001 REV040 LIST OF CODES
           ALL

0 .02L     001 REV040 LIST OF CODES
           ALL

0 .02M     001 REV040 LIST OF CODES
           ALL

0 .02N     001 REV040 LIST OF CODES
           ALL

0 .02O     001 REV040 LIST OF CODES
           ALL

0 .03-     001 REV040 LIST OF TEMPORARY REVISIONS
           ALL

0 .04-     001 REV040 CROSS REFERENCE TABLE
           ALL

0 .06-     001 REV040 LIST OF EFFECTIVE PAGES
           ALL

0 .07-     001 REV040 LIST OF MOD/MP/SB
           ALL

1 .00      001 REV040
           ALL

1 .01      205 REV032 M:21678+21858
1 .02      100 REV032 M:21678
           1656 2341

1 .01      410 REV032 M:21678+21706+21768+21858
1 .02      100 REV032 M:21678
           0928-1648 1773-2288 3071

1 .03      200 REV036 CODE 0197
1 .04      350 REV032 M:21285+21678+25404/IAE
           0928

1 .03      305 REV037 M:21678+26999+27620
1 .04      350 REV032 M:21285+21678+25404/IAE
           1566-2341

N 1 .03     405 REV040 CODE 0080
N 1 .04     350 REV032 M:21285+21678+25404/IAE
           3071

1 .05      466 REV040 CODE:0147/V2533
1 .06      100 REV040 22013
           1928 2107

```

LIST OF EFFECTIVE PAGES (LEP)

M ---PAGE--- SEQ- --REV-- ----VALIDATION CRITERIA-----
M ---PAGE--- SEQ- --REV-- ----VALIDATION CRITERIA-----
-----EFFECTIVITY-----

1 .05 550 REV040 CODE 0239 IAE ENG: V2527M
1 .06 001 REV040 STD
1656 2341

1 .05 556 REV040 CODE:0038 V2527/2527E
1 .06 001 REV040 STD
0928

1 .05 660 REV040 CODE 0117/V2527/V2527E
1 .06 001 REV040 STD
1566-1648 1773-1895 1957-2097 2121-2288 3071

1 .07 001 REV039 STD
1 .08 101 REV040 CODE 0459
0928

1 .07 100 REV039 27498=31891
1 .08 100 REV040 20343=31276=20343+31276
1656 2341

1 .07 100 REV039 27498=31891
1 .08 101 REV040 CODE 0459
1566

1 .07 100 REV039 27498=31891
1 .08 207 REV040 CODE 0008
1648 1773-2288 3071

1 .09 001 REV040 STD
ALL

1 .09A 001 REV040 STD
ALL

1 .10 290 REV040 M:20268+24044/V2533
1928 2107

1 .10 350 REV040 CODE 0238 IAE ENG: V2527M
1656 2341

1 .10 370 REV040 CODE:0139/V2527/V2527E
0928-1648 1773-1895 1957-2097 2121-2288 3071

1 .11 286 REV040 M:20268+24044/V2533
1 .12 275 REV040 M:20268+24044/V2533
1928 2107

1 .11 350 REV040 CODE 0238 IAE ENG: V2527M
1 .12 350 REV040 CODE 0238 IAE ENG: V2527M
1656 2341

1 .11 370 REV040 CODE:0171/V2527/V2527E
1 .12 356 REV040 CODE:0125/V2527/V2527E
0928-1648 1773-1895 1957-2097 2121-2288

N 1 .11 420 REV040 CODE 106/V2527A5/2527EA5
N 1 .12 356 REV040 CODE:0125/V2527/V2527E
3071

1 .13 001 REV036
1 .14 100 REV040 M:26526
0928-1895 1957

N 1 .13 001 REV036
N 1 .14 150 REV039 CODE 0389
3071

1 .13 001 REV036
1 .14 200 REV040 26526+31375
1928 2097-2341

N 1 .14A 100 REV040 34637
3071

1 .15 105 REV040 CODE 0028
1 .16 025 REV040 CODE 0189
0928

1 .15 105 REV040 CODE 0028
1 .16 033 REV040 V2524/V2522/V2527MA5
1656 2341

1 .15 105 REV040 CODE 0028
1 .16 040 REV040 V2530A5/V2533A5
1928 2107

1 .15 105 REV040 CODE 0028
1 .16 122 REV040 CODE 0190
1566-1648 1773-1895 1957-2097 2121-2288 3071

1 .17 040 REV040 V2500A1/V2527A5/V2527EA5
1 .18 130 REV040 20268/2500/2527/2527EA5
0928

LIST OF EFFECTIVE PAGES (LEP)

M ---PAGE--- SEQ- --REV-- ----VALIDATION CRITERIA-----

M ---PAGE--- SEQ- --REV-- ----VALIDATION CRITERIA-----

-----EFFECTIVITY-----

```

-----
1 .17      110 REV040  CODE 0273
1 .18      118 REV040  20268/V2522/V2524/V2527MA5
                1656 2341

1 .17      144 REV040  CODE 0274/V2500/2527/2527E
1 .18      130 REV040  20268/2500/2527/2527EA5
                1648 1773-1895 1957-2097 2121-2288 3071

1 .17      149 REV040  27498/V2500/2527/2527E
1 .18      130 REV040  20268/2500/2527/2527EA5
                1566

1 .17      214 REV040  CODE 0276
1 .18      117 REV040  20268/V2533
                1928 2107

1 .19      100 REV040  20268/V2522/V2524/2527MA5
1 .20      110 REV040  CODE 0195
                1656 2341

1 .19      103 REV040  20268/V2533
1 .20      214 REV040  CODE 0219
                1928 2107

1 .19      130 REV040  20268/V2500/2527/2527E
1 .20      040 REV040  V2500/27/27E
                0928

1 .19      130 REV040  20268/V2500/2527/2527E
1 .20      144 REV040  CODE 0206
                1648 1773-1895 1957-2097 2121-2288 3071

1 .19      130 REV040  20268/V2500/2527/2527E
1 .20      149 REV040  27498/V2500/27/27E
                1566

1 .21      117 REV040  20268/V2533
1 .22      134 REV040  M:20268/V2533
                1928 2107

1 .21      118 REV040  20268/V2522/V2524/V2527MA5
1 .22      125 REV040  20268/V2522A5/V2524A5/V2527M
                1656 2341

1 .21      130 REV040  20268/2500/2527/2527EA5
1 .22      161 REV040  M:20268/V2500/2527/2527E
                0928-1648 1773-1895 1957-2097 2121-2288 3071

1 .23      201 REV039  CODE 0304
1 .24      202 REV039  CODE 0304
                0928

1 .23      305 REV039  CODE 0302
1 .24      305 REV039  CODE 0302
                1566

1 .23      315 REV039  CODE 0153
1 .24      310 REV039  CODE 0153
                1648-3071

1 .25      001 REV040
                ALL

2 .00      305 REV040  CODE 0445
                0928

2 .00      608 REV040  CODE 0283
                1566-1648 1773-1895 1957-2097 2121-2288

N 2 .00      700 REV040  CODE 0450
                3071

2 .00      708 REV040  CODE 0285
                1928 2107

2 .00      710 REV040  CODE 0310
                1656 2341

2 .00A     001 REV040
                ALL

2 .01      110 REV032  M:24794
2 .02      001 REV039
                ALL

2 .02A     001 REV039  STD
                ALL

2 .02B     001 REV038  CODE 0097
                0928

2 .02B     105 REV038  CODE 0249
                1566-3071

```

LIST OF EFFECTIVE PAGES (LEP)

M ---PAGE--- SEQ- --REV-- ----VALIDATION CRITERIA-----
M ---PAGE--- SEQ- --REV-- ----VALIDATION CRITERIA-----
-----EFFECTIVITY-----

```

2 .03      310 REV040 CODE 0060
2 .04      002 REV038 STD
              0928

2 .03      510 REV040 CODE 0061
2 .04      002 REV038 STD
              1566-1895 1957

2 .03      610 REV040 CODE 0224
2 .04      002 REV038 STD
              1928 2097-3071

2 .05      001 REV032 STD=M:24105
2 .06      001 REV034
              0928-1895 1957-2097 2121-3071

2 .05      210 REV037 CODE 0179
2 .06      001 REV034
              1928 2107

2 .07      001 REV034
2 .08      110 REV039 20024
              0928

2 .07      001 REV034
2 .08      200 REV039 20024+34313=20024+34809
              1566-1895 1957-2097 2121-3071

2 .07      001 REV034
2 .08      210 REV039 CODE 0400
              1928 2107

2 .08A     100 REV039 CODE 0401
              0928

2 .08A     200 REV039 20024+31283
              1566-1895 1957-2097 2121-3071

2 .08A     210 REV039 CODE 0403
              1928 2107

2 .09      100 REV039 20024
              0928-1895 1957-2097 2121-3071

2 .09      200 REV039 20024+22013
              1928 2107

2 .09A     100 REV039 28238
              1656 2341

2 .09A     200 REV039 22013+30422
              1928 2107

2 .09B     100 REV039 28238
              1656 2341

2 .09C     100 REV039 28238
              1656 2341

2 .10      001 REV037 CODE 0422
              0928

2 .10      200 REV040 30368+31283
              1566-3071

2 .10A     001 REV039
              ALL

2 .10B     001 REV037
              ALL

2 .11      110 REV037 M:24645=24645+31283+34864
2 .12      001 REV039
              0928

2 .11      200 REV037 CODE 0424
2 .12      001 REV039
              1566-2341

N 2 .11     301 REV039 M:24645+26925+31283
N 2 .12     001 REV039
              3071

2 .13      001 REV035
2 .14      001 REV040 CODE 0235
              0928

2 .13      001 REV035
2 .14      100 REV040 31283=30660+31283
              1566-3071

2 .15      226 REV040 CODE 409 V2533A5
2 .16      119 REV040 CODE 0410
              1928 2107

```

LIST OF EFFECTIVE PAGES (LEP)

M ---PAGE--- SEQ- --REV-- ----VALIDATION CRITERIA-----

M ---PAGE--- SEQ- --REV-- ----VALIDATION CRITERIA-----

-----EFFECTIVITY-----

```

-----
2 .15      228 REV040 CODE 409 2522/2524/2527MA5
2 .16      119 REV040 CODE 0410
                1656 2341

2 .15      230 REV040 CODE 409 2527/2527EA5
2 .16      119 REV040 CODE 0410
                0928-1648 1773-1895 1957-2097 2121-2288 3071

2 .17      119 REV040 CODE 0246
2 .18      126 REV040 20268/V2533-A5
                1928 2107

2 .17      119 REV040 CODE 0246
2 .18      130 REV040 20268/V2527A5/27E
                0928-1648 1773-1895 1957-2097 2121-2288 3071

2 .17      205 REV040 CODE 0230
2 .18      128 REV040 20268/V2522/24/27M
                1656 2341

2 .18A     126 REV040 20268/V2533-A5
                1928 2107

2 .18A     128 REV040 20268/V2522/24/27M
                1656 2341

2 .18A     130 REV040 20268/V2527A5/27E
                0928-1648 1773-1895 1957-2097 2121-2288 3071

2 .19      215 REV040 CODE 0068
2 .20      001 REV040
                0928

2 .19      300 REV040 CODE 0131
2 .20      001 REV040
                1566-1648 1773-2288

2 .19      300 REV040 CODE 0131
2 .20      102 REV040 M:24105
                1656 2341

N 2 .19     308 REV040 CODE 0130
N 2 .20     200 REV040 31105+35220=31070+35220
                3071

2 .21      001 REV036 STD
2 .22      050 REV037 CODE:0011
                0928

2 .21      100 REV036 CODE 0199
2 .22      050 REV037 CODE:0011
                1566-3071

2 .23      035 REV037 IAE
2 .24      035 REV035 CODE 0011
                ALL

2 .25      090 REV037 IAE V2533
2 .26      115 REV040 22013
                1928 2107

2 .25      113 REV039 28238/IAE V2527M
2 .26      001 REV040 STD=24105
                1656 2341

2 .25      348 REV038 CODE 0456/V2527
2 .26      001 REV040 STD=24105
                0928-1648 1773-1895 1957-2097 2121-2288 3071

2 .27      001 REV035
2 .28      001 REV035
                ALL

2 .29      001 REV040 STD
2 .30      001 REV040 STD
                ALL

2 .30A     001 REV040 STD
                ALL

2 .31      130 REV037 CODE 0036
2 .32      001 REV040 STD={20139+22129}
                0928

2 .31      146 REV036 20268/IAE V2527M
2 .32      105 REV040 M:24105
                1656 2341

2 .31      150 REV036 20268/IAE V2533
2 .32      106 REV039 M:22013
                1928 2107

2 .31      235 REV037 20268+25225/V2500/2527/2527E
2 .32      001 REV040 STD={20139+22129}
                1566-1648 1773-1895 1957-2097 2121-2288 3071

```

LIST OF EFFECTIVE PAGES (LEP)

M ---PAGE--- SEQ- --REV-- ----VALIDATION CRITERIA-----

M ---PAGE--- SEQ- --REV-- ----VALIDATION CRITERIA-----

-----EFFECTIVITY-----

```

2 .32A 001 REV039 STD
          0928-1648 1773-1895 1957-2097 2121-2288
N 2 .32A 101 REV039 M:26925
          3071
2 .32A 102 REV039 M:22013
          1928 2107
2 .32A 103 REV039 M:24105
          1656 2341
2 .33 001 REV040 STD=20139+22129
2 .34 001 REV040
          0928-1648 1773-1895 1957-2097 2121-2288 3071
2 .33 110 REV040 22013
2 .34 001 REV040
          1928 2107
2 .33 115 REV040 24105
2 .34 001 REV040
          1656 2341
2 .35 001 REV035
2 .36 001 REV040 STD = 26792+28488
          ALL
2 .37 001 REV039
2 .38 001 REV040 CODE 0095
          0928-1648 1773-1895 1957-2097 2121-2288
2 .37 100 REV039 22013=22013+33100+34997
2 .38 001 REV040 CODE 0095
          1928 2107
2 .37 102 REV039 CODE 0428
2 .38 001 REV040 CODE 0095
          1656 2341
N 2 .37 255 REV040 M:24771+33100
N 2 .38 205 REV040 M.(33100+32650)=(33300+32650
          3071
2 .39 200 REV037 CODE 0207
2 .40 100 REV036 CODE 0154
          0928
2 .39 300 REV039 CODE 0142
2 .40 300 REV037 CODE 0040
          1656
2 .39 300 REV039 CODE 0142
2 .40 305 REV037 CODE 0041
          1566-1648 1773-1895 1957-2097 2121-2341
2 .39 300 REV039 CODE 0142
2 .40 410 REV038 CODE 0046
          1928 2107
N 2 .39 400 REV039 CODE 0141
N 2 .40 305 REV037 CODE 0041
          3071
2 .41 030 REV036 IAE
2 .42 001 REV039 STD
          ALL
2 .43 143 REV040 20268/V2527/V2527E
          0928-1648 1773-1895 1957-2097 2121-2288 3071
2 .43 145 REV040 20268/V2527M
          1656 2341
2 .43 148 REV040 20268/V2533
          1928 2107
3 .00 001 REV024
          ALL
3 .01 200 REV038 CODE 0380
3 .02 001 REV034 STD OR M:(26358+30980)
          0928
3 .01 200 REV038 CODE 0380
3 .02 205 REV037 M:26358+27620
          1566-2341
N 3 .01 300 REV038 CODE 0381
N 3 .02 205 REV037 M:26358+27620
          3071
3 .03 001 REV039
3 .04 001 REV039 STD=M:22013+24044
          ALL

```

LIST OF EFFECTIVE PAGES (LEP)
M ---PAGE--- SEQ- --REV-- ----VALIDATION CRITERIA-----
M ---PAGE--- SEQ- --REV-- ----VALIDATION CRITERIA-----
-----EFFECTIVITY-----

```

3 .05      001  REV039  CODE 0382
3 .06      001  REV039
              0928

3 .05      103  REV039  26358-(26358+37620)
3 .06      001  REV039
              1566-1648 1773-1895 1957-2097 2121-2288 3071

3 .05      103  REV039  26358-(26358+37620)
3 .06      105  REV039  22013
              1928 2107

3 .05      203  REV039  CODE 0383
3 .06      001  REV039
              1656 2341

3 .07      001  REV039
3 .08      001  REV039
              0928-1895 1957-2097 2121-3071

3 .07      105  REV039  22013
3 .08      105  REV039  22013
              1928 2107

3 .09      100  REV036  25863
3 .10      001  REV039
              ALL

4 .00      001  REV024
              ALL

4 .01      130  REV025  M:20268 V2500/V2527/V2527E
4 .02      330  REV037  CODE:0171/V2527A5/EAS
              0928-1648 1773-1895 1957-2097 2121-2288 3071

4 .01      153  REV029  M:20268 IAE V2527M
4 .02      305  REV037  CODE 0204 IAE ENG: V2527M
              1656 2341

4 .01      160  REV031  M:20268/IAE V2533
4 .02      240  REV036  20268+24044/IAE V2533
              1928 2107

4 .03      240  REV036  20268+24044/IAE V2533
4 .04      230  REV036  20268+24044 IAE V2533
              1928 2107

4 .03      305  REV037  CODE 0204 IAE ENG: V2527M
4 .04      305  REV037  CODE 0204 IAE ENG: V2527M
              1656 2341

4 .03      330  REV037  CODE:0171/V2527A5/EAS
4 .04      330  REV037  CODE:0171/V2527E/A5
              0928-1648 1773-1895 1957-2097 2121-2288 3071

4 .05      120  REV037  M:20268/V2527/V2527E/T=L
4 .06      140  REV032  M:20268/IAE V2527/V2527E
              0928-1648 1773-1895 1957-2097 2121-2288 3071

4 .05      126  REV030  M:20268/IAE V2527M/T OR L
4 .06      225  REV030  M:20268+28238/IAE V2527M
              1656 2341

4 .05      155  REV037  M:20268/IAE V2533/T=L
4 .06      155  REV036  M:20268/IAE V2533
              1928 2107

4 .07      140  REV032  M:20268/IAE V2527/V2527E
4 .08      140  REV026  M:20268 IAE V2527/V2527E
              0928-1648 1773-1895 1957-2097 2121-2288 3071

4 .07      145  REV028  M:20268/IAE V2527M
4 .08      145  REV028  M: 20268/V2527M
              1656 2341

4 .07      155  REV036  M:20268/IAE V2533
4 .08      155  REV028  M:20268/IAE V2533
              1928 2107

4 .09      140  REV035  20268 IAE V2527/V2527E/T=L
4 .10      140  REV026  M:20268 IAE V2527/V2527E
              0928-1648 1773-1895 1957-2097 2121-2288 3071

4 .09      155  REV035  20268 IAE V2533/T=L
4 .10      155  REV025  M:20268 IAE V2533
              1928 2107

4 .09      290  REV035  20268+28238/IAE V2527M/T=L
4 .10      285  REV030  M:20268+28238/IAE V2527M
              1656 2341

4 .11      020  REV038  IAE V2530/V2533
4 .12      155  REV025  M:20268 IAE V2533
              1928 2107

```

LIST OF EFFECTIVE PAGES (LEP)

M ---PAGE--- SEQ- --REV-- ----VALIDATION CRITERIA-----

M ---PAGE--- SEQ- --REV-- ----VALIDATION CRITERIA-----

-----EFFECTIVITY-----

```

4 .11      025 REV038 IAE V2527A5/2527EA5
4 .12      140 REV026 M:20268 IAE V2527/V2527E
              0928-1648 1773-1895 1957-2097 2121-2288 3071

4 .11      135 REV038 CODE 0098 2522/24/27M/27A
4 .12      275 REV030 M:20268+28238/V2527M
              1656 2341

4 .13      140 REV030 M:20268 IAE V2527/V2527E
4 .14      140 REV033 M:20268 IAE V2527/V2527E
              0928-1648 1773-1895 1957-2097 2121-2288 3071

4 .13      145 REV030 M:20268 IAE V2527M
4 .14      190 REV033 M:20268 IAE V2527M
              1656 2341

4 .13      155 REV030 M:20268 IAE V2533
4 .14      155 REV033 M:20268/IAE V2533
              1928 2107

4 .15      001 REV024
4 .16      001 REV024
              ALL

5 .00      001 REV035
              ALL

5 .01      110 REV039 CODE 0143
5 .02      100 REV025 M:22013=24105=26334=26335
              1928 2107

5 .01      150 REV039 MOD:20268 IAE V2527/V2527E
5 .02      100 REV025 M:22013=24105=26334=26335
              0928-1648 1773-1895 1957-2097 2121-2288

N 5 .01      150 REV039 MOD:20268 IAE V2527/V2527E
N 5 .02      110 REV037 26925
              3071

5 .01      190 REV039 MOD:20268 IAE V2527M
5 .02      100 REV025 M:22013=24105=26334=26335
              1656 2341

5 .03      100 REV024 M:22013=24105=26334=26335
5 .04      001 REV038
              ALL

7 .00      001 REV040 STD
              ALL

7 .01      105 REV040 CODE 0325
              0928-1648 1773-1895 1957-2097 2121-2288 3071

7 .01      212 REV040 CODE 0326
              1928 2107

7 .01      320 REV040 CODE 0427
              1656 2341

```

M

V	REV	MOD	MP	TITLE	VALIDITY
T		SB			
.	040A				
	28-1152			A7-ABR	A7-ADA A7-ADB
	28-1153			A7-CJA	A7-ADC A7-ADD
	36-1049			A7-ADS	A7-ADE A7-ADF
				A7-ADT	A7-ADG A7-ADH
				A7-ADI	A7-ADJ A7-CJB
.	040A			A7-CJB	
.	039			PNEUMATIC - ENGINE BLEED AIR SUPPLY SYSTEM - INSPECTION OF BLEED SYSTEM TEMPERATURE CONTR L THERMOSTAT	
				A7-ABR	A7-ADA A7-ADB
				A7-CJA	A7-ADC
.	026A 20024			FUEL- INSTALL A CENTRE TANK SYSTEM- ALL	
.	036 20059			AIR CONDITIONING - CARGO COMPARTMENT - VENTILATION - INSTALL SYSTEM IN AFT COMPARTMENT -	
				A7-ABR	A7-ADA A7-ADB
				A7-ADC	A7-ADD A7-ADS
				A7-ADE	A7-ADF A7-ADT
				A7-ADG	A7-ADH A7-ADI
				A7-ADJ	MSN 3071
.	037 20063			OXYGEN - FLIGHT CREW SYSTEM - INSTALL A 77.1 CU/FT BOTTLE IN COMPOSITE MATERIAL - ALL	
.	037 20151			OXYGEN - FLIGHT CREW OXYGEN - INSTALL A 115 CU/FT STEEL OXYGEN CYLINDER -	
				A7-ABR	A7-ADA A7-ADB
				A7-ADC	A7-ADD A7-ADS
				A7-ADE	A7-ADF A7-ADT
				A7-ADG	A7-ADH A7-ADI
				A7-ADJ	A7-CJB MSN 3071
.	026A 20268			WINGS-WING TIP FENCES-INTRODUCE WING TIPS INCLUDING FENCES- ALL	

M

V REV MOD MP TITLE
T SB VALIDITY

- . 026A 21285 ENGINE CONTROLS-MODIFY POWER SUPPLY
..... FOR HP FUEL SOLENOID
ALL

- . 026A 21678 ELECTRICAL POWER-AC/DC ESSENTIAL POWER
..... DISTRIBUTION-PROVIDE PROVISIONS FOR
ETOPS-
ALL

- . 026A 21706 AIR CONDITIONING - VENTILATION CONT.
..... ISOLATION VALVES - CHANGE POWER SUPPLY
FOR ETOPS -
A7-ABR A7-ADA A7-ADB
A7-ADC A7-ADD A7-ADS
A7-ADE A7-ADF A7-ADT
A7-ADG A7-ADH A7-ADI
A7-ADJ MSN 3071

- . 026A 21768 AIR CONDITIONING - PROVIDE EMERGENCY
..... POWER SUPPLY FOR AFT CARGO COMPT
HEATING CONTROLLER FOR EROPS -
A7-ABR A7-ADA A7-ADB
A7-ADC A7-ADD A7-ADS
A7-ADE A7-ADF A7-ADT
A7-ADG A7-ADH A7-ADI
A7-ADJ MSN 3071

- . 026A 21858 COMMUNICATIONS - INSTALL HF1 FOR EROPS
..... ALL

- . 036B 22013 FUSELAGE - REAR FUSELAGE SECTION 16A -
..... DEFINE A321 BASIC STRUCTURE
A7-ADS A7-ADT

- . 026A 22536 NAVIGATION - INSTALL A BENDIX TCAS II
..... COLLISION AVOIDANCE SYSTEM
A7-ABR A7-ADA A7-ADB
A7-CJA A7-ADC A7-ADD
A7-ADS A7-ADE A7-ADF
A7-ADT A7-ADG A7-ADH
A7-ADI A7-ADJ A7-CJB

- . 026A 22562 AIRBORNE AUXILIARY POWER UNIT -
..... INTRODUCE APIC APS-3200
ALL

M

V	REV	MOD	MP	TITLE	VALIDITY
T		SB			
.	026A	23008	POWER PLANT - IAE - INSTALL DERATED V2500-A5 ON A320 A/C	
				A7-ABR	A7-ADA
				A7-ADC	A7-ADD
				A7-ADF	A7-ADG
				A7-ADI	A7-ADJ
					MSN 3071
.	026A	23208	LANDING GEAR - WHEELS AND BRAKES - INTRODUCE BSCU STD 6	
				ALL	
N	040B	23227	NAVIGATION - INSTALL A TCAS II COLLISION AVOIDANCE SYSTEM (HONEYWELL)	
				MSN 3071	
.	026A	23901	LANDING GEAR - WHEELS AND BRAKES - INTRODUCE MODIFIED ALTERNATE BRAKE DISTRIBUTION DUAL VALVE	
				ALL	
.	036B	24044	LANDING GEAR - WHEELS AND BRAKES - INSTALL MESSIER GOODRICH WHEELS AND BRAKES ON A321	
				A7-ADS	A7-ADT
.	035A	24105	FUSELAGE - REAR FUSELAGE - ADAPT SECTION 17/19 STRUCTURE TO A319 DEFINITION	
				A7-CJA	A7-CJB
.	026A	24215	AUTO FLIGHT - FAC - INSTALL TWO FACS P/N BAM 0509	
				ALL	
.	026A	24588	AUTO FLIGHT-FAC-INTRODUCE FAC P/N BAM 510	
				ALL	
.	029	24645	LANDING GEAR-MLG-LGCIU-INTRODUCTION OF STANDARD UNIT P/N A4C	
				ALL	

M

V	REV	MOD	MP	TITLE	VALIDITY	
T		SB				
.	026A	24701	HYDRAULIC POWER-AUXILIARY HYDRAULIC POWER-RAT-INTRODUCE MODIFIED RAT (NEW BEARING)		
				A7-ABR	A7-ADA	A7-ADB
				A7-ADC	A7-ADD	A7-ADE
				A7-ADF	A7-ADG	A7-ADH
				A7-ADI	A7-ADJ	MSN 3071
.	036	24771	COMMUNICATIONS-CIDS-INTRODUCE MODIFIED DIRECTOR POWER SUPPLY PRINCIPLE		
				A7-CJA	A7-CJB	MSN 3071
.	036	24785	NAVIGATION-ADIRS-INTRODUCE 4MCU ADIRU HONEYWELL P/N C06		
				A7-ADA	A7-ADB	A7-ADC
				A7-ADD	A7-ADE	A7-ADF
				A7-ADG	A7-ADH	A7-ADI
				A7-ADJ		MSN 3071
.	026A	24794	AIR CONDITIONING-COCKPIT AND CABIN TEMPERATURE CTRL-INTRODUCE MODIFIED TEMPERATURE SENSOR P/N-02.0N MIXER UNIT ALL		
.	034	24946	LANDING GEAR - MLG - MESSIER - INTRODUCE BRAKES P/N C202253		
				A7-ABR	A7-ADA	A7-ADB
				A7-CJA	A7-ADC	A7-ADD
				A7-ADE	A7-ADF	A7-ADG
				A7-ADH	A7-ADI	A7-ADJ
				A7-CJB		MSN 3071
.	036A	25108	NAVIGATION - ADIRS - INSTALL ADIRS LITTON 4MCU ON A320		
				A7-ABR	A7-ADA	A7-ADB
				A7-ADC	A7-ADD	A7-ADE
				A7-ADF	A7-ADG	A7-ADH
				A7-ADI		
.	032A	25225	AUTO FLIGHT-FMGC-REDUCE VAPP FOR A320 CFM/IAE		
				A7-ADA	A7-ADB	A7-ADC
				A7-ADD	A7-ADE	A7-ADF
				A7-ADG	A7-ADH	A7-ADI
				A7-ADJ		MSN 3071

M

V	REV	MOD	MP	TITLE	VALIDITY
T		SB			
.	038A	25294	NAVIGATION - ADIRS - INSTALL HONEYWELL ADIRS CAPABLE OF A319 A/C A7-CJB	
.	031	25404	EXHAUST-THRUST REVERSER CONTROL AND INDICATING-ACTIVATE ADDITIONAL THRUST REVERSER LOCK CONTROL ALL	
.	026A	25419	ICE AND RAIN PROTECTION-WINDSHIELD RAIN PROTECTION-DEACTIVATION OF RAIN REPELLENT SYSTEM ALL	
.	036B	25643	POWER PLANT - GENERAL - INSTALL IAE V2533-A5 ENGINE ON A321-231 RATED AT 33000 LBS A7-ADS A7-ADT	
.	039	25819	NAVIGATION - WEATHER RADAR SYSTEM - ACTIVATE DUAL PREDICTIVE WINDSHEAR FUNCTION	
		34-1176	05		
				A7-ABR	A7-ADA A7-ADB
				A7-CJA	A7-ADC A7-ADD
				A7-ADS	A7-ADE A7-ADF
				A7-ADT	A7-ADG A7-ADH
				A7-ADI	A7-ADJ A7-CJB
.	029A	25863	AUTO FLIGHT - FCU - DEFINE FLIGHT DIRECTOR ENGAGEMENT IN CROSSED BARS AT GO AROUND ALL	
		22-1058	40		
N	040B	26117	NAVIGATION - WEATHER RADAR SYSTEM - ACTIVATE COLLINS DUAL PREDICTIVE WINDSHEAR SYSTEM MSN 3071	
.	026A	26335	FLIGHT CONTROLS-GENERAL - DELETION OF L.A.F. FEATURE FROM A320 A/C (SERIAL SOLUTION)	
				A7-ABR	A7-ADA A7-ADB
				A7-ADC	A7-ADD A7-ADE
				A7-ADF	A7-ADG A7-ADH
				A7-ADI	A7-ADJ MSN 3071

M

V	REV	MOD	MP	TITLE	VALIDITY
T		SB			
.	037	26358	AUTOFLIGHT-FLIGHT CONTROL UNIT- (FCU) INTRODUCE SEXTANT MODULAR FCU	
				A7-ADA	A7-ADB A7-CJA
				A7-ADC	A7-ADD A7-ADS
				A7-ADE	A7-ADF A7-ADT
				A7-ADG	A7-ADH A7-ADI
				A7-ADJ	A7-CJB MSN 3071
.	026A	26526	NAVIGATION - GPWS - ACTIVATE ENHANCED FUNCTIONS OF THE EGPWS ALL	
.	035	26728	INDICATING/RECORDING SYSTEM - FWC - INTRODUCE FWC STANDARD H2E2	
				A7-ADA	A7-ADB A7-CJA
				A7-ADC	A7-ADD A7-ADS
				A7-ADE	A7-ADF A7-ADT
				A7-ADG	A7-ADH A7-ADI
				A7-ADJ	A7-CJB MSN 3071
.	037	26792	AIR CONDITIONING-PACK TEMPERATURE CTRL- INTRODUCE MODIFIED PACK TEMPERATURE CONTROLLER ALL	
.	033	26910	FLIGHT CONTROL -ELAC SYSTEM- INTRODUCE E.L.A.C. WITH ENHANCED RELAYS	
				A7-ADA	A7-ADB A7-CJA
				A7-ADC	A7-ADD A7-ADS
				A7-ADE	A7-ADF A7-ADT
				A7-ADG	A7-ADH A7-ADI
				A7-ADJ	A7-CJB MSN 3071
N	040B	26925	LANDING GEAR-ALTERNATE BRAKING- INTRODUCE MODIFIED ALTERNATE BRAKING SYSTEM MSN 3071	
.	036	26965	LANDING GEAR-WHEELS AND BRAKES- INTRODUCE BSCU COMMON STD	
				A7-ADG	A7-ADH A7-ADI
				A7-ADJ	A7-CJB MSN 3071

M

V	REV	MOD	MP	TITLE	VALIDITY	
T		SB				
.	030A	26999	NAVIGATION - MMR - INSTALL COLLINS MMR PROVIDING ILS AND GPS FUNCTION		
		34-1162	07	ALL		
.	033	27276	FLIGHT CONTROLS-ELAC SYSTEM-INTRODUCE ELAC SOFTWARE "L80"		
				ALL		
.	035	27498	ELECTRICAL POWER - GENERAL - AC-DC MAIN DISTRIBUTION - INSTALL AC-DC SHEDDABLE BUSBARS		
				A7-ADA	A7-ADB	A7-CJA
				A7-ADC	A7-ADD	A7-ADS
				A7-ADE	A7-ADF	A7-ADT
				A7-ADG	A7-ADH	A7-ADI
				A7-ADJ	A7-CJB	MSN 3071
.	037	27522	INFORMATION SYSTEM - AIR TRAFFIC AND INFORMATION SYSTEM (ATIMS) - INSTALL ATSU COMPUTER FOR ACARS		
				A7-ADA	A7-ADB	A7-CJA
				A7-ADC	A7-ADD	A7-ADS
				A7-ADE	A7-ADF	A7-ADT
				A7-ADG	A7-ADH	A7-ADI
				A7-ADJ	A7-CJB	MSN 3071
.	035A	27568	POWER PLANT-GENERAL-INTRODUCE THIRD RATING ON IAE ENGINES V2527-M-A5 FOR A319 A/C		
				A7-CJA	A7-CJB	
.	036	27620	NAVIGATION-STANDBY DATA : ALTITUDE AND HEADING - INSTALL INTEGRATED STANDBY INSTRUMENT SYSTEM (ISIS)		
		34-1261	11	A7-ADA	A7-ADB	A7-CJA
				A7-ADC	A7-ADD	A7-ADS
				A7-ADE	A7-ADF	A7-ADT
				A7-ADG	A7-ADH	A7-ADI
				A7-ADJ	A7-CJB	MSN 3071

M

V REV	MOD MP	TITLE		
T	SB		VALIDITY	

. 034 27624 EQUIPMENT/FURNISHINGS-MISCELLANEOUS
 23-1157 18 EMERGENCY EQUIPMENT-INSTALL ELT CEIS
 AO6V2 WITH CONTROL PANEL IN COCKPIT

A7-ABR	A7-ADA	A7-ADB
A7-CJA	A7-ADC	A7-ADD
A7-ADS	A7-ADE	A7-ADF
A7-ADT	A7-ADG	A7-ADH
A7-ADI	A7-ADJ	A7-CJB

N 040B 27646 NAVIGATION - MMR - INSTALL SEXTANT MMR
 PROVIDING ILS (FM IMMUNE)
 MSN 3071

. 030B 27698 NAVIGATION - TCAS - INSTALL ALLIED
 34-1177 16 SIGNAL TCAS COMPUTER P/N 066-50000-2220
 (WITH CHANGE 7.0)

A7-ABR	A7-ADA	A7-ADB
A7-CJA	A7-ADC	A7-ADD
A7-ADS	A7-ADE	A7-ADF
A7-ADT	A7-ADG	A7-ADH
A7-ADI	A7-ADJ	A7-CJB

. 033 27773 LANDING GEAR-NORMAL BRAKING-
 32-1232 01 INTRODUCE STD 8 BSCU (TWIN
 VERSION)
 ALL

. 033 27845 FLIGHT CONTROLS-ELAC-INTRODUCE
 ELAC WITH ADVANCED ELAC POWER SUPPLY
 BOARD

A7-ADA	A7-ADB	A7-CJA
A7-ADC	A7-ADD	A7-ADS
A7-ADE	A7-ADF	A7-ADT
A7-ADG	A7-ADH	A7-ADI
A7-ADJ	A7-CJB	MSN 3071

. 038A 27846 AUTOFLIGHT-FAC-INTRODUCE FAC STD P/N
 BAM0514
 A7-CJB

M

V	REV	MOD	MP	TITLE	VALIDITY
T		SB			
.	032A	28160	ELEC PWR-AC EMERGENCY GENERATION- ACTIVATE A319/A321 ELECTRICAL EMERGENCY CONFIGURATION ON A320 A/C	
		A7-ADA		A7-ADB	A7-ADC
		A7-ADD		A7-ADE	A7-ADF
		A7-ADG		A7-ADH	A7-ADI
		A7-ADJ		MSN 3071	
.	034	28164	LANDING GEAR - WHEELS AND BRAKES - INSTALL CARBON BRAKES TYPE SEPCARB III PLUS - MESSIER BUGATTI	
		A7-ADA		A7-ADB	A7-CJA
		A7-ADC		A7-ADD	A7-ADE
		A7-ADF		A7-ADG	A7-ADH
		A7-ADI		A7-ADJ	A7-CJB
		MSN 3071			
.	036A	28218	NAVIGATION-ADIRS-INTRODUCE LITTON ADIRU 4 MCU STD-312	
		34-1181	04		
		A7-ABR		A7-ADA	A7-ADB
		A7-CJA		A7-ADC	A7-ADD
		A7-ADS		A7-ADE	A7-ADF
		A7-ADT		A7-ADG	A7-ADH
		A7-ADI		A7-CJB	
.	035A	28238	FUEL - GENERAL - A319 CORPORATE JET - ACT FLEXIBILITY CONCEPT (0 TO 6)	
		A7-CJA		A7-CJB	
.	035A	28342	GENERAL-A319 CJ MODIFY CHARACTERISTICS GROUND/FLIGHT C.G. LIMIT (TO FWD) AND ADAPT GREEN BAND ON PITCH TRIM WHEEL	
		A7-CJA		A7-CJB	
N	040B	28382	NAVIGATION - MMR - ACTIVATE GPS PRIMARY FUNCTION (HYBRID) IN SEXTANT MMR (WITH HONEYWELL OR LITTON ADIRU)	
		MSN 3071			
.	032A	28479	INDICATING RECORDING SYSTEM-FWC- INTRODUCE FWC STANDARD H2/E3P	
		A7-ADA		A7-ADB	A7-CJA
		A7-ADC		A7-ADD	A7-ADS
		A7-ADE		A7-ADF	A7-ADT
		A7-ADG		A7-ADH	A7-ADI
		A7-ADJ		A7-CJB	MSN 3071

M

V	REV	MOD	MP	TITLE	VALIDITY
T		SB			
.	037	28488	AIR CONDITIONING-PACK TEMP.CTRL INTRODUCE MODIFIED PACK TEMP. CTRL P/N 759D0000-02 ALL	
		21-1118			
N	040B	28495	NAVIGATION - MMR - REMOVE COLLINS MMR PROVIDING ILS (FM IMMUNE) AND GPS PRIMARY FUNCTION (PREVIOUS SPEC.) MSN 3071	
N	040B	28738	NAVIGATION - TCAS - INSTALL HONEYWELL COMPUTER TCAS 2000 CHANGE 7.0 WITH HONEYWELL ATC MSN 3071	
.	036B	28960	GENERAL - DESIGN WEIGHT - INCREASE A321-200 DESIGN WEIGHT TO 93,0T MTOW 77,8T MLW AND 73,8T MZFW (W.V. 001) A7-ADS A7-ADT	
.	031	30163	NAVIGATION-TCAS-INSTALL ALLIED SIGNAL COMPUTER P/N 066-50000-2120 (WITH CHANGE 7.0) WITHOUT DATA LOADER A7-ABR	
.	035A	30368	INDICATING RECORDING SYSTEMS- EIS-INSTALL DMC, DU AND DISKETTES FOR EIS2 A7-ADA A7-ADB A7-CJA A7-ADC A7-ADD A7-ADS A7-ADE A7-ADF A7-ADT A7-ADG A7-ADH A7-ADI A7-ADJ A7-CJB MSN 3071	
		31-1193			
.	036B	30422	FUEL-CERTIFICATION OF FUEL SYSTEM- (LOW PRESSURE SYSTEM) FOR THE OPERATION 0 TO 2 ACTS A7-ADS A7-ADT	
.	036	30439	AUTO-FLIGHT-FLIGHT AUGMENTATION COMPUTER-INTRODUCE FAC SOFTWARE STANDARD P/N B397BAM0515 A7-CJA A7-ADS A7-ADT A7-CJB MSN 3071	

M

V REV MOD MP TITLE
T SB VALIDITY

- N 040B 30626 AIR CONDITIONING-AIR COOLING-
..... INSTALL A NEW ECS
MSN 3071

- . 039 30660 INDICATING/RECORDING SYSTEMS - FWC -
..... INSTALL FWC STANDARD H2E4
A7-ADA A7-ADB A7-CJA
A7-ADC A7-ADD A7-ADS
A7-ADE A7-ADF A7-ADT
A7-ADG A7-ADH A7-ADI
A7-ADJ A7-CJB MSN 3071

- . 035A 30884 PNEUMATIC-ENGINE BLEED AIR SUPPLY-
..... INTRODUCE MODIFIED TEMPERATURE CONTROL
THERMOSTAT (TCT)
A7-ADD A7-ADS A7-ADE
A7-ADF A7-ADT A7-ADG
A7-ADH A7-ADI A7-ADJ
A7-CJB MSN 3071

- . 036 30941 NAVIGATION-ADIRU-INSTALL HONEYWELL ADIR
..... U 4 MCU AD11 (NEW HARD)
A7-ADA A7-ADB A7-ADC
A7-ADD A7-ADE A7-ADF
A7-ADG A7-ADH A7-ADI
A7-ADJ A7-CJB MSN 3071

- . 040 31070 NAVIGATION-ADIRS-INSTALL LITTON ADIRU
..... 4 MCU STANDARD 0314
(A318 COEFF CFM ADDED)
A7-CJB

- . 040 31105 NAVIGATION - ADIRS - INSTALL HONEYWELL
..... ADIRU 4MCU P/N HG2030AE21
(A318 COEFF CFM ADDED)
A7-ADJ MSN 3071

- . 036A 31106 LANDING GEAR - NORMAL BRAKING -
32-1232 01 INTRODUCE STD 9 BSCU (TWIN VERSION)
ALL

- N 040B 31152 LANDING GEAR-STEERING-SUPPLY NOSE
..... WHEEL STEERING WITH YELLOW HYDRAULIC
POWER IN PLACE OF GREEN HYDRAULIC POWER
MSN 3071

M

V	REV	MOD	MP	TITLE	VALIDITY
T		SB			
.	035A	31897		AUTOFLIGHT-FMGC-INSTALL FMGC IAE C13042BA01 (EQUIPPED WITH FMS2 HONEYWELL)	
				A7-CJA	A7-ADS A7-ADE
				A7-ADF	A7-ADT A7-ADG
				A7-ADH	A7-ADI A7-ADJ
				A7-CJB	MSN 3071
.	037C	32087		COMMUNICATIONS-ANTI HIJACK CAMERA MONITORING-INSTALL A COCKPIT DOOR SURVEILLANCE SYSTEM	
				A7-ADA	A7-ADB A7-CJA
				A7-ADC	A7-ADD A7-ADS
				A7-ADE	A7-ADF A7-ADT
				A7-ADG	A7-ADH A7-ADI
				A7-ADJ	A7-CJB MSN 3071
.	037C	32088		EQUIPMENT FURNISHINGS-CURTAINS AND PARTITIONS-MODIFIED INTRUSION AND PENETRATION RESISTANT COCKPIT DOOR ALL	
		25-1287	05		
		25-1305	06		
.	035A	32090		DOORS-PASSENGER COMPARTMENT FIXED INTERIOR DOORS-INSTALL ELECTRICAL COCKPIT DOOR RELEASE SYSTEM ALL	
		25-1287	05		
		25-1305	06		
.	039	32333		AUTOFLIGHT-FMGC-RE-INSTALL FMS1 IAE P/N B546CCM0105 (ANTI MOD 31897) (IAE GPS+ACARS) A7-ADE	
.	036	32401		AUTOFLIGHT - FMGC DEFINE AND INSTALL FMGC IAE C13043BA01 THALES(EQUIPPED WITH FMS2 THALES/SMITH)	
		22-1161			
				A7-CJA	A7-ADS A7-ADF
				A7-ADT	A7-ADG A7-ADH
				A7-ADI	A7-ADJ A7-CJB
					MSN 3071
.	036	32499		DOORS - PASSENGER COMPARTMENT FIXED INTERIOR DOORS - INSTALL ELECTRICAL OVERRIDE SYSTEM	
				A7-ADS	A7-ADF A7-ADT
				A7-ADG	A7-ADH A7-ADI
				A7-ADJ	A7-CJB MSN 3071

M

V REV MOD MP TITLE
T SB VALIDITY

N 040B 32650 FUEL - QUANTITY INDICATION -
..... INTRODUCE FUEL LEAK DETECTION
MSN 3071

. 037A 32929 AUTOFLIGHT-FMGC-INSTALL NEW THALES FMGC
22-1116 04 2ND GENERATION EQUIPED WITH FMS2 SMITH
(REV 01) ON A/C FITTED WITH IAE ENGINES
A7-ADA A7-ADB A7-ADC
A7-ADD A7-ADE

N 040B 33100 COMMUNICATIONS-CIDS-INTRODUCE ENHANCED
..... CIDS (A318 VERSION) AND RELATED SYSTEMS
ON SINGLE AISLE FAMILY
MSN 3071

. 039A 33376 LANDING GEAR - NORMAL BRAKING -
..... INSTALL BSCU STD L4.5
A7-ADS A7-ADT A7-ADG
A7-ADH A7-ADI A7-ADJ
A7-CJB MSN 3071

. 039 33879 FLIGHT CONTROLS - ELAC SYSTEM - INSTALL
27-1151 01 ELAC L83 SOFTWARE
- RETROFIT ONLY
A7-ADS A7-ADT

. 039 34043 FLIGHT CONTROLS - ELAC SYSTEM -
27-1152 02 INSTALL ELAC L91 SOFTWARE
A7-ADS A7-ADT MSN 3071

. 038A 34145 COMMUNICATIONS - ANTI HIJACK CAMERA
..... MONITORING - REPLACE HINGE ASSY FOR
CDSS LCD/SYSTEM CONTROLLER
A7-ADJ A7-CJB MSN 3071

N 040B 34330 EQUIPMENT/FURNISHINGS-MISCELLANEOUS
..... EMERGENCY EQUIPMENT-INSTALL ELT WITH
RCP IN COCKPIT ON ENH. PROV. - ELTA
MSN 3071

M

V REV	MOD	MP	TITLE	VALIDITY
T	SB			
. 038A	34571	INDICATING/RECORDING SYSTEMS-ELECTRONIC	
	31A1220	01	INSTRUMENT SYSTEM(EIS)- INSTALL DISPLAY	
			MANAGEMENT COMPUTER SOFTWARE EIS2 S4-2	
			A7-ADA	A7-ADB A7-CJA
			A7-ADC	A7-ADD A7-ADS
			A7-ADE	A7-ADF A7-ADT
			A7-ADG	A7-ADH A7-ADI
			A7-ADJ	A7-CJB MSN 3071

N 040B	34637	NAVIGATION- T2CAS- INSTALL ACSS TRAFFIC	
		AND TERRAIN COLLISION AVOIDANCE SYSTEM	
			(T2CAS)	
			MSN 3071	

. 039C	34809	AUTO-FLIGHT - FLIGHT MANAGEMENT AND	
		GUIDANCE COMPUTER - INSTALL FMS2 THALES	
			"S3" ASSOCIATED TO FG "I9": IAE ENGINES	
			A7-ADA	A7-ADB A7-CJA
			A7-ADC	A7-ADD A7-ADS
			A7-ADE	A7-ADF A7-ADT
			A7-ADG	A7-ADH A7-ADI
			A7-ADJ	A7-CJB MSN 3071

N 040B	35216	LANDING GEAR - NORMAL BRAKING -	
		INSTALL BSCU STD L4.8 (EM2)	
			MSN 3071	

. 040A	35218	EQUIPMENT/FURNISHINGS - CURTAINS AND	
		PARTITIONS - INSTALL PPTC FOR COCKPIT	
			DOOR STRIKE PROTECTION- BY SB ONLY	
			A7-ABR	A7-ADA A7-ADB
			A7-CJA	A7-ADC A7-ADD
			A7-ADS	A7-ADE A7-ADF
			A7-ADT	A7-ADG A7-ADH
			A7-ADI	A7-ADJ A7-CJB

N 040B	35219	EQUIPMENT/FURNISHINGS - CURTAINS AND	
		PARTITIONS - INSTALL IMPROVED STRIKES	
			FOR COCKPIT DOOR	
			MSN 3071	

N 040B	35220	INDICATING/RECORDING SYSTEMS -	
		FLIGHT WARNING COMPUTER (FWC) -	
			INSTALL FWC STANDARD H2F3	
			MSN 3071	

M

V	REV	MOD	MP	TITLE	VALIDITY
T		SB			

N	0408	35249	LANDING GEAR - STEERING - INSTALL NWS ELECTRICAL BOX WITH NEW MICRO-SWITCH AND IMPROVED SEALING	
				MSN 3071	

N	0408	35863	AIR CONDITIONING - PACK TEMPERATURE CONTROL - INSTALL AIR CONDITIONING CONTROLLER P/N 1803B0000-02	
				MSN 3071	

N	0408	35864	AIRBORNE AUXILIARY POWER - GENERAL - INSTALL APIC APS3200 APU AS STANDARD (REPLACES HONEYWELL GTCP36-300)	
				MSN 3071	

N	0408	36725	INDICATING/RECORDING SYSTEMS-ELECTRONIC INSTRUMENT SYSTEM(EIS)-INSTALL DISPLAY MANAGEMENT COMPUTER SOFTWARE EIS2 S7	
				MSN 3071	

.	040A	36734	FUEL - MAIN FUEL PUMP SYSTEM - APPLY	
		28-1152	01	CORRECT TORQUE SETTING + SCREW LOCKING	
		28-1153	01	ON GAS RETURN OUTLET FIXING BOLTS	
				ALL	